

Data sheet

Check valve

Types NRV and NRVH Version 2



NRV and NRVH piston type check valves are designed for installation in commercial refrigerating systems and in residential or industrial air conditioning plants. They are used to control the unidirectional flow of refrigerant so as to prevent backflow.

Features

- Ensure correct flow direction
- Available in both straightway and angleway versions
- Hermetic tight design for solder versions
- Built-in damping piston that makes the valves suitable for installation in lines where pulsation can occur, e.g. in the discharge line from the compressor
- NRVH type check valve is with stronger spring and it's recommended to use for compressors in parallel (i.e. power packs) where higher level of pulsation and vibration are expected
- Oversize connections provide flexibility in use

Data sheet | Check valve, types NRV and NR VH

Approvals



Technical data

Valve type	Connection type	Max. working pressure (PS/MWP)	Refrigerants
NRV/NRVH 6-19	Straight-way - flare	46 bar/ 667 psig	R134a, R22/R407C, R404A/R507, R407A, R407F, R407H, R410A, R448A, R449A, R449B, R450A, R452A, R513A, R515B, R1233zd(E), R1234ze(E)
NRV/NRVH 22s-28s	Angle-way - solder	46 bar/ 667 psig	R134a, R22/R407C, R290, R404A/R507, R407A, R407F, R407H, R410A, R448A, R449A, R449B, R450A, R452A, R452B, R454A, R454B, R454C, R455A, R513A, R515B, R516A, R600, R600a, R1233zd(E), R1234ze(E), R1234yf, R1270
NRV/NRVH 28s¹⁾-35s¹⁾	Angle-way - solder	46 bar/ 667 psig	R134a, R22/R407C, R404A/R507, R407A, R407F, R407H, R410A, R448A, R449A, R449B, R450A, R452A, R513A, R515B, R1233zd(E), R1234ze(E)
NRV/NRVH 6s-19s¹⁾	Straight-way - solder	49 bar / 710 psig	R134a, R22/R407C, R290, R32, R404A/R507, R407A, R407F, R407H, R410A, R448A, R449A, R449B, R450A, R452A, R452B, R454A, R454B, R454C, R455A, R513A, R515B, R516A, R600, R600a, R1233zd(E), R1234ze(E), R1234yf, R1270
NRV/NRVH 22s E-28s E	Angle-way - solder	49 bar / 710 psig	R290, R32, R452B, R454A, R454B, R454C, R455A, R516A, R600, R600a, R1234yf, R1270
NRV/NRVH 28s E¹⁾-35s E¹⁾	Angle-way - solder	49 bar / 710 psig	R32, R452B, R454A, R454B, R454C, R455A, R516A, R1234yf

¹⁾ Oversize connections

Refrigerant oil: POE, PAG (PVE, PAO)



Note:

- For complete list of approved refrigerants, go to <http://store.danfoss.com/> and search for individual code numbers, where refrigerants are listed as part of product details.
- This product is approved for R290, R32, R452B, R454A, R454B, R454C, R455A, R516A, R600, R600a, R1234yf and R1270 by ignition source assessment in accordance to standard EN13463-1.
- R1234ze can be used for NRV size up to 35s according to the PED category I, Fluid II
- NRV/NRVH is not suitable for oil line application. For detailed information please contact Danfoss.

Dimensioning and selection

When selecting the right Danfoss check valve the capacity tables should be utilised together with plant requirements concerning piping and connection sizes. The optimum solution should include the highest capacity at lowest pressure drop across the valve before it closes. Further, when dimensioning and selecting Danfoss check valves for mounting into the compressor discharge line, it is important to be aware of the following:

The differential pressure across the valve must always be higher than the given minimum pressure drop at which the valve is completely open. This also applies to lowest capacities for compressor with capacity regulation.

NRVH type check valve is with stronger spring and it's recommended to use for compressors in parallel (i.e. power packs) where higher level of pulsation and vibration are expected.

Design / Function

1. Copper tube
2. Solder ring
3. Washer
4. Teflon disk
5. Piston
6. Spring
7. Valve body
8. Guide
9. Stop face
10. Cover

Straightway solder version

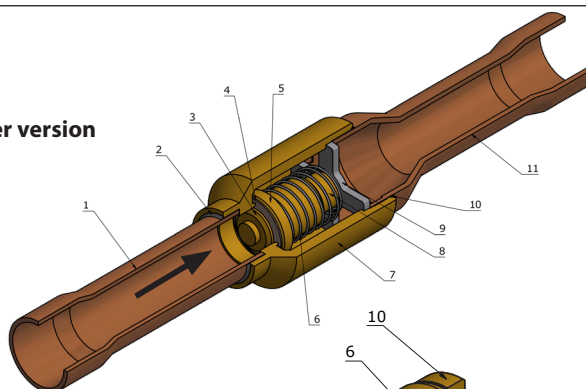

Angleway solder version

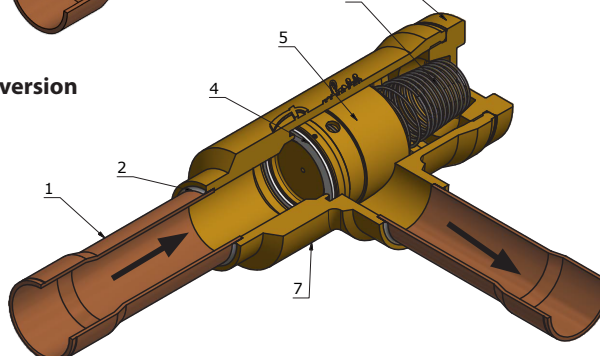

Data sheet | Check valve, types NRV and NRVH

Ordering



Straightway Flare Version without flare nut

Valve type	Connection		Min. OPD Δp ²⁾		K _v value ³⁾	C _v value ³⁾	Max. working pressure: PS/MWP	Media temperature range	For flammable refrigerant ⁴⁾	PED category	Code no. Multi pack ⁵⁾
	[in]	[mm]	[bar]	[psi]	[m ³ /h]	[gal/min]					
NRV 6	1/4	6	0.07	1.01	0.56	0.65	46 bar / 667 psig	-50 °C - 140 °C / -58 °F - 285 °F	No	Article 4, Paragraph 3	020-1040
NRV 10	3/8	10	0.07	1.01	1.2	1.39					020-1041
NRV 12	1/2	12	0.05	0.72	2.05	2.37					020-1042
NRV 16	5/8	16	0.05	0.72	3.6	4.16					020-1043
NRV 19	3/4	19	0.05	0.72	5.5	6.36					020-1044



Angleway Solder ODF Version, PS = 46 bar

Valve type	Connection		Min. OPD Δp ²⁾		K _v value ³⁾	C _v value ³⁾	Max. working pressure: PS/MWP	Media temperature range	For flammable refrigerant ⁴⁾	PED category	Code no. Multi pack ⁵⁾
	[in]	[mm]	[bar]	[psi]	[m ³ /h]	[gal/min]					
NRV 22s	7/8	22	0.04	0.58	8.5	9.83	46 bar / 667 psig	-50 °C - 140 °C / -58 °F - 285 °F	Yes	Article 4, Paragraph 3	020-1020
NRVH 22s	7/8	22	0.30	4.35	8.5	9.83					020-1032
NRV 22s ¹⁾	1 1/8	—	0.04	0.58	8.5	9.83					020-1060
	—	28	0.04	0.58	8.5	9.83					020-1055
NRVH 22s ¹⁾	1 1/8	—	0.30	4.35	8.5	9.83					020-1072
	—	28	0.30	4.35	8.5	9.83					020-1067
NRV 28s	1 1/8	—	0.04	0.58	16.5	19.07					020-1021
	—	28	0.04	0.58	16.5	19.07					020-1025
NRVH 28s	1 1/8	—	0.30	4.35	16.5	19.07					020-1029
	—	28	0.30	4.35	16.5	19.07					020-1033
NRV 28s ¹⁾	1 3/8	35	0.04	0.58	16.5	19.07			020-1056		
NRVH 28s ¹⁾	1 3/8	35	0.30	4.35	16.5	19.07			020-1068		
NRV 35s	1 3/8	35	0.04	0.58	29	33.52			020-1026		
NRVH 35s	1 3/8	35	0.30	4.35	29	33.52			020-1034		
NRV 35s ¹⁾	1 5/8	—	0.04	0.58	29	33.52			020-1061		
	—	42	0.04	0.58	29	33.52			020-1027		
NRVH 35s ¹⁾	1 5/8	—	0.30	4.35	29	33.52			020-1073		
	—	42	0.30	4.35	29	33.52			020-1035		

Angleway Solder ODF Version, PS = 49 bar ⁶⁾

Valve type	Connection		Min. OPD Δp ²⁾		K _v value ³⁾	C _v value ³⁾	Max. working pressure: PS/MWP	Media temperature range	For flammable refrigerant ⁴⁾	PED category	Code no. Multi pack
	[in]	[mm]	[bar]	[psi]	[m ³ /h]	[gal/min]					
NRV 22s E	7/8	22	0.04	0.58	8.5	9.83	49 bar / 710 psig	-50 °C - 155 °C / -58 °F - 311 °F	Yes	Article 4, Paragraph 3	020-3020
NRVH 22s E	7/8	22	0.30	4.35	8.5	9.83					020-3032
NRV 22s E ¹⁾	1 1/8	—	0.04	0.58	8.5	9.83					020-3060
	—	28	0.04	0.58	8.5	9.83					020-3055
NRVH 22s E ¹⁾	1 1/8	—	0.30	4.35	8.5	9.83					020-3072
	—	28	0.30	4.35	8.5	9.83					020-3067
NRV 28s E	1 1/8	—	0.04	0.58	16.5	19.07					020-3021
	—	28	0.04	0.58	16.5	19.07					020-3025
NRVH 28s E	1 1/8	—	0.30	4.35	16.5	19.07					020-3029
	—	28	0.30	4.35	16.5	19.07					020-3039
NRV 28s E ¹⁾	1 3/8	35	0.04	0.58	16.5	19.07			020-3056		
NRVH 28s E ¹⁾	1 3/8	35	0.30	4.35	16.5	19.07			020-3068		
NRV 35s E	1 3/8	35	0.04	0.58	29	33.52			020-3026		
NRVH 35s E	1 3/8	35	0.30	4.35	29	33.52			020-3036		
NRV 35s E ¹⁾	1 5/8	—	0.04	0.58	29	33.52			020-3061		
	—	42	0.04	0.58	29	33.52			020-3027		
NRVH 35s E ¹⁾	1 5/8	—	0.30	4.35	29	33.52			020-3073		
	—	42	0.30	4.35	29	33.52			020-3035		

¹⁾ Oversize connections

²⁾ Δp = Minimum Opening Pressure Differential

³⁾ The K_v / C_v value is the flow of water in [m³/h – gal/min] at a pressure drop across valve of 1 bar/14.5 psig
 $\rho = 1000 \text{ kg/m}^3 - 2205 \text{ lbs/G}$

⁴⁾ Please refer to the Danfoss refrigerant list for flammable refrigerants, for other flammable refrigerants please contact Danfoss.

⁵⁾ For the code selection of Industrial pack version please contact Danfoss.

⁶⁾ The 49bar NRV angleway version can be only used with flammable refrigerants.

The 49bar NRV angleway version which belong to PED category II can be only used with R32, R452B, R454A, R454B, R454C, R455A, R516A, R1234yf.

Data sheet | Check valve, types NRV and NRVH

Ordering (continued)



Straightway Solder ODF Version

Valve type	Connection		Min. OPD Δp ²⁾		K _v value ³⁾	C _v value ³⁾	Max. working pressure: PS/MWP	Media temperature range	For flammable refrigerant ⁴⁾	PED category	Code no. Multi pack ⁵⁾
	[in]	[mm]	[bar]	[psi]	[m ³ /h]	[gal/min]					
NRV 6s v2	1/4	—	0.04	0.58	0.67	0.77	49 bar / 710 psig	-50 °C - 155 °C / -58 °F - 311 °F	Yes	Article 4, Paragraph 3	020B1010
	—	6	0.04	0.58	0.67	0.77					020B1014
NRV 6s v2 ¹⁾	3/8	—	0.04	0.58	0.67	0.77					020B1057
	—	10	0.04	0.58	0.67	0.77					020B1050
NRVH 6s v2 ¹⁾	3/8	—	0.20	2.90	0.67	0.77					020B1069
	—	10	0.20	2.90	0.67	0.77					020B1062
NRV 10s v2	3/8	—	0.04	0.58	1.64	1.90					020B1011
	—	10	0.04	0.58	1.64	1.90					020B1015
NRVH 10s v2	3/8	—	0.20	2.90	1.64	1.90					020B1046
	—	10	0.20	2.90	1.64	1.90					020B1036
NRV 10s v2 ¹⁾	1/2	—	0.04	0.58	1.64	1.90					020B1058
	—	12	0.04	0.58	1.64	1.90					020B1051
NRVH 10s v2 ¹⁾	1/2	—	0.20	2.90	1.64	1.90					020B1070
	—	12	0.20	2.90	1.64	1.90					020B1063
NRV 12s v2	1/2	—	0.02	0.29	2.50	2.89					020B1012
	—	12	0.02	0.29	2.50	2.89					020B1016
NRVH 12s v2	1/2	—	0.20	2.90	2.50	2.89					020B1039
	—	12	0.20	2.90	2.50	2.89					020B1037
NRV 12s v2 ¹⁾	5/8	16	0.02	0.29	2.50	2.89					020B1052
NRVH 12s v2 ¹⁾	5/8	16	0.20	2.90	2.50	2.89					020B1064
NRV 16s v2	5/8	16	0.02	0.29	4.00	4.62					020B1018
NRVH 16s v2	5/8	16	0.20	2.90	4.00	4.62					020B1038
NRV 16s v2 ¹⁾	—	18	0.02	0.29	4.00	4.62					020B1053
NRVH 16s v2 ¹⁾	—	18	0.20	2.90	4.00	4.62					020B1065
NRV 16s v2 ¹⁾	3/4	19	0.02	0.29	4.00	4.62					020B1059
NRVH 16s v2 ¹⁾	3/4	19	0.20	2.90	4.00	4.62					020B1071
NRV 19s v2	—	18	0.02	0.29	6.50	7.51					020B1017
NRVH 19s v2	—	18	0.14	2.03	6.50	7.51					020B1008
NRV 19s v2	3/4	19	0.02	0.29	6.50	7.51					020B1019
NRVH 19s v2	3/4	19	0.14	2.03	6.50	7.51					020B1023
NRV 19s v2 ¹⁾	7/8	22	0.02	0.29	6.50	7.51	020B1054				
NRVH 19s v2 ¹⁾	7/8	22	0.14	2.03	6.50	7.51	020B1066				

¹⁾ Oversize connections

²⁾ Δp = Minimum Opening Pressure Differential

³⁾ The K_v, C_v value is the flow of water in [m³/h – gal/min] at a pressure drop across valve of 1 bar/14.5 psig
 $\rho = 1000 \text{ kg/m}^3 - 2205 \text{ lbs/G}$

⁴⁾ Please refer to the Danfoss refrigerant list for flammable refrigerants, for other flammable refrigerants please contact Danfoss

⁵⁾ For the code selection of Industrial pack version please contact Danfoss.

Data sheet | Check valve, types NRV and NRHV

SI units

Capacity

Liquid capacity (kW)

Type	Liquid capacity ¹⁾ at pressure drop across valve Δp [bar]			
	NRV			
	0.05	0.07	0.14	0.2

R134a				
NRV 6 v2	1.4	4.6	11.0	14.4
NRV 10 v2	8.3	18.2	29.5	35.2
NRV 12 v2	26.9	31.8	44.9	53.7
NRV 16 v2	38.8	50.8	71.9	85.9
NRV 19 v2	69.8	82.6	116.9	139.7
NRV 22	91.6	108.4	153.3	183.3
NRV 28	177.9	210.5	297.7	355.8
NRV 35	312.7	369.9	523.2	625.3

R22				
NRV 6 v2	1.5	4.9	11.8	15.5
NRV 10 v2	9.0	19.7	31.8	38.0
NRV 12 v2	28.9	34.2	48.4	57.9
NRV 16 v2	41.8	54.8	77.5	92.6
NRV 19 v2	75.2	89.0	125.9	150.5
NRV 22	98.4	116.4	164.6	196.8
NRV 28	191.0	226.0	319.6	382.0
NRV 35	335.7	397.2	561.7	671.4

R404A				
NRV 6 v2	1.0	3.4	8.0	10.5
NRV 10 v2	6.1	13.4	21.6	25.8
NRV 12 v2	19.7	23.3	32.9	39.3
NRV 16 v2	28.4	37.2	52.6	62.9
NRV 19 v2	51.1	60.5	85.5	102.2
NRV 22	67.0	79.3	112.2	134.1
NRV 28	130.1	154.0	217.8	260.3
NRV 35	228.7	270.6	382.7	457.5

R410A				
NRV 6 v2	1.5	4.9	11.6	15.3
NRV 10 v2	8.8	19.3	31.2	37.3
NRV 12 v2	28.5	33.7	47.6	56.9
NRV 16 v2	41.1	53.9	76.2	91.1
NRV 19 v2	74.0	87.6	123.8	148.0
NRV 22	96.7	114.4	161.8	193.4
NRV 28	187.7	222.1	314.1	375.4
NRV 35	329.9	390.3	552.0	659.7

Suction vapour capacity in [kW]

Pressure drop across valve Δp [bar]	Suction vapour capacity ¹⁾ at evaporating temperature t _e [°C]			
	NRV			
	-30	-10	0	5

R134a				
0.07	0.22	0.39	0.50	0.56
0.07	0.91	1.59	2.01	2.24
0.07	1.68	2.83	3.55	3.95
0.07	2.68	4.53	5.68	6.32
0.07	4.36	7.37	9.24	10.27
0.07	5.73	9.67	12.11	13.47
0.07	11.13	18.77	23.51	26.14
0.07	19.56	32.99	41.33	45.94

R22				
0.07	0.34	0.54	0.66	0.72
0.07	1.39	2.18	2.64	2.89
0.07	2.50	3.84	4.64	5.07
0.07	3.99	6.14	7.42	8.11
0.07	6.49	9.98	12.05	13.17
0.07	8.48	13.05	15.76	17.23
0.07	16.47	25.33	30.59	33.44
0.07	28.94	44.52	53.77	58.78

R404A				
0.07	0.29	0.47	0.59	0.65
0.07	1.17	1.90	2.35	2.59
0.07	2.09	3.34	4.12	4.54
0.07	3.34	5.35	6.59	7.27
0.07	5.43	8.70	10.71	11.81
0.07	7.09	11.37	14.01	15.46
0.07	13.77	22.07	27.19	30.02
0.07	24.20	38.79	47.79	52.76

R410A				
0.07	0.44	0.68	0.83	0.90
0.07	1.78	2.74	3.30	3.61
0.07	3.16	4.80	5.78	6.32
0.07	5.05	7.69	9.26	10.11
0.07	8.21	12.49	15.04	16.42
0.07	10.72	16.35	19.70	21.52
0.07	20.81	31.73	38.24	41.77
0.07	36.57	55.77	67.21	73.42

Hot gas capacity in [kW]

Hot gas capacity ¹⁾ at pressure drop across valve Δp [bar]	NRV			
	0.05	0.07	0.14	0.2

R134a				
0.2	0.7	1.7	2.2	
1.3	2.8	4.5	5.4	
4.2	4.9	6.9	8.2	
6.0	7.9	11.1	13.2	
10.8	12.8	18.0	21.4	
14.2	16.8	23.6	28.1	
27.6	32.6	45.9	54.6	
48.6	57.4	80.7	95.9	

R22				
0.3	0.9	2.1	2.8	
1.6	3.5	5.7	6.8	
5.2	6.2	8.7	10.4	
7.5	9.9	14.0	16.6	
13.6	16.1	22.7	27.0	
17.8	21.0	29.6	35.3	
34.5	40.8	57.5	68.6	
60.7	71.8	101.1	120.5	

R404A				
0.2	0.8	1.8	2.4	
1.4	3.1	4.9	5.9	
4.5	5.3	7.5	9.0	
6.5	8.5	12.0	14.3	
11.7	13.9	19.6	23.3	
15.4	18.2	25.6	30.6	
29.9	35.3	49.8	59.3	
52.5	62.0	87.4	104.2	

R410A				
0.3	1.1	2.6	3.4	
2.0	4.4	7.0	8.4	
6.4	7.6	10.7	12.8	
9.3	12.2	17.2	20.5	
16.7	19.8	27.9	33.3	
21.9	25.9	36.5	43.6	
42.5	50.2	70.9	84.6	
74.7	88.3	124.6	148.6	

Hot gas capacity in [kW]

Type	Hot gas capacity ¹⁾ at pressure drop across valve Δp [bar]			
	NRVH			
	0.2	0.25	0.3	0.35

R134a				
NRVH 6 v2	0.1	0.3	1.4	2.0
NRVH 10 v2	0.0	2.9	5.0	6.5
NRVH 12 v2	5.6	9.2	10.0	10.8
NRVH 16 v2	1.9	10.5	13.8	15.9
NRVH 19 v2	16.0	23.8	26.0	28.0
NRVH 22	-	-	34.1	36.7
NRVH 28	-	-	66.3	71.3
NRVH 35	-	-	116.5	125.3

R22				
NRVH 6 v2	0.1	0.4	1.8	2.6
NRVH 10 v2	0.0	3.6	6.3	8.2
NRVH 12 v2	7.0	11.6	12.7	13.6
NRVH 16 v2	2.5	13.4	17.6	20.2
NRVH 19 v2	20.2	30.1	32.9	35.5
NRVH 22	-	-	43.0	46.4
NRVH 28	-	-	83.5	90.0
NRVH 35	-	-	146.8	158.2

R404A				
NRVH 6 v2	0.1	0.4	1.6	2.3
NRVH 10 v2	0.0	3.1	5.4	7.1
NRVH 12 v2	6.1	10.0	10.9	11.8
NRVH 16 v2	2.1	11.6	15.2	17.5
NRVH 19 v2	17.5	26.0	28.4	30.6
NRVH 22	-	-	37.2	40.1
NRVH 28	-	-	72.3	77.9
NRVH 35	-	-	127.1	137.0

R410A				
NRVH 6 v2	0.2	0.5	2.3	3.2
NRVH 10 v2	0.0	4.5	7.8	10.1
NRVH 12 v2	8.7	14.3	15.6	16.8
NRVH 16 v2	3.1	16.6	21.8	25.1
NRVH 19 v2	25.0	37.1	40.6	43.8
NRVH 22	-	-	53.2	57.3
NRVH 28	-	-	103.2	111.3
NRVH 35	-	-	181.4	195.7

1) Rated capacities are based on:
 -Evaporating temperature, t_e = -10 °C.
 -Condensing temperature, t_c = 30 °C.
 -Subcooling t_{sub} = 5 K.
 -Delta superheat t_{sh} = 0 K.
 -Discharge temperature, t_d = 80 °C ahead of the valve.
 The table values refer to the evaporator capacity.

Correction factors

When selecting the evaporator capacity is to be multiplied by a correction factor depending on the liquid temperature t_l ahead of the valve/the evaporator. The corrected capacity can then be found from the table.

System capacity = Correction factor × Table capacity

Correction factors for liquid temperature t_l

t _l [°C]	-10	0	10	15	20	25	30	35	40	45	50
R134a	0.73	0.79	0.86	0.90	0.95	1.00	1.06	1.12	1.19	1.27	1.37
R22	0.76	0.82	0.88	0.92	0.96	1.00	1.05	1.10	1.16	1.22	1.30
R404A	0.67	0.74	0.82	0.87	0.93	1.00	1.08	1.17	1.29	1.43	1.61
R410A	0.72	0.78	0.85	0.90	0.94	1.00	1.06	1.14	1.22	1.33	1.46

Data sheet | Check valve, types NRV and NRVH

Capacity

SI units

Liquid capacity [kW]

Type	Liquid capacity ¹⁾ at pressure drop across valve Δp [bar]			
	NRV			
	0.05	0.07	0.14	0.2

R407A				
NRV 6 v2	1.4	4.4	10.5	13.8
NRV 10 v2	7.9	17.4	28.2	33.7
NRV 12 v2	25.7	30.4	42.9	51.3
NRV 16 v2	37.0	48.6	68.7	82.1
NRV 19 v2	66.7	78.9	111.6	133.4
NRV 22	87.5	103.5	146.4	175.0
NRV 28	169.9	201.0	284.2	339.7
NRV 35	298.5	353.2	499.5	597.1

Suction vapour capacity in [kW]

Pressure drop across valve Δp [bar]	Suction vapour capacity ¹⁾ at evaporating temperature t _e [°C]			
	NRV			
	-30	-10	0	5

R407A				
0.07	0.30	0.50	0.62	0.68
0.07	1.21	2.00	2.47	2.74
0.07	2.17	3.52	4.35	4.80
0.07	3.48	5.63	6.95	7.68
0.07	5.65	9.15	11.30	12.48
0.07	7.40	12.00	14.82	16.38
0.07	14.37	23.29	28.77	31.79
0.07	25.25	40.94	50.57	55.87

Hot gas capacity in [kW]

Type	Hot gas capacity ¹⁾ at pressure drop across valve Δp [bar]			
	NRV			
	0.05	0.07	0.14	0.2

R407A				
0.3	0.9	2.2	2.9	
1.7	3.6	5.9	7.0	
5.4	6.3	8.9	10.6	
7.7	10.1	14.3	17.0	
13.9	16.5	23.2	27.7	
18.3	21.6	30.5	36.4	
35.5	42.0	59.2	70.6	
62.5	73.9	104.1	124.1	

Hot gas capacity in [kW]

Type	Hot gas capacity ¹⁾ at pressure drop across valve Δp [bar]			
	NRVH			
	0.2	0.25	0.3	0.35

RR407A				
NRVH 6 v2	0.2	0.4	1.9	2.7
NRVH 10 v2	0.0	3.7	6.5	8.4
NRVH 12 v2	7.2	11.9	13.0	14.0
NRVH 16 v2	2.5	13.7	18.1	20.8
NRVH 19 v2	20.8	30.9	33.8	36.4
NRVH 22	-	-	44.4	47.8
NRVH 28	-	-	86.1	92.8
NRVH 35	-	-	151.3	163.1

R407C				
NRV 6 v2	1.5	4.7	11.3	14.8
NRV 10 v2	8.6	18.8	30.4	36.3
NRV 12 v2	27.7	32.8	46.3	55.4
NRV 16 v2	40.0	52.4	74.1	88.6
NRV 19 v2	72.0	85.2	120.5	144.0
NRV 22	94.4	111.7	157.9	188.8
NRV 28	183.2	216.8	306.6	366.5
NRV 35	322.0	381.0	538.9	644.1

R407C				
0.07	0.30	0.50	0.62	0.69
0.07	1.22	2.02	2.50	2.77
0.07	2.20	3.56	4.40	4.86
0.07	3.52	5.70	7.04	7.77
0.07	5.72	9.27	11.44	12.63
0.07	7.48	12.14	14.99	16.56
0.07	14.52	23.56	29.10	32.14
0.07	25.52	41.41	51.14	56.49

R407C				
0.3	0.9	2.2	2.9	
1.7	3.7	6.0	7.2	
5.5	6.5	9.2	11.0	
8.0	10.5	14.7	17.6	
14.4	17.0	23.9	28.5	
18.9	22.3	31.4	37.4	
36.6	43.3	61.0	72.7	
64.3	76.0	107.2	127.8	

R407C				
NRVH 6 v2	0.2	0.5	1.9	2.8
NRVH 10 v2	0.0	3.8	6.7	8.7
NRVH 12 v2	7.4	12.2	13.4	14.4
NRVH 16 v2	2.6	14.1	18.6	21.4
NRVH 19 v2	21.4	31.8	34.8	37.5
NRVH 22	-	-	45.6	49.2
NRVH 28	-	-	88.6	95.5
NRVH 35	-	-	155.7	167.8

R407F				
NRV 6 v2	1.5	4.8	11.5	15.1
NRV 10 v2	8.7	19.2	31.0	37.0
NRV 12 v2	28.2	33.4	47.2	56.4
NRV 16 v2	40.7	53.4	75.5	90.2
NRV 19 v2	73.3	86.8	122.7	146.6
NRV 22	95.9	113.4	160.4	191.8
NRV 28	186.1	220.2	311.4	372.2
NRV 35	327.1	387.1	547.4	654.3

R407F				
0.07	0.33	0.54	0.67	0.74
0.07	1.34	2.18	2.68	2.96
0.07	2.39	3.83	4.71	5.19
0.07	3.83	6.14	7.54	8.31
0.07	6.22	9.97	12.25	13.50
0.07	8.14	13.04	16.02	17.66
0.07	15.80	25.31	31.10	34.27
0.07	27.77	44.48	54.66	60.24

R407F				
0.3	1.0	2.4	3.1	
1.8	3.9	6.4	7.6	
5.8	6.9	9.7	11.6	
8.4	11.0	15.6	18.6	
15.2	17.9	25.3	30.2	
19.8	23.5	33.1	39.4	
38.5	45.5	64.2	76.6	
67.7	80.0	112.9	134.6	

R407F				
NRVH 6 v2	0.2	0.5	2.0	2.9
NRVH 10 v2	0.0	4.1	7.0	9.2
NRVH 12 v2	7.9	12.9	14.1	15.2
NRVH 16 v2	2.8	15.0	19.7	22.7
NRVH 19 v2	22.6	33.6	36.8	39.6
NRVH 22	-	-	48.1	51.9
NRVH 28	-	-	93.4	100.7
NRVH 35	-	-	164.1	176.9

R407H				
NRV 6 v2	1.6	5.1	12.3	16.2
NRV 10 v2	9.3	20.5	33.1	39.6
NRV 12 v2	30.2	35.7	50.5	60.3
NRV 16 v2	43.5	57.1	80.7	96.5
NRV 19 v2	78.4	92.8	131.2	156.8
NRV 22	102.5	121.3	171.6	205.1
NRV 28	199.0	235.5	333.1	398.1
NRV 35	349.8	413.9	585.4	699.7

R407H				
0.07	0.33	0.54	0.67	0.74
0.07	1.33	2.18	2.69	2.97
0.07	2.39	3.85	4.73	5.21
0.07	3.83	6.15	7.56	8.34
0.07	6.23	10.00	12.29	13.55
0.07	8.14	13.07	16.07	17.71
0.07	15.80	25.38	31.20	34.39
0.07	27.78	44.60	54.83	60.44

R407H				
0.3	1.0	2.4	3.2	
1.8	4.0	6.5	7.8	
6.0	7.0	9.9	11.8	
8.6	11.3	15.9	18.9	
15.5	18.3	25.8	30.8	
20.3	24.0	33.8	40.3	
39.3	46.5	65.6	78.2	
69.1	81.7	115.2	137.4	

R407H				
NRVH 6 v2	0.2	0.5	2.1	3.0
NRVH 10 v2	0.0	4.2	7.2	9.4
NRVH 12 v2	8.0	13.2	14.4	15.6
NRVH 16 v2	2.8	15.3	20.1	23.1
NRVH 19 v2	23.1	34.3	37.5	40.5
NRVH 22	-	-	49.1	52.9
NRVH 28	-	-	95.3	102.7
NRVH 35	-	-	167.5	180.5

1) Rated capacities are based on:
 -Evaporating temperature, t_e = -10 °C.
 -Condensing temperature, t_c = 30 °C.
 -Subcooling t_{sub} = 5 K.
 -Delta superheat t_{sh} = 0 K.
 -Discharge temperature, t_d = 80 °C ahead of the valve.
 The table values refer to the evaporator capacity.

Correction factors

When selecting the evaporator capacity is to be multiplied by a correction factor depending on the liquid temperature t_l ahead of the valve/the evaporator. The corrected capacity can then be found from the table.

System capacity = Correction factor × Table capacity

Correction factors for liquid temperature t_l

t _l [°C]	-10	0	10	15	20	25	30	35	40	45	50
R407A	0.71	0.78	0.85	0.90	0.94	1.00	1.06	1.13	1.22	1.32	1.44
R407C	0.73	0.79	0.86	0.90	0.95	1.00	1.06	1.13	1.20	1.29	1.40
R407F	0.73	0.79	0.86	0.90	0.95	1.00	1.06	1.13	1.20	1.30	1.40
R407H	0.74	0.80	0.87	0.91	0.95	1.00	1.06	1.12	1.19	1.27	1.37

Data sheet | Check valve, types NRV and NRHV

SI units

Capacity

Liquid capacity (kW)

Type	Liquid capacity ¹⁾ at pressure drop across valve Δp [bar]			
	NRV			
	0.05	0.07	0.14	0.2

R448A				
NRV 6 v2	1.4	4.4	10.6	13.8
NRV 10 v2	8.0	17.5	28.3	33.8
NRV 12 v2	25.8	30.5	43.2	51.6
NRV 16 v2	37.2	48.8	69.1	82.5
NRV 19 v2	67.1	79.4	112.2	134.1
NRV 22	87.7	103.8	146.7	175.4
NRV 28	170.2	201.4	284.9	340.5
NRV 35	299.2	354.0	500.7	598.4

R449A				
NRV 6 v2	1.3	4.3	10.4	13.7
NRV 10 v2	7.9	17.3	28.0	33.4
NRV 12 v2	25.5	30.1	42.6	51.0
NRV 16 v2	36.8	48.2	68.2	81.5
NRV 19 v2	66.3	78.4	110.9	132.5
NRV 22	86.6	102.5	145.0	173.3
NRV 28	168.2	199.0	281.4	336.4
NRV 35	295.6	349.7	494.6	591.2

R449B				
NRV 6 v2	1.4	4.4	10.6	13.8
NRV 10 v2	8.0	17.6	28.4	33.9
NRV 12 v2	25.8	30.6	43.2	51.7
NRV 16 v2	37.3	48.9	69.2	82.7
NRV 19 v2	67.2	79.5	112.4	134.3
NRV 22	87.8	103.9	147.0	175.7
NRV 28	170.5	201.7	285.3	341.0
NRV 35	299.7	354.6	501.5	599.4

R450A				
NRV 6 v2	1.3	4.3	10.2	13.4
NRV 10 v2	7.7	16.9	27.3	32.7
NRV 12 v2	24.9	29.5	41.7	49.8
NRV 16 v2	35.9	47.2	66.7	79.7
NRV 19 v2	64.8	76.6	108.4	129.5
NRV 22	84.8	100.3	141.9	169.6
NRV 28	164.6	194.8	275.5	329.2
NRV 35	289.3	342.3	484.2	578.7

Suction vapour capacity in [kW]

Pressure drop across valve Δp [bar]	Suction vapour capacity ¹⁾ at evaporating temperature t _e [°C]			
	NRV			
	-30	-10	0	5

R448A				
0.07	0.31	0.51	0.63	0.70
0.07	1.26	2.05	2.53	2.79
0.07	2.25	3.61	4.44	4.90
0.07	3.60	5.78	7.11	7.84
0.07	5.86	9.39	11.55	12.73
0.07	7.66	12.30	15.14	16.70
0.07	14.87	23.88	29.39	32.42
0.07	26.13	41.97	51.66	56.98

R449A				
0.07	0.31	0.51	0.63	0.69
0.07	1.25	2.04	2.52	2.78
0.07	2.24	3.59	4.42	4.88
0.07	3.58	5.75	7.08	7.80
0.07	5.82	9.34	11.50	12.68
0.07	7.61	12.22	15.04	16.59
0.07	14.77	23.71	29.19	32.20
0.07	25.95	41.68	51.30	56.59

R449B				
0.07	0.31	0.51	0.63	0.70
0.07	1.26	2.06	2.54	2.80
0.07	2.26	3.63	4.46	4.92
0.07	3.62	5.80	7.14	7.87
0.07	5.88	9.43	11.60	12.80
0.07	7.68	12.33	15.17	16.73
0.07	14.92	23.94	29.45	32.48
0.07	26.22	42.07	51.76	57.09

R450A				
0.07	0.19	0.35	0.45	0.50
0.07	0.79	1.42	1.80	2.02
0.07	1.48	2.54	3.20	3.57
0.07	2.36	4.06	5.12	5.71
0.07	3.84	6.60	8.32	9.28
0.07	5.01	8.62	10.89	12.14
0.07	9.72	16.74	21.13	23.57
0.07	17.09	29.42	37.14	41.43

Hot gas capacity in [kW]

Hot gas capacity ¹⁾ at pressure drop across valve Δp [bar]	NRV			
	NRV			
	0.05	0.07	0.14	0.2

R448A				
0.3	0.9	2.2	2.9	
1.7	3.7	6.0	7.1	
5.5	6.5	9.1	10.9	
7.9	10.3	14.6	17.4	
14.2	16.8	23.7	28.2	
18.6	22.0	31.1	37.0	
36.2	42.8	60.3	71.9	
63.6	75.1	106.0	126.3	

R449A				
0.3	0.9	2.2	2.9	
1.7	3.7	5.9	7.0	
5.4	6.4	9.0	10.7	
7.8	10.2	14.4	17.2	
14.0	16.6	23.4	27.9	
18.4	21.7	30.6	36.5	
35.6	42.1	59.4	70.8	
62.7	74.1	104.4	124.5	

R449B				
0.3	0.9	2.2	2.9	
1.7	3.7	6.0	7.1	
5.5	6.5	9.1	10.8	
7.9	10.3	14.6	17.3	
14.2	16.8	23.6	28.2	
18.6	21.9	30.9	36.9	
36.0	42.6	60.0	71.6	
63.3	74.8	105.5	125.8	

R450A				
0.2	0.6	1.5	2.0	
1.2	2.6	4.1	4.9	
3.8	4.5	6.3	7.5	
5.5	7.2	10.1	12.0	
9.9	11.7	16.4	19.5	
12.9	15.3	21.5	25.5	
25.1	29.6	41.6	49.5	
44.1	52.1	73.2	87.0	

Hot gas capacity in [kW]

Type	Hot gas capacity ¹⁾ at pressure drop across valve Δp [bar]			
	NRVH			
	0.2	0.25	0.3	0.35

R448A				
NRVH 6 v2	0.2	0.4	1.9	2.7
NRVH 10 v2	0.0	3.8	6.6	8.6
NRVH 12 v2	7.4	12.1	13.2	14.3
NRVH 16 v2	2.6	14.0	18.4	21.2
NRVH 19 v2	21.2	31.5	34.4	37.1
NRVH 22	-	-	45.1	48.7
NRVH 28	-	-	87.6	94.5
NRVH 35	-	-	154.0	166.0

R449A				
NRVH 6 v2	0.2	0.4	1.9	2.7
NRVH 10 v2	0.0	3.8	6.5	8.5
NRVH 12 v2	7.3	12.0	13.1	14.1
NRVH 16 v2	2.6	13.8	18.2	20.9
NRVH 19 v2	20.9	31.1	34.0	36.7
NRVH 22	-	-	44.5	47.9
NRVH 28	-	-	86.4	93.1
NRVH 35	-	-	151.8	163.6

R449B				
NRVH 6 v2	0.2	0.4	1.9	2.7
NRVH 10 v2	0.0	3.8	6.6	8.6
NRVH 12 v2	7.3	12.1	13.2	14.2
NRVH 16 v2	2.6	14.0	18.4	21.2
NRVH 19 v2	21.1	31.4	34.4	37.0
NRVH 22	-	-	45.0	48.4
NRVH 28	-	-	87.3	94.0
NRVH 35	-	-	153.4	165.3

R450A				
NRVH 6 v2	0.1	0.3	1.3	1.8
NRVH 10 v2	0.0	2.6	4.5	5.9
NRVH 12 v2	5.1	8.3	9.1	9.8
NRVH 16 v2	1.8	9.5	12.5	14.4
NRVH 19 v2	14.6	21.7	23.6	25.4
NRVH 22	-	-	30.9	33.2
NRVH 28	-	-	60.0	64.5
NRVH 35	-	-	105.5	113.4

1) Rated capacities are based on:
 -Evaporating temperature, t_e = -10 °C.
 -Condensing temperature, t_c = 30 °C.
 -Subcooling t_{sub} = 5 K.
 -Delta superheat t_{sh} = 0 K.
 -Discharge temperature, t_d = 80 °C ahead of the valve.
 The table values refer to the evaporator capacity.

Correction factors

When selecting the evaporator capacity is to be multiplied by a correction factor depending on the liquid temperature t_l ahead of the valve/the evaporator. The corrected capacity can then be found from the table.

System capacity = Correction factor × Table capacity

Correction factors for liquid temperature t_l

t _l [°C]	-10	0	10	15	20	25	30	35	40	45	50
R448A	0.71	0.78	0.85	0.90	0.94	1.00	1.06	1.13	1.22	1.32	1.44
R449A	0.71	0.77	0.85	0.89	0.94	1.00	1.06	1.14	1.22	1.32	1.44
R449B	0.71	0.78	0.85	0.90	0.94	1.00	1.06	1.13	1.22	1.32	1.44
R450A	0.72	0.79	0.86	0.90	0.95	1.00	1.06	1.12	1.20	1.28	1.38

Data sheet | Check valve, types NRV and NR VH

SI units

Capacity

Liquid capacity (kW)

Type	Liquid capacity ¹⁾ at pressure drop across valve Δp [bar]			
	NRV			
	0.05	0.07	0.14	0.2

R452A				
NRV 6 v2	1.1	3.4	8.2	10.7
NRV 10 v2	6.2	13.6	21.9	26.2
NRV 12 v2	20.0	23.6	33.4	40.0
NRV 16 v2	28.8	37.8	53.5	63.9
NRV 19 v2	51.9	61.5	86.9	103.9
NRV 22	67.7	80.1	113.3	135.4
NRV 28	131.4	155.5	219.9	262.8
NRV 35	230.9	273.3	386.4	461.9

Suction vapour capacity in [kW]

Pressure drop across valve Δp [bar]	Suction vapour capacity ¹⁾ at evaporating temperature t _e [°C]			
	NRV			
	-30	-10	0	5

R452A				
0.07	0.27	0.45	0.56	0.62
0.07	1.11	1.82	2.26	2.50
0.07	1.98	3.20	3.96	4.38
0.07	3.17	5.13	6.34	7.01
0.07	5.14	8.33	10.30	11.40
0.07	6.70	10.87	13.45	14.88
0.07	13.01	21.10	26.11	28.89
0.07	22.87	37.08	45.89	50.77

Hot gas capacity in [kW]

Type	Hot gas capacity ¹⁾ at pressure drop across valve Δp [bar]			
	NRV			
	0.05	0.07	0.14	0.2

R452A				
0.2	0.8	1.9	2.5	
1.4	3.1	5.1	6.0	
4.6	5.5	7.7	9.2	
6.7	8.8	12.4	14.7	
12.1	14.3	20.1	24.0	
15.7	18.6	26.2	31.3	
30.5	36.1	50.9	60.7	
53.7	63.5	89.5	106.7	

Hot gas capacity in [kW]

Type	Hot gas capacity ¹⁾ at pressure drop across valve Δp [bar]			
	NRVH			
	0.2	0.25	0.3	0.35

R452A				
NRVH 6 v2	0.1	0.4	1.6	2.3
NRVH 10 v2	0.0	3.2	5.6	7.3
NRVH 12 v2	6.2	10.3	11.2	12.1
NRVH 16 v2	2.2	11.9	15.6	18.0
NRVH 19 v2	18.0	26.7	29.2	31.5
NRVH 22	-	-	38.1	41.1
NRVH 28	-	-	74.0	79.8
NRVH 35	-	-	130.1	140.2

R513A

NRV 6 v2	1.3	4.1	9.8	12.8
NRV 10 v2	7.4	16.2	26.2	31.4
NRV 12 v2	23.9	28.3	40.0	47.8
NRV 16 v2	34.5	45.3	64.0	76.5
NRV 19 v2	62.2	73.6	104.0	124.3
NRV 22	76.2	90.2	127.5	152.4
NRV 28	147.9	175.1	247.6	295.9
NRV 35	260.0	307.7	435.1	520.1

R513A

0.07	0.21	0.38	0.48	0.54
0.07	0.89	1.54	1.94	2.17
0.07	1.62	2.74	3.43	3.82
0.07	2.60	4.38	5.49	6.11
0.07	4.22	7.11	8.92	9.93
0.07	5.45	9.15	11.46	12.74
0.07	10.58	17.76	22.25	24.74
0.07	18.60	31.22	39.10	43.48

R513A

0.2	0.6	1.6	2.0	
1.2	2.6	4.2	5.0	
3.8	4.5	6.4	7.6	
5.5	7.3	10.2	12.2	
10.0	11.8	16.6	19.8	
13.1	15.4	21.7	25.8	
25.4	30.0	42.2	50.2	
44.6	52.7	74.1	88.2	

R513A

NRVH 6 v2	0.1	0.3	1.3	1.9
NRVH 10 v2	0.0	2.6	4.6	6.0
NRVH 12 v2	5.1	8.5	9.2	9.9
NRVH 16 v2	1.8	9.7	12.8	14.7
NRVH 19 v2	14.8	22.0	24.0	25.8
NRVH 22	-	-	31.4	33.8
NRVH 28	-	-	60.9	65.6
NRVH 35	-	-	107.1	115.2

R515B

NRV 6 v2	1.2	4.0	9.6	12.5
NRV 10 v2	7.2	15.9	25.7	30.7
NRV 12 v2	23.4	27.7	39.1	46.8
NRV 16 v2	33.7	44.3	62.6	74.8
NRV 19 v2	60.8	71.9	101.7	121.6
NRV 22	79.5	94.1	133.0	159.0
NRV 28	154.3	182.6	258.2	308.6
NRV 35	271.2	320.9	453.8	542.4

R515B

0.07	0.16	0.30	0.40	0.45
0.07	0.67	1.25	1.61	1.81
0.07	1.27	2.25	2.86	3.21
0.07	2.04	3.60	4.58	5.13
0.07	3.31	5.84	7.44	8.33
0.07	4.33	7.64	9.73	10.90
0.07	8.40	14.84	18.89	21.16
0.07	14.77	26.08	33.21	37.18

R515B

0.2	0.6	1.4	1.8	
1.0	2.3	3.7	4.4	
3.4	4.0	5.6	6.6	
4.9	6.4	9.0	10.6	
8.8	10.4	14.6	17.3	
11.5	13.6	19.0	22.6	
22.3	26.3	36.9	43.8	
39.2	46.3	64.9	77.1	

R515B

NRVH 6 v2	0.1	0.3	1.1	1.6
NRVH 10 v2	0.0	2.3	4.0	5.2
NRVH 12 v2	4.5	7.4	8.0	8.6
NRVH 16 v2	1.6	8.4	11.0	12.7
NRVH 19 v2	12.9	19.2	20.9	22.5
NRVH 22	-	-	27.3	29.4
NRVH 28	-	-	53.1	57.0
NRVH 35	-	-	93.3	100.2

R1233zd(E)

NRV 6 v2	1.5	5.0	11.9	15.6
NRV 10 v2	9.0	19.8	31.9	38.2
NRV 12 v2	29.1	34.4	48.7	58.2
NRV 16 v2	42.0	55.1	77.9	93.1
NRV 19 v2	75.6	89.5	126.6	151.3
NRV 22	98.9	117.0	165.5	197.8
NRV 28	192.0	227.2	321.3	384.1
NRV 35	337.5	399.3	564.8	675.0

R1233zd(E)

0.07	0.04	0.11	0.18	0.22
0.07	0.17	0.52	0.79	0.93
0.07	0.42	1.11	1.54	1.77
0.07	0.67	1.78	2.46	2.83
0.07	1.10	2.89	3.99	4.60
0.07	1.43	3.78	5.22	6.02
0.07	2.78	7.34	10.13	11.68
0.07	4.89	12.90	17.81	20.53

R1233zd(E)

0.1	0.3	0.8	1.1	
0.6	1.4	2.3	2.6	
2.1	2.5	3.4	4.0	
3.1	4.0	5.5	6.4	
5.6	6.5	8.9	10.4	
7.3	8.5	11.7	13.6	
14.1	16.5	22.7	26.4	
24.8	29.1	39.9	46.4	

R1233zd(E)

NRVH 6 v2	0.0	0.1	0.6	0.8
NRVH 10 v2	0.0	1.3	2.2	2.9
NRVH 12 v2	2.7	4.4	4.7	4.9
NRVH 16 v2	0.8	4.5	5.9	6.8
NRVH 19 v2	7.7	11.4	12.1	12.8
NRVH 22	-	-	15.9	16.7
NRVH 28	-	-	30.8	32.5
NRVH 35	-	-	54.2	57.1

R1234ze(E)

NRV 6 v2	1.3	4.1	9.8	12.9
NRV 10 v2	7.4	16.3	26.4	31.5
NRV 12 v2	24.0	28.4	40.2	48.0
NRV 16 v2	34.6	45.4	64.3	76.8
NRV 19 v2	62.4	73.9	104.4	124.8
NRV 22	81.6	96.6	136.6	163.2
NRV 28	158.4	187.5	265.1	316.9
NRV 35	278.5	329.5	466.0	557.0

R1234ze(E)

0.07	0.16	0.31	0.41	0.46
0.07	0.69	1.28	1.64	1.85
0.07	1.31	2.30	2.93	3.27
0.07	2.09	3.68	4.68	5.24
0.07	3.40	5.98	7.61	8.51
0.07	4.45	7.82	9.95	11.13
0.07	8.64	15.19	19.31	21.60
0.07	15.18	26.69	33.94	37.97

R1234ze(E)

0.2	0.6	1.4	1.8	
1.1	2.3	3.8	4.5	
3.5	4.1	5.7	6.8	
5.0	6.5	9.2	10.9	
9.0	10.6	14.9	17.7	
11.7	13.9	19.5	23.1	
22.8	26.9	37.8	44.8	
40.1	47.3	66.4	78.8	

R1234ze(E)

NRVH 6 v2	0.1	0.3	1.2	1.7
NRVH 10 v2	0.0	2.3	4.1	5.3
NRVH 12 v2	4.6	7.6	8.2	8.8
NRVH 16 v2	1.6	8.6	11.3	13.0
NRVH 19 v2	13.2	19.6	21.4	23.0
NRVH 22	-	-	28.0	30.0
NRVH 28	-	-	54.3	58.3
NRVH 35	-	-	95.4	102.5

Correction factors for liquid temperature t_l

t _l [°C]	-10	0	10	15	20	25	30	35	40	45	50
R452A	0.67	0.74	0.83	0.88	0.93	1.00	1.08	1.17	1.28	1.41	1.59
R513A	0.71	0.77	0.85	0.89	0.94	1.00	1.06	1.14	1.22	1.32	1.44
R515B	0.72	0.78	0.86	0.90	0.95	1.00	1.06	1.13	1.20	1.29	1.40
R1233zd(E)	0.77	0.82	0.89	0.92	0.96	1.00	1.04	1.09	1.14	1.20	1.26
R1234ze(E)	0.72	0.78	0.86	0.90	0.95	1.00	1.06	1.12	1.20	1.29	1.39

Data sheet | Check valve, types NRV and NR VH

Capacity

SI units

Liquid capacity [kW]

Type	Liquid capacity ¹⁾ at pressure drop across valve Δp [bar]			
	NRV			
	0.05	0.07	0.14	0.2

R290				
NRV 6 v2	1.7	5.5	13.2	17.3
NRV 10 v2	10.0	22.0	35.5	42.4
NRV 12 v2	32.3	38.2	54.1	64.6
NRV 16 v2	46.6	61.2	86.5	103.4
NRV 19 v2	84.0	99.4	140.6	168.1
NRV 22	110.5	130.8	184.9	221.1
NRV 28	214.6	253.9	359.0	429.1
NRV 35	377.1	446.2	631.0	754.2

Suction vapour capacity in [kW]

Pressure drop across valve Δp [bar]	Suction vapour capacity ¹⁾ at evaporating temperature t _e [°C]			
	NRV			
	-30	-10	0	5

R290				
0.07	0.42	0.66	0.81	0.89
0.07	1.71	2.67	3.25	3.57
0.07	3.06	4.72	5.72	6.26
0.07	4.89	7.54	9.14	10.02
0.07	7.94	12.26	14.86	16.28
0.07	10.41	16.07	19.49	21.36
0.07	20.20	31.20	37.83	41.46
0.07	35.50	54.84	66.50	72.86

Hot gas capacity in [kW]

Type	Hot gas capacity ¹⁾ at pressure drop across valve Δp [bar]			
	NRV			
	0.05	0.07	0.14	0.2

R290				
0.3	1.0	2.5	3.3	
1.9	4.2	6.8	8.0	
6.2	7.3	10.3	12.3	
8.9	11.7	16.5	19.6	
16.1	19.0	26.8	31.9	
21.2	25.0	35.2	42.0	
41.1	48.6	68.4	81.5	
72.2	85.4	120.2	143.2	

Hot gas capacity in [kW]

Type	Hot gas capacity ¹⁾ at pressure drop across valve Δp [bar]			
	NRVH			
	0.2	0.25	0.3	0.35

R290				
NRVH 6 v2	0.2	0.5	2.1	3.1
NRVH 10 v2	0.0	4.3	7.4	9.7
NRVH 12 v2	8.3	13.7	14.9	16.1
NRVH 16 v2	2.9	15.7	20.7	23.8
NRVH 19 v2	23.9	35.6	38.8	41.8
NRVH 22	-	-	51.1	55.0
NRVH 28	-	-	99.2	106.8
NRVH 35	-	-	174.4	187.8

R32				
NRV 6 v2	2.1	6.9	16.6	21.8
NRV 10 v2	12.6	27.6	44.7	53.4
NRV 12 v2	40.7	48.1	68.1	81.4
NRV 16 v2	58.7	77.0	108.9	130.2
NRV 19 v2	105.8	125.1	177.0	211.5
NRV 22	138.3	163.7	231.4	276.6
NRV 28	268.5	317.7	449.3	537.0
NRV 35	471.9	558.3	789.6	943.8

R32				
0.07	0.58	0.87	1.05	1.14
0.07	2.33	3.50	4.18	4.55
0.07	4.12	6.14	7.32	7.96
0.07	6.59	9.83	11.72	12.73
0.07	10.72	15.97	19.04	20.69
0.07	14.01	20.89	24.90	27.06
0.07	27.20	40.54	48.34	52.52
0.07	47.81	71.26	84.95	92.31

R32				
0.4	1.4	3.4	4.4	
2.5	5.6	9.0	10.8	
8.2	9.7	13.8	16.4	
11.9	15.6	22.0	26.3	
21.4	25.3	35.8	42.7	
28.0	33.1	46.8	55.8	
54.4	64.3	90.8	108.3	
95.6	113.0	159.5	190.3	

R32				
NRVH 6 v2	0.2	0.7	2.9	4.2
NRVH 10 v2	0.0	5.8	10.0	13.0
NRVH 12 v2	11.1	18.3	20.0	21.6
NRVH 16 v2	3.9	21.2	28.0	32.2
NRVH 19 v2	32.0	47.6	52.1	56.2
NRVH 22	-	-	68.1	73.5
NRVH 28	-	-	132.2	142.6
NRVH 35	-	-	232.4	250.7

R452B				
NRV 6 v2	1.7	5.6	13.4	17.5
NRV 10 v2	10.1	22.2	35.8	42.8
NRV 12 v2	32.6	38.6	54.6	65.3
NRV 16 v2	47.1	61.8	87.4	104.4
NRV 19 v2	84.9	100.4	142.0	169.7
NRV 22	111.0	131.3	185.7	222.0
NRV 28	16.5	215.4	254.9	360.5
NRV 35	29.0	378.6	448.0	633.6

R452B				
0.07	0.47	0.72	0.87	0.96
0.07	1.90	2.90	3.50	3.82
0.07	3.37	5.10	6.13	6.68
0.07	5.39	8.16	9.80	10.69
0.07	8.75	13.26	15.93	17.38
0.07	11.45	17.34	20.83	22.72
0.07	22.22	33.66	40.44	44.11
0.07	39.05	59.16	71.07	77.52

R452B				
0.4	1.2	2.8	3.7	
2.2	4.7	7.6	9.1	
7.0	8.2	11.6	13.9	
10.1	13.2	18.6	22.2	
18.1	21.4	30.2	36.1	
23.7	28.0	39.5	47.2	
46.0	54.4	76.8	91.6	
80.9	95.6	134.9	161.0	

R452B				
NRVH 6 v2	0.2	0.6	2.5	3.5
NRVH 10 v2	0.0	4.9	8.4	11.0
NRVH 12 v2	9.4	15.5	16.9	18.3
NRVH 16 v2	3.3	17.9	23.6	27.2
NRVH 19 v2	27.1	40.3	44.0	47.5
NRVH 22	-	-	57.6	62.1
NRVH 28	-	-	111.8	120.5
NRVH 35	-	-	196.5	211.9

R455A				
NRV 6 v2	1.2	4.0	9.7	12.7
NRV 10 v2	7.3	16.0	25.9	31.0
NRV 12 v2	23.6	27.9	39.5	47.2
NRV 16 v2	34.1	44.7	63.2	75.6
NRV 19 v2	61.4	72.7	102.8	122.8
NRV 22	80.3	95.0	134.4	160.6
NRV 28	155.9	184.4	260.8	311.8
NRV 35	274.0	324.2	458.4	548.0

R455A				
0.07	0.28	0.47	0.58	0.64
0.07	1.15	1.88	2.34	2.58
0.07	2.06	3.32	4.10	4.54
0.07	3.29	5.32	6.57	7.26
0.07	5.35	8.64	10.67	11.79
0.07	7.00	11.30	13.96	15.42
0.07	13.59	21.94	27.09	29.93
0.07	23.88	38.57	47.62	52.61

R455A				
0.3	0.9	2.2	2.9	
1.7	3.7	5.9	7.1	
5.4	6.4	9.0	10.8	
7.8	10.3	14.5	17.3	
14.1	16.7	23.5	28.0	
18.4	21.8	30.8	36.7	
35.8	42.3	59.7	71.2	
62.9	74.4	104.9	125.1	

R455A				
NRVH 6 v2	0.2	0.4	1.9	2.7
NRVH 10 v2	0.0	3.8	6.6	8.5
NRVH 12 v2	7.3	12.0	13.2	14.2
NRVH 16 v2	2.6	13.9	18.3	21.1
NRVH 19 v2	21.0	31.3	34.2	36.9
NRVH 22	-	-	44.7	48.2
NRVH 28	-	-	86.8	93.6
NRVH 35	-	-	152.6	164.5

1) Rated capacities are based on:
 -Evaporating temperature, t_e = -10 °C.
 -Condensing temperature, t_c = 30 °C.
 -Subcooling t_{sub} = 5 K.
 -Delta superheat t_{sh} = 0 K.
 -Discharge temperature, t_d = 80 °C ahead of the valve.
 The table values refer to the evaporator capacity.

Correction factors

When selecting the evaporator capacity is to be multiplied by a correction factor depending on the liquid temperature t_l ahead of the valve/the evaporator. The corrected capacity can then be found from the table.

System capacity = Correction factor × Table capacity

Correction factors for liquid temperature t_l

t _l [°C]	-10	0	10	15	20	25	30	35	40	45	50
R290	0.73	0.79	0.86	0.90	0.95	1.00	1.06	1.12	1.19	1.28	1.38
R32	0.76	0.82	0.88	0.92	0.96	1.00	1.05	1.11	1.17	1.24	1.33
R452B	0.74	0.80	0.86	0.91	0.95	1.00	1.06	1.12	1.20	1.28	1.39
R455A	0.70	0.77	0.84	0.89	0.94	1.00	1.07	1.14	1.23	1.34	1.47

Data sheet | Check valve, types NRV and NR VH

SI units

Capacity

Liquid capacity [kW]

Type	Liquid capacity ¹⁾ at pressure drop across valve Δp [bar]			
	NRV			
	0.05	0.07	0.14	0.2

R454A				
NRV 6 v2	1.4	4.4	10.5	13.8
NRV 10 v2	8.0	17.5	28.3	33.8
NRV 12 v2	25.8	30.5	43.1	51.5
NRV 16 v2	37.2	48.8	69.0	82.5
NRV 19 v2	67.0	79.3	112.1	134.0
NRV 22	87.6	103.7	146.6	175.2
NRV 28	170.1	201.2	284.6	340.1
NRV 35	298.9	353.7	500.1	597.8

R454B				
NRV 6 v2	1.7	5.6	13.5	17.7
NRV 10 v2	10.2	22.5	36.3	43.4
NRV 12 v2	33.1	39.2	55.4	66.2
NRV 16 v2	47.8	62.7	88.6	105.9
NRV 19 v2	86.1	101.8	144.0	172.2
NRV 22	112.6	133.2	188.3	225.1
NRV 28	218.5	258.5	365.6	437.0
NRV 35	384.0	454.4	642.6	768.1

R454C				
NRV 6 v2	1.2	4.0	9.5	12.5
NRV 10 v2	7.2	15.8	25.5	30.5
NRV 12 v2	23.2	27.5	38.9	46.5
NRV 16 v2	33.5	44.0	62.2	74.4
NRV 19 v2	60.4	71.5	101.1	120.9
NRV 22	79.0	93.5	132.2	158.1
NRV 28	153.4	181.5	256.7	306.8
NRV 35	269.6	319.0	451.2	539.3

R516A				
NRV 6 v2	1.2	3.9	9.3	12.2
NRV 10 v2	7.1	15.5	25.0	29.9
NRV 12 v2	22.8	27.0	38.2	45.6
NRV 16 v2	32.9	43.2	61.0	73.0
NRV 19 v2	59.3	70.1	99.2	118.6
NRV 22	77.5	91.7	129.7	155.0
NRV 28	150.5	178.0	251.8	301.0
NRV 35	264.5	312.9	442.6	529.0

Suction vapour capacity in [kW]

Pressure drop across valve Δp [bar]	Suction vapour capacity ¹⁾ at evaporating temperature t _e [°C]			
	NRV			
	-30	-10	0	5

R454A				
0.07	0.33	0.53	0.65	0.72
0.07	1.33	2.13	2.62	2.89
0.07	2.37	3.76	4.60	5.07
0.07	3.80	6.02	7.37	8.11
0.07	6.17	9.77	11.97	13.18
0.07	8.07	12.78	15.65	17.23
0.07	15.66	24.81	30.39	33.45
0.07	27.53	43.61	53.41	58.78

R454B				
0.07	0.47	0.73	0.88	0.96
0.07	1.91	2.91	3.51	3.83
0.07	3.38	5.12	6.15	6.70
0.07	5.40	8.18	9.83	10.72
0.07	8.78	13.30	15.98	17.43
0.07	11.48	17.39	20.89	22.79
0.07	22.29	33.76	40.56	44.23
0.07	39.18	59.34	71.28	77.75

R454C				
0.07	0.27	0.45	0.56	0.62
0.07	1.10	1.82	2.26	2.50
0.07	1.98	3.21	3.97	4.39
0.07	3.17	5.14	6.35	7.03
0.07	5.15	8.35	10.33	11.42
0.07	6.73	10.92	13.50	14.93
0.07	13.07	21.19	26.21	28.99
0.07	22.96	37.25	46.07	50.94

R516A				
0.07	0.21	0.38	0.48	0.53
0.07	0.89	1.53	1.93	2.14
0.07	1.63	2.72	3.40	3.78
0.07	2.61	4.36	5.45	6.05
0.07	4.25	7.08	8.85	9.83
0.07	5.56	9.26	11.57	12.86
0.07	10.79	17.98	22.47	24.96
0.07	18.96	31.61	39.49	43.86

Hot gas capacity in [kW]

Hot gas capacity ¹⁾ at pressure drop across valve Δp [bar]	NRV			
	0.05	0.07	0.14	0.2

R454A				
0.3	1.0	2.3	3.0	
1.7	3.8	6.1	7.3	
5.6	6.6	9.4	11.2	
8.1	10.6	15.0	17.9	
14.6	17.3	24.4	29.1	
19.1	22.6	31.9	38.0	
37.1	43.9	61.9	73.7	
65.2	77.1	108.7	129.6	

R454B				
0.4	1.2	2.9	3.7	
2.2	4.8	7.7	9.2	
7.0	8.3	11.7	14.0	
10.1	13.3	18.7	22.3	
18.2	21.6	30.4	36.3	
23.9	28.2	39.8	47.5	
46.3	54.8	77.3	92.2	
81.4	96.2	135.8	162.0	

R454C				
0.3	0.8	2.0	2.7	
1.5	3.4	5.5	6.5	
5.0	5.9	8.3	9.9	
7.2	9.5	13.3	15.9	
13.0	15.4	21.7	25.8	
17.0	20.1	28.3	33.8	
33.0	39.0	55.0	65.6	
58.0	68.6	96.7	115.2	

R516A				
0.2	0.7	1.6	2.0	
1.2	2.6	4.2	5.0	
3.9	4.6	6.4	7.6	
5.6	7.3	10.3	12.2	
10.1	11.9	16.7	19.9	
13.1	15.5	21.8	26.0	
25.5	30.1	42.4	50.4	
44.9	53.0	74.5	88.6	

Hot gas capacity in [kW]

Type	Hot gas capacity ¹⁾ at pressure drop across valve Δp [bar]			
	NRVH			
	0.2	0.25	0.3	0.35

R454A				
NRVH 6 v2	0.2	0.5	2.0	2.8
NRVH 10 v2	0.0	3.9	6.8	8.8
NRVH 12 v2	7.6	12.5	13.6	14.7
NRVH 16 v2	2.7	14.4	19.0	21.8
NRVH 19 v2	21.8	32.4	35.4	38.2
NRVH 22	-	-	46.3	49.9
NRVH 28	-	-	89.9	97.0
NRVH 35	-	-	158.1	170.4

R454B				
NRVH 6 v2	0.2	0.6	2.5	3.5
NRVH 10 v2	0.0	4.9	8.5	11.1
NRVH 12 v2	9.5	15.6	17.0	18.4
NRVH 16 v2	3.4	18.1	23.8	27.3
NRVH 19 v2	27.2	40.5	44.3	47.8
NRVH 22	-	-	58.0	62.5
NRVH 28	-	-	112.5	121.3
NRVH 35	-	-	197.7	213.2

R454C				
NRVH 6 v2	0.1	0.4	1.7	2.5
NRVH 10 v2	0.0	3.5	6.0	7.8
NRVH 12 v2	6.7	11.1	12.1	13.0
NRVH 16 v2	2.4	12.8	16.9	19.4
NRVH 19 v2	19.4	28.8	31.5	33.9
NRVH 22	-	-	41.2	44.4
NRVH 28	-	-	79.9	86.1
NRVH 35	-	-	140.5	151.4

R516A				
NRVH 6 v2	0.1	0.3	1.3	1.9
NRVH 10 v2	0.0	2.7	4.6	6.0
NRVH 12 v2	5.2	8.5	9.3	10.0
NRVH 16 v2	1.8	9.7	12.8	14.7
NRVH 19 v2	14.9	22.1	24.1	26.0
NRVH 22	-	-	31.5	33.9
NRVH 28	-	-	61.2	65.9
NRVH 35	-	-	107.6	115.8

1) Rated capacities are based on:
 -Evaporating temperature, t_e = -10 °C.
 -Condensing temperature, t_c = 30 °C.
 -Subcooling t_{sub} = 5 K.
 -Delta superheat t_{sh} = 0 K.
 -Discharge temperature, t_d = 80 °C ahead of the valve.
 The table values refer to the evaporator capacity.

Correction factors

When selecting the evaporator capacity is to be multiplied by a correction factor depending on the liquid temperature t_l ahead of the valve/the evaporator. The corrected capacity can then be found from the table.

System capacity-Correction factor=Table capacity

Correction factors for liquid temperature t_l

t _l [°C]	-10	0	10	15	20	25	30	35	40	45	50
R454A	0.71	0.77	0.85	0.89	0.94	1.00	1.06	1.14	1.22	1.32	1.44
R454B	0.74	0.80	0.87	0.91	0.95	1.00	1.06	1.12	1.19	1.28	1.38
R454C	0.70	0.77	0.84	0.89	0.94	1.00	1.07	1.14	1.23	1.34	1.47
R516A	0.71	0.77	0.85	0.89	0.94	1.00	1.06	1.14	1.22	1.32	1.43

Data sheet | Check valve, types NRV and NR VH

SI units

Capacity

Liquid capacity (kW)

Type	Liquid capacity ¹⁾ at pressure drop across valve Δp [bar]			
	NRV			
	0.05	0.07	0.14	0.2

R600				
NRV 6 v2	1.9	6.2	15.0	19.6
NRV 10 v2	11.3	24.9	40.2	48.0
NRV 12 v2	36.6	43.3	61.2	73.2
NRV 16 v2	52.8	69.3	98.0	117.1
NRV 19 v2	95.2	112.6	159.2	190.3
NRV 22	124.4	147.2	208.2	248.9
NRV 28	241.6	285.8	404.2	483.1
NRV 35	424.5	502.3	710.4	849.1

R600a				
NRV 6 v2	1.7	5.5	13.3	17.4
NRV 10 v2	10.0	22.1	35.6	42.6
NRV 12 v2	32.5	38.4	54.3	64.9
NRV 16 v2	46.9	61.5	86.9	103.9
NRV 19 v2	84.4	99.9	141.3	168.8
NRV 22	110.4	130.6	184.7	220.8
NRV 28	214.3	253.5	358.6	428.6
NRV 35	376.6	445.6	630.2	753.2

R1234yf				
NRV 6 v2	1.1	3.4	8.1	10.7
NRV 10 v2	6.2	13.5	21.8	26.1
NRV 12 v2	19.9	23.5	33.3	39.8
NRV 16 v2	28.7	37.7	53.3	63.7
NRV 19 v2	51.7	61.2	86.6	103.5
NRV 22	67.9	80.4	113.7	135.9
NRV 28	131.9	156.0	220.7	263.8
NRV 35	231.8	274.2	387.8	463.6
R1270				
NRV 6 v2	1.8	5.7	13.7	18.0
NRV 10 v2	10.4	22.8	36.9	44.1
NRV 12 v2	33.6	39.8	56.2	67.2
NRV 16 v2	48.5	63.6	90.0	107.5
NRV 19 v2	87.4	103.4	146.2	174.7
NRV 22	114.2	135.2	191.2	228.5
NRV 28	221.8	262.4	371.1	443.5
NRV 35	389.8	461.2	652.2	779.5

Suction vapour capacity in [kW]

Pressure drop across valve Δp [bar]	Suction vapour capacity ¹⁾ at evaporating temperature t _e [°C]			
	NRV			
	-30	-10	0	5

R600				
0.07	0.12	0.29	0.40	0.45
0.07	0.58	1.25	1.64	1.86
0.07	1.25	2.34	3.00	3.37
0.07	2.01	3.74	4.80	5.40
0.07	3.26	6.07	7.81	8.77
0.07	4.27	7.94	10.21	11.47
0.07	8.28	15.42	19.82	22.26
0.07	14.55	27.10	34.83	39.12

R600a				
0.07	0.18	0.36	0.47	0.53
0.07	0.80	1.49	1.91	2.14
0.07	1.57	2.72	3.44	3.83
0.07	2.51	4.36	5.50	6.13
0.07	4.08	7.08	8.93	9.96
0.07	5.33	9.26	11.68	13.03
0.07	10.35	17.97	22.68	25.29
0.07	18.19	31.58	39.86	44.44

R1234yf				
0.07	0.19	0.34	0.44	0.49
0.07	0.80	1.39	1.76	1.97
0.07	1.47	2.48	3.11	3.47
0.07	2.34	3.96	4.98	5.55
0.07	3.81	6.44	8.09	9.01
0.07	5.00	8.44	10.61	11.81
0.07	9.71	16.39	20.59	22.93
0.07	17.07	28.81	36.19	40.31
R1270				
0.07	0.48	0.75	0.90	0.99
0.07	1.97	3.00	3.62	3.95
0.07	3.50	5.29	6.35	6.93
0.07	5.60	8.46	10.16	11.09
0.07	9.09	13.74	16.51	18.01
0.07	11.89	17.97	21.59	23.56
0.07	23.08	34.89	41.91	45.73
0.07	40.57	61.32	73.67	80.37

Hot gas capacity in [kW]

Hot gas capacity ¹⁾ at pressure drop across valve Δp [bar]	NRV			
	NRV			
	0.05	0.07	0.14	0.2

R600				
0.2	0.6	1.4	1.9	
1.1	2.4	3.9	4.6	
3.7	4.3	6.0	7.1	
5.3	6.9	9.6	11.3	
9.5	11.2	15.6	18.4	
12.5	14.7	20.4	24.1	
24.2	28.5	39.7	46.8	
42.6	50.2	69.8	82.2	

R600a				
0.2	0.7	1.6	2.1	
1.2	2.7	4.3	5.1	
4.0	4.7	6.6	7.8	
5.8	7.6	10.6	12.5	
10.4	12.3	17.2	20.4	
13.6	16.1	22.5	26.6	
26.5	31.2	43.7	51.7	
46.6	54.9	76.8	90.9	

R1234yf				
0.2	0.6	1.4	1.9	
1.1	2.4	3.8	4.5	
3.5	4.1	5.8	6.9	
5.0	6.6	9.3	11.1	
9.1	10.8	15.1	18.0	
11.9	14.1	19.8	23.5	
23.1	27.3	38.4	45.7	
40.6	48.0	67.5	80.3	
R1270				
0.4	1.2	2.8	3.7	
2.1	4.6	7.5	8.9	
6.9	8.1	11.4	13.6	
9.9	13.0	18.3	21.8	
17.8	21.1	29.7	35.4	
23.3	27.6	38.9	46.3	
45.3	53.5	75.4	89.9	
79.6	94.1	132.6	158.0	

Hot gas capacity in [kW]

Type	Hot gas capacity ¹⁾ at pressure drop across valve Δp [bar]			
	NRVH			
	0.2	0.25	0.3	0.35

R600				
NRVH 6 v2	0.1	0.3	1.1	1.6
NRVH 10 v2	0.0	2.4	4.1	5.4
NRVH 12 v2	4.8	7.8	8.5	9.0
NRVH 16 v2	1.6	8.6	11.3	13.0
NRVH 19 v2	13.7	20.4	22.0	23.5
NRVH 22	-	-	28.8	30.7
NRVH 28	-	-	55.9	59.7
NRVH 35	-	-	98.3	104.8

R600a				
NRVH 6 v2	0.1	0.3	1.3	1.9
NRVH 10 v2	0.0	2.7	4.6	6.0
NRVH 12 v2	5.3	8.7	9.4	10.1
NRVH 16 v2	1.8	9.7	12.8	14.7
NRVH 19 v2	15.2	22.6	24.5	26.3
NRVH 22	-	-	32.1	34.4
NRVH 28	-	-	62.3	66.7
NRVH 35	-	-	109.5	117.2

R1234yf				
NRVH 6 v2	0.1	0.3	1.2	1.7
NRVH 10 v2	0.0	2.4	4.2	5.4
NRVH 12 v2	4.7	7.7	8.4	9.0
NRVH 16 v2	1.6	8.8	11.6	13.3
NRVH 19 v2	13.5	20.0	21.8	23.5
NRVH 22	-	-	28.6	30.7
NRVH 28	-	-	55.4	59.6
NRVH 35	-	-	97.5	104.8
R1270				
NRVH 6 v2	0.2	0.6	2.4	3.4
NRVH 10 v2	0.0	4.8	8.3	10.8
NRVH 12 v2	9.2	15.2	16.6	17.9
NRVH 16 v2	3.3	17.5	23.1	26.6
NRVH 19 v2	26.6	39.5	43.2	46.5
NRVH 22	-	-	56.5	60.8
NRVH 28	-	-	109.6	118.1
NRVH 35	-	-	192.6	207.5

1) Rated capacities are based on:
 -Evaporating temperature, t_e = -10 °C.
 -Condensing temperature, t_c = 30 °C.
 -Subcooling t_{sub} = 5 K.
 -Delta superheat t_{sh} = 0 K.
 -Discharge temperature, t_d = 80 °C ahead of the valve.
 The table values refer to the evaporator capacity.

Correction factors

When selecting the evaporator capacity is to be multiplied by a correction factor depending on the liquid temperature t_l ahead of the valve/the evaporator. The corrected capacity can then be found from the table.

System capacity = Correction factor × Table capacity

Correction factors for liquid temperature t_l

t _l [°C]	-10	0	10	15	20	25	30	35	40	45	50
R600	0.77	0.82	0.88	0.92	0.96	1.00	1.05	1.10	1.15	1.22	1.29
R600a	0.75	0.81	0.87	0.91	0.95	1.00	1.05	1.11	1.17	1.25	1.33
R1234yf	0.69	0.76	0.84	0.89	0.94	1.00	1.07	1.15	1.24	1.36	1.49
R1270	0.74	0.80	0.87	0.91	0.95	1.00	1.06	1.12	1.19	1.27	1.37

Note:
 - For capacity calculation of other refrigerants, please contact Danfoss.

Data sheet | Check valve, types NRV and NRHV

Capacity

US units

Liquid capacity [TR]

Type	Liquid capacity ¹⁾ at pressure drop across valve Δp [psi]			
	NRV			
	0.7	1	2	3

R134a

NRV 6 v2	0.3	1.3	3.1	4.2
NRV 10 v2	2.1	5.1	8.3	10.2
NRV 12 v2	7.5	9.0	12.7	15.6
NRV 16 v2	10.7	14.3	20.4	24.9
NRV 19 v2	19.6	23.4	33.1	40.5
NRV 22	25.6	30.6	43.3	53.0
NRV 28	49.7	59.4	84.0	102.9
NRV 35	87.3	104.4	147.6	180.8

R22

NRV 6 v2	0.4	1.4	3.3	4.5
NRV 10 v2	2.2	5.5	8.9	11.0
NRV 12 v2	8.1	9.7	13.7	16.7
NRV 16 v2	11.5	15.4	21.9	26.8
NRV 19 v2	21.0	25.1	35.5	43.5
NRV 22	27.5	32.9	46.5	56.9
NRV 28	53.4	63.8	90.2	110.5
NRV 35	93.8	112.1	158.5	194.1

R404A

NRV 6 v2	0.2	0.9	2.3	3.1
NRV 10 v2	1.5	3.7	6.1	7.5
NRV 12 v2	5.5	6.6	9.3	11.4
NRV 16 v2	7.9	10.5	14.9	18.2
NRV 19 v2	14.3	17.1	24.2	29.6
NRV 22	18.7	22.4	31.7	38.8
NRV 28	36.4	43.5	61.5	75.3
NRV 35	63.9	76.4	108.0	132.3

R410A

NRV 6 v2	0.3	1.3	3.3	4.4
NRV 10 v2	2.2	5.4	8.8	10.8
NRV 12 v2	7.9	9.5	13.4	16.4
NRV 16 v2	11.3	15.1	21.5	26.3
NRV 19 v2	20.7	24.7	34.9	42.8
NRV 22	27.0	32.3	45.7	55.9
NRV 28	52.4	62.7	88.6	108.5
NRV 35	92.2	110.1	155.8	190.8

Suction vapour capacity [TR]

Pressure drop across valve Δp [psi]	Suction vapour capacity ¹⁾ at evaporating temperature t_e [°F]			
	NRV			
	-20	15	32	40

R134a

1	0.06	0.11	0.14	0.15
1	0.26	0.45	0.56	0.62
1	0.49	0.81	1.01	1.11
1	0.78	1.29	1.60	1.76
1	1.28	2.11	2.61	2.87
1	1.67	2.77	3.42	3.76
1	3.25	5.37	6.64	7.29
1	5.71	9.44	11.67	12.82

R22

1	0.10	0.15	0.18	0.20
1	0.40	0.62	0.74	0.80
1	0.72	1.10	1.31	1.42
1	1.15	1.74	2.08	2.25
1	1.88	2.85	3.40	3.68
1	2.46	3.72	4.45	4.82
1	4.77	7.23	8.63	9.35
1	8.39	12.70	15.18	16.43

R404A

1	0.08	0.13	0.16	0.18
1	0.34	0.54	0.66	0.72
1	0.61	0.96	1.16	1.27
1	0.96	1.52	1.85	2.02
1	1.58	2.48	3.02	3.30
1	2.06	3.25	3.95	4.32
1	4.00	6.30	7.67	8.38
1	7.03	11.08	13.49	14.73

R410A

1	0.12	0.19	0.23	0.25
1	0.51	0.77	0.93	1.00
1	0.91	1.37	1.64	1.77
1	1.45	2.18	2.60	2.81
1	2.37	3.57	4.25	4.60
1	3.10	4.66	5.56	6.01
1	6.03	9.05	10.79	11.68
1	10.59	15.91	18.97	20.52

Hot gas capacity [TR]

Hot gas capacity ¹⁾ at pressure drop across valve Δp [psi]	NRV			
	NRV			
	0.7	1	2	4

R134a

0.0	0.2	0.4	0.6
0.3	0.7	1.1	1.6
1.0	1.2	1.7	2.4
1.4	1.9	2.7	3.8
2.6	3.1	4.4	6.1
3.4	4.1	5.7	8.0
6.7	7.9	11.2	15.6
11.7	14.0	19.6	27.4

R22

0.1	0.2	0.5	0.8
0.3	0.8	1.4	1.9
1.3	1.5	2.1	3.0
1.8	2.4	3.4	4.7
3.3	3.9	5.5	7.7
4.3	5.1	7.2	10.1
8.3	9.9	13.9	19.6
14.6	17.4	24.5	34.4

R404A

0.0	0.2	0.4	0.7
0.3	0.7	1.2	1.7
1.1	1.3	1.8	2.5
1.5	2.0	2.9	4.0
2.8	3.3	4.7	6.6
3.6	4.3	6.1	8.6
7.1	8.4	11.9	16.7
12.4	14.8	20.9	29.3

R410A

0.1	0.3	0.6	1.0
0.4	1.0	1.7	2.4
1.5	1.8	2.6	3.6
2.2	2.9	4.1	5.8
3.9	4.7	6.7	9.4
5.2	6.2	8.7	12.3
10.0	12.0	16.9	23.8
17.6	21.0	29.7	41.8

Hot gas capacity [TR]

Type	Hot gas capacity ¹⁾ at pressure drop across valve Δp [psi]			
	NRVH			
	3	4	5	6

R134a

NRVH 6 v2	0.0	0.1	0.5	0.6
NRVH 10 v2	0.1	1.0	1.6	1.9
NRVH 12 v2	1.6	2.4	2.6	2.9
NRVH 16 v2	0.7	3.1	3.9	4.4
NRVH 19 v2	4.3	6.1	6.8	7.4
NRVH 22	7.0	8.0	8.9	9.7
NRVH 28	13.6	15.6	17.3	18.9
NRVH 35	23.9	27.4	30.5	33.2

R22

NRVH 6 v2	0.0	0.2	0.6	0.8
NRVH 10 v2	0.1	1.2	2.0	2.4
NRVH 12 v2	2.1	3.0	3.3	3.6
NRVH 16 v2	0.8	3.9	4.9	5.6
NRVH 19 v2	5.4	7.7	8.6	9.4
NRVH 22	8.8	10.1	11.2	12.3
NRVH 28	17.0	19.6	21.8	23.8
NRVH 35	29.9	34.4	38.3	41.8

R404A

NRVH 6 v2	0.0	0.1	0.5	0.7
NRVH 10 v2	0.1	1.1	1.7	2.0
NRVH 12 v2	1.8	2.5	2.8	3.1
NRVH 16 v2	0.7	3.3	4.2	4.8
NRVH 19 v2	4.6	6.6	7.3	8.0
NRVH 22	7.5	8.6	9.6	10.5
NRVH 28	14.5	16.7	18.6	20.3
NRVH 35	25.5	29.3	32.7	35.7

R410A

NRVH 6 v2	0.1	0.2	0.8	0.9
NRVH 10 v2	0.2	1.5	2.4	2.9
NRVH 12 v2	2.5	3.6	4.0	4.4
NRVH 16 v2	1.0	4.7	6.0	6.8
NRVH 19 v2	6.6	9.4	10.5	11.4
NRVH 22	10.6	12.3	13.7	14.9
NRVH 28	20.6	23.8	26.5	29.0
NRVH 35	36.3	41.8	46.6	51.0

¹⁾ Rated capacities are based on:

-Evaporating temperature, $t_e = 14^\circ\text{F}$

-Condensing temperature, $t_c = 86^\circ\text{F}$

-Subcooling $t_{\text{sub}} = 9^\circ\text{F}$

-Superheat $t_{\text{sh}} = 0^\circ\text{F}$

-Discharge temperature, $t_d = 176^\circ\text{F}$ ahead of the valve.

The table values refer to the evaporator capacity.

Correction factors

When selecting the evaporator capacity is to be multiplied by a correction factor depending on the liquid temperature t_l ahead of the valve/the evaporator. The corrected capacity can then be found from the table.

System capacity = Correction factor × Table capacity

Correction factors for liquid temperature t_l

t_l [°F]	15	32	50	60	70	80	86	95	105	115	125
R134a	0.74	0.79	0.86	0.91	0.96	1.02	1.08	1.16	1.24	1.34	1.46
R22	0.77	0.82	0.88	0.92	0.97	1.02	1.07	1.13	1.20	1.28	1.38
R404A	0.67	0.74	0.82	0.88	0.95	1.02	1.12	1.23	1.38	1.57	1.83
R410A	0.72	0.78	0.85	0.90	0.96	1.02	1.09	1.18	1.29	1.43	1.60

Data sheet | Check valve, types NRV and NRHV

Capacity

US units

Liquid capacity [TR]

Type	Liquid capacity ¹⁾ at pressure drop across valve Δp [psi]			
	NRV			
	0.7	1	2	3

R407A				
NRV 6 v2	0.3	1.2	3.0	4.0
NRV 10 v2	2.0	4.9	8.0	9.8
NRV 12 v2	7.2	8.6	12.2	14.9
NRV 16 v2	10.3	13.7	19.4	23.8
NRV 19 v2	18.7	22.3	31.6	38.7
NRV 22	24.4	29.2	41.3	50.6
NRV 28	47.5	56.7	80.2	98.2
NRV 35	83.4	99.7	141.0	172.7

Suction vapour capacity [TR]

Pressure drop across valve Δp [psi]	Suction vapour capacity ¹⁾ at evaporating temperature t _e [°F]			
	NRV			
	-20	15	32	40

R407A				
1	0.08	0.14	0.17	0.19
1	0.35	0.57	0.69	0.76
1	0.63	1.01	1.23	1.34
1	1.01	1.60	1.96	2.14
1	1.65	2.62	3.20	3.50
1	2.15	3.43	4.18	4.57
1	4.18	6.66	8.12	8.87
1	7.34	11.70	14.27	15.60

Hot gas capacity [TR]

Type	Hot gas capacity ¹⁾ at pressure drop across valve Δp [psi]			
	NRV			
	0.7	1	2	4

R407A				
0.1	0.2	0.5	0.8	
0.3	0.9	1.4	2.0	
1.3	1.5	2.1	3.0	
1.8	2.4	3.4	4.8	
3.3	4.0	5.6	7.9	
4.3	5.2	7.3	10.3	
8.4	10.1	14.2	19.9	
14.8	17.7	24.9	35.1	

Hot gas capacity [TR]

Type	Hot gas capacity ¹⁾ at pressure drop across valve Δp [psi]			
	NRHV			
	3	4	5	6

R407A				
NRHV 6 v2	0.0	0.2	0.6	0.8
NRHV 10 v2	0.1	1.3	2.0	2.4
NRHV 12 v2	2.1	3.0	3.4	3.7
NRHV 16 v2	0.9	4.0	5.0	5.7
NRHV 19 v2	5.5	7.9	8.8	9.6
NRHV 22	8.9	10.3	11.5	12.5
NRHV 28	17.3	19.9	22.2	24.3
NRHV 35	30.4	35.1	39.1	42.7

R407C

NRV 6 v2	0.3	1.3	3.2	4.3
NRV 10 v2	2.1	5.3	8.6	10.5
NRV 12 v2	7.8	9.3	13.1	16.1
NRV 16 v2	11.1	14.7	21.0	25.7
NRV 19 v2	20.2	24.1	34.1	41.7
NRV 22	26.4	31.5	44.6	54.6
NRV 28	51.2	61.2	86.5	106.0
NRV 35	90.0	107.5	152.1	186.3

R407C

1	0.08	0.14	0.17	0.19
1	0.35	0.57	0.70	0.77
1	0.64	1.02	1.24	1.36
1	1.02	1.62	1.98	2.16
1	1.66	2.65	3.24	3.53
1	2.18	3.47	4.23	4.62
1	4.22	6.73	8.21	8.97
1	7.42	11.83	14.43	15.77

R407C

0.1	0.2	0.5	0.8
0.4	0.9	1.5	2.0
1.3	1.6	2.2	3.1
1.9	2.5	3.5	5.0
3.4	4.1	5.8	8.1
4.5	5.3	7.5	10.6
8.7	10.4	14.6	20.6
15.3	18.2	25.7	36.1

R407C

NRHV 6 v2	0.0	0.2	0.7	0.8
NRHV 10 v2	0.2	1.3	2.1	2.5
NRHV 12 v2	2.2	3.1	3.5	3.8
NRHV 16 v2	0.9	4.1	5.1	5.9
NRHV 19 v2	5.7	8.1	9.0	9.9
NRHV 22	9.2	10.6	11.8	12.9
NRHV 28	17.9	20.6	22.9	25.0
NRHV 35	31.4	36.1	40.3	44.0

R407F

NRV 6 v2	0.3	1.3	3.2	4.4
NRV 10 v2	2.1	5.4	8.7	10.7
NRV 12 v2	7.9	9.4	13.3	16.3
NRV 16 v2	11.2	15.0	21.3	26.1
NRV 19 v2	20.5	24.5	34.6	42.4
NRV 22	26.8	32.0	45.3	55.5
NRV 28	52.0	62.1	87.9	107.6
NRV 35	91.4	109.2	154.5	189.2

R407F

1	0.09	0.15	0.18	0.20
1	0.38	0.62	0.75	0.82
1	0.70	1.10	1.33	1.45
1	1.11	1.74	2.12	2.31
1	1.81	2.85	3.46	3.77
1	2.36	3.72	4.52	4.93
1	4.59	7.23	8.78	9.57
1	8.07	12.71	15.43	16.82

R407F

0.1	0.2	0.6	0.9
0.4	0.9	1.5	2.1
1.4	1.7	2.3	3.3
2.0	2.6	3.7	5.2
3.6	4.3	6.1	8.5
4.7	5.6	7.9	11.1
9.1	10.9	15.4	21.6
16.0	19.2	27.0	38.0

R407F

NRHV 6 v2	0.0	0.2	0.7	0.8
NRHV 10 v2	0.2	1.4	2.2	2.6
NRHV 12 v2	2.3	3.3	3.7	4.0
NRHV 16 v2	0.9	4.3	5.4	6.2
NRHV 19 v2	6.0	8.5	9.5	10.4
NRHV 22	9.7	11.1	12.4	13.6
NRHV 28	18.8	21.6	24.1	26.3
NRHV 35	33.0	38.0	42.4	46.3

R407H

NRV 6 v2	0.4	1.4	3.5	4.7
NRV 10 v2	2.3	5.7	9.3	11.4
NRV 12 v2	8.4	10.1	14.2	17.4
NRV 16 v2	12.0	16.0	22.8	27.9
NRV 19 v2	21.9	26.2	37.0	45.3
NRV 22	28.6	34.2	48.4	59.3
NRV 28	55.6	66.5	94.0	115.1
NRV 35	97.7	116.8	165.2	202.3

R407H

1	0.09	0.15	0.18	0.20
1	0.38	0.62	0.75	0.82
1	0.70	1.10	1.33	1.45
1	1.11	1.75	2.12	2.31
1	1.81	2.86	3.47	3.78
1	2.37	3.73	4.54	4.95
1	4.59	7.25	8.81	9.60
1	8.07	12.74	15.48	16.88

R407H

0.1	0.2	0.6	0.9
0.4	1.0	1.6	2.2
1.4	1.7	2.4	3.3
2.0	2.7	3.8	5.4
3.7	4.4	6.2	8.7
4.8	5.7	8.1	11.4
9.3	11.2	15.7	22.1
16.4	19.6	27.6	38.8

R407H

NRHV 6 v2	0.0	0.2	0.7	0.9
NRHV 10 v2	0.2	1.4	2.2	2.7
NRHV 12 v2	2.3	3.3	3.7	4.1
NRHV 16 v2	1.0	4.4	5.5	6.3
NRHV 19 v2	6.1	8.7	9.7	10.6
NRHV 22	9.9	11.4	12.7	13.9
NRHV 28	19.2	22.1	24.6	26.9
NRHV 35	33.7	38.8	43.3	47.3

1) Rated capacities are based on:

-Evaporating temperature, t_e = 14 °F

-Condensing temperature, t_c = 86 °F

-Subcooling t_{sub} = 9 °F

-Superheat t_{sh} = 0 °F

-Discharge temperature, t_d = 176 °F ahead of the valve.

The table values refer to the evaporator capacity.

Correction factors

When selecting the evaporator capacity is to be multiplied by a correction factor depending on the liquid temperature t_l ahead of the valve/the evaporator. The corrected capacity can then be found from the table.

System capacity-Correction factor=Table capacity

Correction factors for liquid temperature t_l

t _l [°F]	15	32	50	60	70	80	86	95	105	115	125
R407A	0.72	0.78	0.85	0.90	0.96	1.02	1.09	1.18	1.28	1.41	1.56
R407C	0.73	0.79	0.86	0.91	0.96	1.02	1.09	1.17	1.26	1.37	1.51
R407F	0.73	0.79	0.86	0.91	0.96	1.02	1.09	1.17	1.26	1.38	1.52
R407H	0.74	0.80	0.87	0.91	0.96	1.02	1.08	1.16	1.24	1.35	1.47

Data sheet | Check valve, types NRV and NRHV

Capacity

US units

Liquid capacity [TR]

Type	Liquid capacity ¹⁾ at pressure drop across valve Δp [psi]			
	NRV			
	0.7	1	2	3

R448A				
NRV 6 v2	0.3	1.2	3.0	4.0
NRV 10 v2	2.0	4.9	8.0	9.8
NRV 12 v2	7.2	8.6	12.2	14.9
NRV 16 v2	10.3	13.7	19.5	23.9
NRV 19 v2	18.7	22.4	31.7	38.8
NRV 22	24.5	29.3	41.4	50.7
NRV 28	47.6	56.8	80.4	98.5
NRV 35	83.6	99.9	141.3	173.0

Suction vapour capacity [TR]

Pressure drop across valve Δp [psi]	Suction vapour capacity ¹⁾ at evaporating temperature t _e [°F]			
	NRV			
	-20	15	32	40

R448A				
1	0.09	0.14	0.17	0.19
1	0.36	0.58	0.71	0.77
1	0.65	1.03	1.26	1.37
1	1.04	1.64	2.00	2.18
1	1.70	2.69	3.27	3.57
1	2.23	3.51	4.27	4.66
1	4.32	6.82	8.30	9.05
1	7.59	11.99	14.58	15.91

Hot gas capacity [TR]

Type	Hot gas capacity ¹⁾ at pressure drop across valve Δp [psi]			
	NRV			
	0.7	1	2	4

R448A				
0.1	0.2	0.5	0.8	
0.4	0.9	1.4	2.0	
1.3	1.5	2.2	3.1	
1.8	2.5	3.5	4.9	
3.4	4.0	5.7	8.0	
4.4	5.3	7.4	10.4	
8.6	10.2	14.4	20.3	
15.1	18.0	25.3	35.6	

Hot gas capacity [TR]

Type	Hot gas capacity ¹⁾ at pressure drop across valve Δp [psi]			
	NRVH			
	3	4	5	6

R448A				
NRVH 6 v2	0.0	0.2	0.6	0.8
NRVH 10 v2	0.1	1.3	2.0	2.5
NRVH 12 v2	2.1	3.1	3.4	3.7
NRVH 16 v2	0.9	4.0	5.1	5.8
NRVH 19 v2	5.6	8.0	8.9	9.7
NRVH 22	9.1	10.4	11.6	12.7
NRVH 28	17.6	20.3	22.6	24.7
NRVH 35	30.9	35.6	39.7	43.4

R449A

NRV 6 v2	0.3	1.2	2.9	3.9
NRV 10 v2	1.9	4.8	7.9	9.7
NRV 12 v2	7.1	8.5	12.0	14.7
NRV 16 v2	10.2	13.5	19.3	23.6
NRV 19 v2	18.5	22.1	31.3	38.3
NRV 22	24.2	28.9	40.9	50.1
NRV 28	47.0	56.2	79.4	97.3
NRV 35	82.6	98.7	139.6	170.9

R449A

1	0.09	0.14	0.17	0.19
1	0.36	0.58	0.70	0.77
1	0.65	1.03	1.25	1.36
1	1.03	1.63	1.99	2.17
1	1.69	2.67	3.25	3.54
1	2.21	3.49	4.24	4.63
1	4.29	6.77	8.24	8.99
1	7.54	11.90	14.48	15.80

R449A

0.1	0.2	0.5	0.8	
0.3	0.9	1.4	2.0	
1.3	1.5	2.2	3.0	
1.8	2.4	3.4	4.8	
3.3	4.0	5.6	7.9	
4.3	5.2	7.3	10.3	
8.4	10.1	14.2	20.0	
14.8	17.7	25.0	35.1	

R449A

NRVH 6 v2	0.0	0.2	0.6	0.8
NRVH 10 v2	0.1	1.3	2.0	2.4
NRVH 12 v2	2.1	3.0	3.4	3.7
NRVH 16 v2	0.9	4.0	5.0	5.7
NRVH 19 v2	5.5	7.9	8.8	9.6
NRVH 22	8.9	10.3	11.5	12.5
NRVH 28	17.4	20.0	22.3	24.3
NRVH 35	30.5	35.1	39.1	42.7

R449B

NRV 6 v2	0.3	1.2	3.0	4.0
NRV 10 v2	2.0	4.9	8.0	9.8
NRV 12 v2	7.2	8.6	12.2	14.9
NRV 16 v2	10.3	13.7	19.5	23.9
NRV 19 v2	18.8	22.4	31.7	38.8
NRV 22	24.5	29.3	41.5	50.8
NRV 28	47.6	56.9	80.5	98.6
NRV 35	83.7	100.1	141.5	173.3

R449B

1	0.09	0.14	0.17	0.19
1	0.36	0.58	0.71	0.78
1	0.66	1.04	1.26	1.37
1	1.04	1.65	2.00	2.19
1	1.71	2.69	3.27	3.57
1	2.23	3.52	4.28	4.67
1	4.33	6.84	8.31	9.07
1	7.62	12.02	14.61	15.94

R449B

0.1	0.2	0.5	0.8	
0.4	0.9	1.4	2.0	
1.3	1.5	2.2	3.1	
1.8	2.5	3.5	4.9	
3.4	4.0	5.7	8.0	
4.4	5.2	7.4	10.4	
8.5	10.2	14.4	20.2	
15.0	17.9	25.2	35.5	

R449B

NRVH 6 v2	0.0	0.2	0.6	0.8
NRVH 10 v2	0.1	1.3	2.0	2.4
NRVH 12 v2	2.1	3.1	3.4	3.7
NRVH 16 v2	0.9	4.0	5.0	5.8
NRVH 19 v2	5.6	8.0	8.9	9.7
NRVH 22	9.0	10.4	11.6	12.7
NRVH 28	17.5	20.2	22.5	24.6
NRVH 35	30.8	35.5	39.6	43.2

R450A

NRV 6 v2	0.3	1.2	2.9	3.9
NRV 10 v2	1.9	4.7	7.7	9.5
NRV 12 v2	7.0	8.3	11.8	14.4
NRV 16 v2	9.9	13.3	18.8	23.1
NRV 19 v2	18.1	21.7	30.6	37.5
NRV 22	23.7	28.3	40.0	49.0
NRV 28	46.0	55.0	77.7	95.2
NRV 35	80.8	96.6	136.6	167.3

R450A

1	0.05	0.10	0.12	0.14
1	0.23	0.40	0.50	0.56
1	0.43	0.73	0.90	1.00
1	0.68	1.15	1.44	1.58
1	1.12	1.89	2.35	2.59
1	1.46	2.47	3.07	3.39
1	2.84	4.79	5.97	6.57
1	4.99	8.42	10.48	11.56

R450A

0.0	0.2	0.4	0.6	
0.2	0.6	1.0	1.4	
0.9	1.1	1.5	2.1	
1.3	1.7	2.5	3.4	
2.4	2.8	4.0	5.6	
3.1	3.7	5.2	7.3	
6.1	7.2	10.1	14.2	
10.6	12.7	17.8	24.9	

R450A

NRVH 6 v2	0.0	0.1	0.4	0.5
NRVH 10 v2	0.1	0.9	1.4	1.7
NRVH 12 v2	1.5	2.1	2.4	2.6
NRVH 16 v2	0.6	2.8	3.5	4.0
NRVH 19 v2	3.9	5.6	6.2	6.7
NRVH 22	6.4	7.3	8.1	8.8
NRVH 28	12.3	14.2	15.7	17.1
NRVH 35	21.7	24.9	27.6	30.1

1) Rated capacities are based on:
 -Evaporating temperature, t_e = 14 °F
 -Condensing temperature, t_c = 86 °F
 -Subcooling t_{sub} = 9 °F
 -Superheat t_{sh} = 0 °F
 -Discharge temperature, t_d = 176 °F ahead of the valve.
 The table values refer to the evaporator capacity.

Correction factors

When selecting the evaporator capacity is to be multiplied by a correction factor depending on the liquid temperature t_l ahead of the valve/the evaporator. The corrected capacity can then be found from the table.

$$\text{System capacity} \cdot \text{Correction factor} = \text{Table capacity}$$

Correction factors for liquid temperature t_l

t _l [°F]	15	32	50	60	70	80	86	95	105	115	125
R448A	0.72	0.78	0.85	0.90	0.96	1.02	1.09	1.18	1.28	1.41	1.56
R449A	0.72	0.77	0.85	0.90	0.96	1.02	1.09	1.18	1.29	1.41	1.57
R449B	0.72	0.78	0.85	0.90	0.96	1.02	1.09	1.18	1.28	1.41	1.56
R450A	0.73	0.79	0.86	0.91	0.96	1.02	1.09	1.16	1.25	1.36	1.49

Data sheet | Check valve, types NRV and NR VH

Capacity

US units

Liquid capacity (kW)

Type	Liquid capacity ¹⁾ at pressure drop across valve Δp [bar]			
	NRV			
	0.05	0.07	0.14	0.2

R452A	0.05	0.07	0.14	0.2
NRV 6 v2	0.2	0.9	2.3	3.1
NRV 10 v2	1.5	3.8	6.2	7.6
NRV 12 v2	5.6	6.6	9.4	11.5
NRV 16 v2	7.9	10.6	15.0	18.4
NRV 19 v2	14.5	17.3	24.4	29.9
NRV 22	18.9	22.6	32.0	39.1
NRV 28	36.7	43.9	62.0	76.0
NRV 35	64.5	77.1	109.1	133.6

Suction vapour capacity in [kW]

Pressure drop across valve Δp [bar]	Suction vapour capacity ¹⁾ at evaporating temperature t _e [°C]			
	NRV			
	-30	-10	0	5

R452A	-30	-10	0	5
1	0.08	0.13	0.15	0.17
1	0.32	0.51	0.63	0.69
1	0.57	0.91	1.12	1.22
1	0.91	1.45	1.78	1.94
1	1.49	2.37	2.90	3.18
1	1.95	3.11	3.80	4.15
1	3.78	6.03	7.37	8.06
1	6.65	10.59	12.95	14.17

Hot gas capacity in [kW]

Type	Hot gas capacity ¹⁾ at pressure drop across valve Δp [bar]			
	NRV			
	0.05	0.07	0.14	0.2

R452A	0.05	0.07	0.14	0.2
0.0	0.2	0.4	0.7	
0.3	0.7	1.2	1.7	
1.1	1.3	1.8	2.6	
1.6	2.1	2.9	4.1	
2.8	3.4	4.8	6.7	
3.7	4.4	6.3	8.8	
7.2	8.6	12.1	17.1	
12.7	15.1	21.4	30.0	

Hot gas capacity in [kW]

Type	Hot gas capacity ¹⁾ at pressure drop across valve Δp [bar]			
	NRVH			
	0.2	0.25	0.3	0.35

R452A	0.2	0.25	0.3	0.35
NRVH 6 v2	0.0	0.2	0.5	0.7
NRVH 10 v2	0.1	1.1	1.7	2.1
NRVH 12 v2	1.8	2.6	2.9	3.2
NRVH 16 v2	0.7	3.4	4.3	4.9
NRVH 19 v2	4.7	6.7	7.5	8.2
NRVH 22	7.6	8.8	9.8	10.7
NRVH 28	14.8	17.1	19.0	20.8
NRVH 35	26.1	30.0	33.5	36.5

R513A

NRV 6 v2	0.3	1.1	2.6	3.5
NRV 10 v2	1.7	4.3	6.9	8.5
NRV 12 v2	6.3	7.5	10.6	13.0
NRV 16 v2	8.9	11.9	16.9	20.7
NRV 19 v2	16.3	19.5	27.5	33.7
NRV 22	21.3	25.4	36.0	44.1
NRV 28	41.3	49.4	69.9	85.6
NRV 35	72.6	86.8	122.8	150.4

R513A

1	0.06	0.10	0.13	0.14
1	0.25	0.43	0.53	0.59
1	0.47	0.77	0.95	1.05
1	0.74	1.22	1.51	1.66
1	1.22	2.00	2.47	2.72
1	1.59	2.62	3.24	3.56
1	3.09	5.08	6.28	6.90
1	5.42	8.93	11.04	12.13

R513A

0.0	0.2	0.4	0.6
0.2	0.6	1.0	1.4
0.9	1.1	1.5	2.2
1.3	1.8	2.5	3.5
2.4	2.9	4.0	5.6
3.1	3.7	5.3	7.4
6.1	7.3	10.2	14.3
10.7	12.8	18.0	25.1

R513A

NRVH 6 v2	0.0	0.1	0.5	0.6
NRVH 10 v2	0.1	0.9	1.4	1.7
NRVH 12 v2	1.5	2.2	2.4	2.6
NRVH 16 v2	0.6	2.8	3.5	4.0
NRVH 19 v2	4.0	5.6	6.3	6.8
NRVH 22	6.4	7.4	8.2	8.9
NRVH 28	12.4	14.3	15.9	17.3
NRVH 35	21.9	25.1	27.9	30.4

R515B

NRV 6 v2	0.3	1.1	2.7	3.6
NRV 10 v2	1.8	4.4	7.2	8.9
NRV 12 v2	6.5	7.8	11.0	13.5
NRV 16 v2	9.3	12.4	17.7	21.6
NRV 19 v2	17.0	20.3	28.7	35.2
NRV 22	22.2	26.5	37.5	46.0
NRV 28	43.1	51.5	72.9	89.2
NRV 35	75.8	90.6	128.1	156.8

R515B

1	0.04	0.09	0.11	0.12
1	0.20	0.35	0.45	0.50
1	0.37	0.64	0.81	0.89
1	0.59	1.02	1.29	1.42
1	0.97	1.67	2.10	2.32
1	1.27	2.19	2.75	3.04
1	2.46	4.25	5.33	5.90
1	4.32	7.47	9.37	10.37

R515B

0.0	0.1	0.3	0.5
0.2	0.5	0.9	1.2
0.8	1.0	1.4	1.9
1.2	1.5	2.2	3.0
2.1	2.5	3.6	4.9
2.8	3.3	4.6	6.5
5.4	6.4	9.0	12.6
9.5	11.3	15.9	22.1

R515B

NRVH 6 v2	0.0	0.1	0.4	0.5
NRVH 10 v2	0.1	0.8	1.2	1.5
NRVH 12 v2	1.3	1.9	2.1	2.3
NRVH 16 v2	0.5	2.5	3.1	3.5
NRVH 19 v2	3.5	4.9	5.5	6.0
NRVH 22	5.6	6.5	7.2	7.8
NRVH 28	11.0	12.6	13.9	15.1
NRVH 35	19.3	22.1	24.5	26.6

R1233zd(E)

NRV 6 v2	0.4	1.4	3.3	4.5
NRV 10 v2	2.2	5.5	9.0	11.0
NRV 12 v2	8.1	9.7	13.7	16.8
NRV 16 v2	11.6	15.5	22.0	26.9
NRV 19 v2	21.1	25.3	35.7	43.7
NRV 22	27.6	33.0	46.7	57.2
NRV 28	53.6	64.1	90.7	111.1
NRV 35	94.3	112.7	159.4	195.2

R1233zd(E)

1	0.01	0.03	0.05	0.06
1	0.05	0.15	0.22	0.26
1	0.13	0.32	0.43	0.49
1	0.20	0.51	0.69	0.78
1	0.33	0.83	1.13	1.28
1	0.44	1.09	1.48	1.67
1	0.85	2.12	2.86	3.25
1	1.49	3.72	5.03	5.71

R1233zd(E)

0.0	0.1	0.2	0.3
0.1	0.3	0.6	0.7
0.5	0.6	0.9	1.1
0.7	1.0	1.4	1.8
1.4	1.6	2.2	2.9
1.8	2.1	2.9	3.8
3.5	4.1	5.6	7.5
6.1	7.2	9.9	13.1

R1233zd(E)

NRVH 6 v2	0.0	0.1	0.2	0.2
NRVH 10 v2	0.1	0.4	0.7	0.8
NRVH 12 v2	0.8	1.1	1.2	1.3
NRVH 16 v2	0.3	1.3	1.7	1.9
NRVH 19 v2	2.1	2.9	3.2	3.4
NRVH 22	3.4	3.8	4.2	4.4
NRVH 28	6.7	7.5	8.1	8.5
NRVH 35	11.7	13.1	14.2	15.0

R1234ze(E)

NRV 6 v2	0.3	1.1	2.8	3.7
NRV 10 v2	1.8	4.6	7.4	9.1
NRV 12 v2	6.7	8.0	11.3	13.9
NRV 16 v2	9.6	12.8	18.1	22.2
NRV 19 v2	17.4	20.8	29.5	36.1
NRV 22	22.8	27.3	38.5	47.2
NRV 28	44.3	52.9	74.8	91.6
NRV 35	77.8	93.0	131.5	161.1

R1234ze(E)

1	0.05	0.09	0.11	0.12
1	0.20	0.36	0.46	0.51
1	0.38	0.66	0.83	0.91
1	0.61	1.05	1.31	1.45
1	1.00	1.71	2.15	2.37
1	1.30	2.24	2.81	3.10
1	2.53	4.35	5.45	6.02
1	4.44	7.64	9.58	10.59

R1234ze(E)

0.0	0.1	0.3	0.5
0.2	0.6	0.9	1.3
0.8	1.0	1.4	1.9
1.2	1.6	2.2	3.1
2.2	2.6	3.6	5.1
2.8	3.4	4.8	6.6
5.5	6.6	9.2	12.8
9.7	11.6	16.2	22.6

R1234ze(E)

NRVH 6 v2	0.0	0.1	0.4	0.5
NRVH 10 v2	0.1	0.8	1.3	1.5
NRVH 12 v2	1.4	1.9	2.2	2.3
NRVH 16 v2	0.5	2.5	3.2	3.6
NRVH 19 v2	3.6	5.1	5.6	6.1
NRVH 22	5.8	6.6	7.3	8.0
NRVH 28	11.2	12.8	14.2	15.5
NRVH 35	19.7	22.6	25.0	27.2

Correction factors for liquid temperature t_l

t _l [°F]	15	32	50	60	70	80	86	95	105	115	125
R452A	0.68	0.74	0.83	0.88	0.95	1.02	1.12	1.23	1.37	1.54	1.79
R513A	0.71	0.77	0.85	0.90	0.96	1.02	1.10	1.18	1.29	1.41	1.57
R515B	0.72	0.78	0.86	0.90	0.96	1.02	1.09	1.17	1.26	1.37	1.51
R1233zd(E)	0.77	0.82	0.89	0.93	0.97	1.01	1.06	1.12	1.18	1.25	1.33
R1234ze(E)	0.72	0.78	0.86	0.91	0.96	1.02	1.09	1.17	1.26	1.36	1.49

Data sheet | Check valve, types NRV and NRVH

US units

Capacity

Liquid capacity [TR]

Type	Liquid capacity ¹⁾ at pressure drop across valve Δp [psi]			
	NRV			
	0.7	1	2	3

R290				
NRV 6 v2	0.4	1.5	3.7	5.0
NRV 10 v2	2.5	6.2	10.1	12.3
NRV 12 v2	9.1	10.9	15.4	18.8
NRV 16 v2	13.0	17.3	24.6	30.1
NRV 19 v2	23.6	28.2	39.9	48.9
NRV 22	30.9	36.9	52.2	63.9
NRV 28	59.9	71.6	101.3	124.1
NRV 35	105.3	125.9	178.1	218.1

R32				
NRV 6 v2	0.5	1.9	4.7	6.3
NRV 10 v2	3.1	7.7	12.6	15.4
NRV 12 v2	11.4	13.6	19.2	23.5
NRV 16 v2	16.2	21.6	30.7	37.6
NRV 19 v2	29.5	35.3	49.9	61.2
NRV 22	38.6	46.2	65.3	80.0
NRV 28	75.0	89.6	126.8	155.3
NRV 35	131.8	157.6	222.8	272.9

R452B				
NRV 6 v2	0.4	1.5	3.7	5.1
NRV 10 v2	2.5	6.2	10.1	12.4
NRV 12 v2	9.1	10.9	15.4	18.9
NRV 16 v2	13.0	17.3	24.7	30.2
NRV 19 v2	23.7	28.3	40.1	49.1
NRV 22	31.0	37.1	52.4	64.2
NRV 28	60.2	71.9	101.7	124.6
NRV 35	105.8	126.4	178.8	219.0

R455A				
NRV 6 v2	0.3	1.1	2.7	3.7
NRV 10 v2	1.8	4.5	7.3	9.0
NRV 12 v2	6.6	7.9	11.2	13.7
NRV 16 v2	9.4	12.5	17.8	21.9
NRV 19 v2	17.2	20.5	29.0	35.5
NRV 22	22.4	26.8	37.9	46.4
NRV 28	43.5	52.0	73.6	90.2
NRV 35	76.5	91.5	129.4	158.5

Suction vapour capacity [TR]

Pressure drop across valve Δp [psi]	Suction vapour capacity ¹⁾ at evaporating temperature t_e [°F]			
	NRV			
	-20	15	32	40

R290				
1	0.12	0.19	0.22	0.24
1	0.49	0.76	0.91	0.99
1	0.89	1.35	1.62	1.76
1	1.41	2.15	2.57	2.79
1	2.31	3.51	4.21	4.56
1	3.02	4.59	5.50	5.97
1	5.85	8.90	10.68	11.58
1	10.29	15.65	18.77	20.36

R32				
1	0.16	0.24	0.29	0.31
1	0.67	0.99	1.17	1.26
1	1.19	1.75	2.07	2.23
1	1.90	2.79	3.29	3.54
1	3.10	4.55	5.37	5.79
1	4.05	5.95	7.03	7.57
1	7.87	11.56	13.64	14.69
1	13.83	20.32	23.98	25.82

R452B				
1	0.13	0.20	0.24	0.26
1	0.55	0.82	0.98	1.06
1	0.97	1.45	1.73	1.87
1	1.55	2.31	2.75	2.97
1	2.53	3.78	4.50	4.86
1	3.31	4.95	5.88	6.35
1	6.43	9.60	11.41	12.33
1	11.30	16.87	20.06	21.67

R455A				
1	0.08	0.13	0.16	0.18
1	0.33	0.53	0.65	0.71
1	0.60	0.95	1.16	1.27
1	0.95	1.51	1.84	2.01
1	1.56	2.47	3.01	3.29
1	2.03	3.23	3.94	4.30
1	3.95	6.27	7.65	8.36
1	6.94	11.02	13.44	14.69

Hot gas capacity [TR]

Type	Hot gas capacity ¹⁾ at pressure drop across valve Δp [psi]			
	NRV			
	0.7	1	2	4

R290				
0.1	0.2	0.6	0.9	
0.4	1.0	1.6	2.3	
1.5	1.8	2.5	3.5	
2.1	2.8	4.0	5.6	
3.9	4.6	6.5	9.1	
5.1	6.1	8.5	12.0	
9.8	11.8	16.6	23.2	
17.3	20.7	29.1	40.8	

R32				
0.1	0.3	0.8	1.2	
0.5	1.3	2.2	3.0	
1.9	2.3	3.3	4.6	
2.8	3.7	5.3	7.4	
5.1	6.1	8.5	12.0	
6.6	7.9	11.2	15.7	
12.9	15.4	21.7	30.5	
22.6	27.0	38.1	53.7	

R452B				
0.1	0.3	0.7	1.0	
0.4	1.1	1.8	2.6	
1.6	2.0	2.8	3.9	
2.3	3.1	4.4	6.3	
4.3	5.1	7.2	10.2	
5.6	6.7	9.4	13.3	
10.9	13.0	18.3	25.8	
19.1	22.8	32.2	45.3	

R455A				
0.1	0.2	0.5	0.8	
0.3	0.9	1.4	2.0	
1.3	1.5	2.2	3.0	
1.8	2.4	3.4	4.8	
3.3	4.0	5.6	7.9	
4.3	5.2	7.3	10.3	
8.4	10.1	14.2	20.0	
14.8	17.7	24.9	35.1	

Hot gas capacity [TR]

Type	Hot gas capacity ¹⁾ at pressure drop across valve Δp [psi]			
	NRVH			
	3	4	5	6

R290				
NRVH 6 v2	0.1	0.2	0.7	0.9
NRVH 10 v2	0.2	1.5	2.3	2.8
NRVH 12 v2	2.4	3.5	3.9	4.3
NRVH 16 v2	1.0	4.6	5.8	6.6
NRVH 19 v2	6.4	9.1	10.2	11.1
NRVH 22	10.4	12.0	13.3	14.5
NRVH 28	20.2	23.2	25.9	28.2
NRVH 35	35.5	40.8	45.4	49.6

R32				
NRVH 6 v2	0.1	0.3	1.0	1.2
NRVH 10 v2	0.2	1.9	3.1	3.7
NRVH 12 v2	3.2	4.6	5.2	5.6
NRVH 16 v2	1.3	6.1	7.6	8.7
NRVH 19 v2	8.5	12.0	13.4	14.7
NRVH 22	13.7	15.7	17.6	19.2
NRVH 28	26.5	30.5	34.1	37.3
NRVH 35	46.6	53.7	59.9	65.5

R452B				
NRVH 6 v2	0.1	0.2	0.8	1.0
NRVH 10 v2	0.2	1.6	2.6	3.1
NRVH 12 v2	2.7	3.9	4.4	4.8
NRVH 16 v2	1.1	5.1	6.5	7.4
NRVH 19 v2	7.2	10.2	11.3	12.4
NRVH 22	11.5	13.3	14.8	16.2
NRVH 28	22.4	25.8	28.8	31.4
NRVH 35	39.3	45.3	50.5	55.2

R455A				
NRVH 6 v2	0.0	0.2	0.6	0.8
NRVH 10 v2	0.1	1.3	2.0	2.4
NRVH 12 v2	2.1	3.0	3.4	3.7
NRVH 16 v2	0.9	4.0	5.0	5.7
NRVH 19 v2	5.5	7.9	8.8	9.6
NRVH 22	8.9	10.3	11.5	12.5
NRVH 28	17.3	20.0	22.3	24.3
NRVH 35	30.5	35.1	39.1	42.7

1) Rated capacities are based on:

-Evaporating temperature, $t_e = 14^\circ\text{F}$

-Condensing temperature, $t_c = 86^\circ\text{F}$

-Subcooling $t_{\text{sub}} = 9^\circ\text{F}$

-Superheat $t_{\text{sh}} = 0^\circ\text{F}$

-Discharge temperature, $t_d = 176^\circ\text{F}$ ahead of the valve.

The table values refer to the evaporator capacity.

Correction factors

When selecting the evaporator capacity is to be multiplied by a correction factor depending on the liquid temperature t_l ahead of the valve/the evaporator. The corrected capacity can then be found from the table.

System capacity = Correction factor × Table capacity

Correction factors for liquid temperature t_l

t_l [°F]	15	32	50	60	70	80	86	95	105	115	125
R290	0.74	0.79	0.86	0.91	0.96	1.02	1.08	1.16	1.25	1.35	1.48
R32	0.76	0.82	0.88	0.92	0.97	1.02	1.07	1.14	1.22	1.31	1.42
R452B	0.74	0.80	0.86	0.91	0.96	1.02	1.08	1.16	1.25	1.36	1.50
R455A	0.70	0.77	0.84	0.90	0.95	1.02	1.10	1.19	1.30	1.44	1.61

Data sheet | Check valve, types NRV and NRHV

Capacity

US units

Liquid capacity [TR]

Type	Liquid capacity ¹⁾ at pressure drop across valve Δp [psi]			
	NRV			
	0.7	1	2	3

R454A

NRV 6 v2	0.3	1.2	3.0	4.0
NRV 10 v2	2.0	4.9	8.0	9.8
NRV 12 v2	7.2	8.6	12.2	14.9
NRV 16 v2	10.3	13.7	19.5	23.8
NRV 19 v2	18.7	22.4	31.6	38.7
NRV 22	24.5	29.3	41.4	50.7
NRV 28	47.5	56.8	80.3	98.4
NRV 35	83.5	99.8	141.1	172.9

R454B

NRV 6 v2	0.4	1.6	3.8	5.1
NRV 10 v2	2.5	6.3	10.2	12.6
NRV 12 v2	9.2	11.1	15.6	19.1
NRV 16 v2	13.2	17.6	25.0	30.6
NRV 19 v2	24.0	28.7	40.6	49.8
NRV 22	31.4	37.6	53.2	65.1
NRV 28	61.0	73.0	103.2	126.4
NRV 35	107.3	128.2	181.3	222.1

R454C

NRV 6 v2	0.3	1.1	2.7	3.6
NRV 10 v2	1.8	4.4	7.2	8.8
NRV 12 v2	6.5	7.8	11.0	13.4
NRV 16 v2	9.3	12.3	17.6	21.5
NRV 19 v2	16.9	20.2	28.5	35.0
NRV 22	22.1	26.4	37.3	45.7
NRV 28	42.9	51.2	72.4	88.7
NRV 35	75.3	90.0	127.3	155.9

R516A

NRV 6 v2	0.3	1.1	2.6	3.5
NRV 10 v2	1.7	4.3	7.0	8.6
NRV 12 v2	6.4	7.6	10.8	13.2
NRV 16 v2	9.1	12.1	17.2	21.1
NRV 19 v2	16.6	19.8	28.0	34.3
NRV 22	21.7	25.9	36.6	44.8
NRV 28	42.0	50.2	71.1	87.0
NRV 35	73.9	88.3	124.9	153.0

Suction vapour capacity [TR]

Pressure drop across valve Δp [psi]	Suction vapour capacity ¹⁾ at evaporating temperature t _e [°F]			
	NRV			
	-20	15	32	40

R454A

1	0.09	0.15	0.18	0.20
1	0.38	0.60	0.73	0.80
1	0.69	1.07	1.30	1.42
1	1.10	1.71	2.07	2.25
1	1.79	2.79	3.38	3.68
1	2.34	3.65	4.42	4.81
1	4.55	7.09	8.58	9.34
1	7.99	12.45	15.07	16.42

R454B

1	0.13	0.20	0.24	0.26
1	0.55	0.82	0.98	1.06
1	0.98	1.46	1.73	1.87
1	1.56	2.32	2.76	2.98
1	2.54	3.79	4.51	4.87
1	3.32	4.96	5.90	6.37
1	6.45	9.63	11.45	12.37
1	11.34	16.93	20.12	21.73

R454C

1	0.08	0.13	0.15	0.17
1	0.32	0.51	0.63	0.69
1	0.58	0.92	1.12	1.23
1	0.92	1.46	1.78	1.95
1	1.50	2.39	2.91	3.19
1	1.96	3.12	3.81	4.17
1	3.80	6.06	7.40	8.09
1	6.68	10.64	13.00	14.22

R516A

1	0.06	0.11	0.13	0.14
1	0.26	0.43	0.54	0.59
1	0.48	0.78	0.96	1.06
1	0.76	1.24	1.53	1.68
1	1.24	2.03	2.50	2.74
1	1.62	2.65	3.27	3.59
1	3.14	5.14	6.34	6.96
1	5.52	9.04	11.15	12.24

Hot gas capacity [TR]

Hot gas capacity ¹⁾ at pressure drop across valve Δp [psi]	NRV			
	NRV			
	0.7	1	2	4

R454A

0.1	0.2	0.5	0.8
0.4	0.9	1.5	2.1
1.3	1.6	2.2	3.1
1.9	2.5	3.6	5.0
3.5	4.1	5.8	8.2
4.5	5.4	7.6	10.7
8.8	10.5	14.8	20.7
15.4	18.4	25.9	36.5

R454B

0.1	0.3	0.7	1.1
0.5	1.1	1.8	2.6
1.7	2.0	2.8	3.9
2.4	3.1	4.5	6.3
4.3	5.1	7.3	10.2
5.6	6.7	9.5	13.4
10.9	13.1	18.4	26.0
19.2	23.0	32.4	45.6

R454C

0.1	0.2	0.5	0.7
0.3	0.8	1.3	1.8
1.2	1.4	2.0	2.8
1.7	2.2	3.2	4.5
3.1	3.7	5.2	7.3
4.0	4.8	6.8	9.5
7.8	9.3	13.1	18.5
13.7	16.4	23.1	32.4

R516A

0.0	0.2	0.4	0.6
0.3	0.6	1.0	1.4
0.9	1.1	1.6	2.2
1.3	1.8	2.5	3.5
2.4	2.9	4.0	5.7
3.2	3.8	5.3	7.4
6.1	7.3	10.3	14.4
10.8	12.8	18.1	25.3

Hot gas capacity [TR]

Type	Hot gas capacity ¹⁾ at pressure drop across valve Δp [psi]			
	NRHV			
	3	4	5	6

R454A

NRVH 6 v2	0.0	0.2	0.7	0.8
NRVH 10 v2	0.2	1.3	2.1	2.5
NRVH 12 v2	2.2	3.1	3.5	3.8
NRVH 16 v2	0.9	4.1	5.2	5.9
NRVH 19 v2	5.8	8.2	9.1	10.0
NRVH 22	9.3	10.7	11.9	13.0
NRVH 28	18.0	20.7	23.1	25.3
NRVH 35	31.7	36.5	40.6	44.4

R454B

NRVH 6 v2	0.1	0.2	0.8	1.0
NRVH 10 v2	0.2	1.7	2.6	3.1
NRVH 12 v2	2.7	3.9	4.4	4.8
NRVH 16 v2	1.1	5.2	6.5	7.4
NRVH 19 v2	7.2	10.2	11.4	12.5
NRVH 22	11.6	13.4	14.9	16.3
NRVH 28	22.5	26.0	28.9	31.6
NRVH 35	39.6	45.6	50.9	55.6

R454C

NRVH 6 v2	0.0	0.2	0.6	0.7
NRVH 10 v2	0.1	1.2	1.9	2.2
NRVH 12 v2	1.9	2.8	3.1	3.4
NRVH 16 v2	0.8	3.7	4.6	5.3
NRVH 19 v2	5.1	7.3	8.1	8.8
NRVH 22	8.3	9.5	10.6	11.6
NRVH 28	16.0	18.5	20.6	22.5
NRVH 35	28.2	32.4	36.2	39.5

R516A

NRVH 6 v2	0.0	0.1	0.5	0.6
NRVH 10 v2	0.1	0.9	1.4	1.7
NRVH 12 v2	1.5	2.2	2.4	2.6
NRVH 16 v2	0.6	2.8	3.6	4.1
NRVH 19 v2	4.0	5.7	6.3	6.9
NRVH 22	6.4	7.4	8.2	9.0
NRVH 28	12.5	14.4	16.0	17.4
NRVH 35	22.0	25.3	28.1	30.6

¹⁾ Rated capacities are based on:

-Evaporating temperature, t_e = 14 °F

-Condensing temperature, t_c = 86 °F

-Subcooling t_{sub} = 9 °F

-Superheat t_{sh} = 0 °F

-Discharge temperature, t_d = 176 °F ahead of the valve.

The table values refer to the evaporator capacity.

Correction factors

When selecting the evaporator capacity is to be multiplied by a correction factor depending on the liquid temperature t_l ahead of the valve/the evaporator. The corrected capacity can then be found from the table.

System capacity = Correction factor × Table capacity

Correction factors for liquid temperature t_l

t _l [°F]	15	32	50	60	70	80	86	95	105	115	125
R454A	0.71	0.77	0.85	0.90	0.96	1.02	1.09	1.18	1.29	1.42	1.58
R454B	0.74	0.80	0.87	0.91	0.96	1.02	1.08	1.16	1.25	1.35	1.49
R454C	0.70	0.77	0.84	0.90	0.95	1.02	1.10	1.19	1.30	1.44	1.61
R516A	0.71	0.77	0.85	0.90	0.96	1.02	1.09	1.18	1.28	1.40	1.55

Data sheet | Check valve, types NRV and NRHV

US units

Capacity

Liquid capacity [TR]

Type	Liquid capacity ¹⁾ at pressure drop across valve Δp [psi]			
	NRV			
	0.7	1	2	3

R600				
NRV 6 v2	0.4	1.7	4.2	5.7
NRV 10 v2	2.8	7.0	11.3	13.9
NRV 12 v2	10.2	12.2	17.3	21.2
NRV 16 v2	14.6	19.4	27.7	33.9
NRV 19 v2	26.6	31.8	44.9	55.0
NRV 22	34.8	41.5	58.8	72.0
NRV 28	67.5	80.7	114.1	139.7
NRV 35	118.6	141.8	200.5	245.5

R600a				
NRV 6 v2	0.4	1.5	3.7	5.0
NRV 10 v2	2.5	6.2	10.0	12.3
NRV 12 v2	9.1	10.8	15.3	18.8
NRV 16 v2	12.9	17.2	24.5	30.0
NRV 19 v2	23.6	28.2	39.9	48.8
NRV 22	30.8	36.9	52.1	63.8
NRV 28	59.9	71.6	101.2	123.9
NRV 35	105.2	125.8	177.8	217.8

R1234yf				
NRV 6 v2	0.2	0.9	2.3	3.1
NRV 10 v2	1.5	3.8	6.2	7.6
NRV 12 v2	5.6	6.7	9.4	11.6
NRV 16 v2	8.0	10.6	15.1	18.5
NRV 19 v2	14.5	17.3	24.5	30.0
NRV 22	19.0	22.7	32.1	39.3
NRV 28	36.8	44.0	62.3	76.3
NRV 35	64.8	77.4	109.4	134.0

R1270				
NRV 6 v2	0.4	1.6	3.9	5.2
NRV 10 v2	2.6	6.4	10.4	12.7
NRV 12 v2	9.4	11.2	15.9	19.4
NRV 16 v2	13.4	17.9	25.4	31.1
NRV 19 v2	24.4	29.2	41.3	50.5
NRV 22	31.9	38.1	53.9	66.1
NRV 28	62.0	74.0	104.7	128.3
NRV 35	108.9	130.1	184.1	225.4

Suction vapour capacity [TR]

Pressure drop across valve Δp [psi]	Suction vapour capacity ¹⁾ at evaporating temperature t _e [°F]			
	NRV			
	-20	15	32	40

R600				
1	0.04	0.08	0.11	0.12
1	0.17	0.35	0.46	0.51
1	0.37	0.67	0.85	0.94
1	0.59	1.06	1.35	1.50
1	0.96	1.74	2.20	2.44
1	1.26	2.28	2.88	3.20
1	2.44	4.42	5.60	6.21
1	4.29	7.77	9.84	10.91

R600a				
1	0.05	0.10	0.13	0.14
1	0.23	0.42	0.54	0.59
1	0.46	0.78	0.97	1.07
1	0.73	1.24	1.54	1.70
1	1.19	2.03	2.52	2.78
1	1.56	2.65	3.30	3.63
1	3.03	5.14	6.40	7.05
1	5.32	9.04	11.25	12.40

R1234yf				
1	0.06	0.10	0.12	0.13
1	0.23	0.40	0.49	0.54
1	0.43	0.71	0.88	0.97
1	0.68	1.13	1.40	1.54
1	1.12	1.85	2.29	2.52
1	1.46	2.41	2.99	3.30
1	2.83	4.69	5.81	6.40
1	4.98	8.24	10.22	11.24

R1270				
1	0.14	0.21	0.25	0.27
1	0.56	0.85	1.01	1.09
1	1.01	1.51	1.79	1.94
1	1.61	2.40	2.85	3.08
1	2.63	3.92	4.66	5.04
1	3.44	5.13	6.09	6.59
1	6.68	9.95	11.83	12.78
1	11.74	17.49	20.79	22.47

Hot gas capacity [TR]

Hot gas capacity ¹⁾ at pressure drop across valve Δp [psi]	NRV			
	NRV			
	0.7	1	2	4

R600				
0.0	0.1	0.4	0.5	
0.2	0.6	1.0	1.3	
0.9	1.1	1.5	2.0	
1.3	1.7	2.4	3.2	
2.3	2.8	3.9	5.3	
3.0	3.6	5.0	6.9	
5.9	7.0	9.8	13.4	
10.4	12.4	17.2	23.6	

R600a				
0.0	0.2	0.4	0.6	
0.3	0.7	1.1	1.5	
1.0	1.2	1.6	2.2	
1.4	1.9	2.6	3.6	
2.5	3.0	4.2	5.8	
3.3	4.0	5.5	7.6	
6.4	7.7	10.7	14.8	
11.3	13.5	18.9	26.1	

R1234yf				
0.0	0.1	0.3	0.5	
0.2	0.6	0.9	1.3	
0.8	1.0	1.4	2.0	
1.2	1.6	2.3	3.2	
2.2	2.6	3.7	5.1	
2.9	3.4	4.8	6.7	
5.5	6.6	9.3	13.0	
9.7	11.6	16.4	22.9	

R1270				
0.1	0.3	0.7	1.0	
0.4	1.1	1.8	2.5	
1.6	2.0	2.8	3.9	
2.3	3.1	4.4	6.2	
4.3	5.1	7.2	10.1	
5.6	6.7	9.4	13.2	
10.8	12.9	18.2	25.6	
19.0	22.7	32.0	44.9	

Hot gas capacity [TR]

Type	Hot gas capacity ¹⁾ at pressure drop across valve Δp [psi]			
	NRVH			
	3	4	5	6

R600				
NRVH 6 v2	0.0	0.1	0.4	0.5
NRVH 10 v2	0.1	0.8	1.3	1.6
NRVH 12 v2	1.4	2.0	2.2	2.4
NRVH 16 v2	0.6	2.5	3.2	3.7
NRVH 19 v2	3.7	5.3	5.8	6.2
NRVH 22	6.1	6.9	7.6	8.2
NRVH 28	11.8	13.4	14.7	15.9
NRVH 35	20.7	23.6	25.9	27.9

R600a				
NRVH 6 v2	0.0	0.1	0.4	0.6
NRVH 10 v2	0.1	0.9	1.5	1.8
NRVH 12 v2	1.6	2.2	2.5	2.7
NRVH 16 v2	0.6	2.9	3.6	4.1
NRVH 19 v2	4.1	5.8	6.5	7.0
NRVH 22	6.7	7.6	8.4	9.1
NRVH 28	13.0	14.8	16.4	17.8
NRVH 35	22.8	26.1	28.8	31.2

R1234yf				
NRVH 6 v2	0.0	0.1	0.4	0.5
NRVH 10 v2	0.1	0.8	1.3	1.6
NRVH 12 v2	1.4	2.0	2.2	2.4
NRVH 16 v2	0.6	2.6	3.2	3.7
NRVH 19 v2	3.6	5.1	5.7	6.2
NRVH 22	5.8	6.7	7.4	8.1
NRVH 28	11.3	13.0	14.5	15.7
NRVH 35	19.9	22.9	25.4	27.7

R1270				
NRVH 6 v2	0.1	0.2	0.8	1.0
NRVH 10 v2	0.2	1.6	2.6	3.1
NRVH 12 v2	2.7	3.9	4.3	4.7
NRVH 16 v2	1.1	5.1	6.4	7.3
NRVH 19 v2	7.1	10.1	11.2	12.3
NRVH 22	11.4	13.2	14.7	16.0
NRVH 28	22.2	25.6	28.5	31.1
NRVH 35	39.0	44.9	50.1	54.7

¹⁾ Rated capacities are based on:
 -Evaporating temperature, t_e = 14 °F
 -Condensing temperature, t_c = 86 °F
 -Subcooling t_{sub} = 9 °F
 -Superheat t_{sh} = 0 °F
 -Discharge temperature, t_d = 176 °F ahead of
 the valve.
 The table values refer to the evaporator
 capacity.

Correction factors

When selecting the evaporator capacity is to be multiplied by a correction factor depending on the liquid temperature t_l ahead of the valve/the evaporator. The corrected capacity can then be found from the table.

$$\text{System capacity} \cdot \text{Correction factor} = \text{Table capacity}$$

Correction factors for liquid temperature t_l

t _l [°F]	15	32	50	60	70	80	86	95	105	115	125
R600	0.77	0.82	0.88	0.92	0.97	1.02	1.07	1.13	1.20	1.27	1.36
R600a	0.75	0.81	0.87	0.92	0.96	1.02	1.08	1.14	1.22	1.31	1.41
R1234yf	0.69	0.76	0.84	0.89	0.95	1.02	1.10	1.20	1.32	1.46	1.63
R1270	0.74	0.80	0.87	0.91	0.96	1.02	1.08	1.16	1.24	1.35	1.47

Note:
 - For capacity calculation of other refrigerants, please contact Danfoss.

Data sheet | Check valve, types NRV and NRVH

Dimensions and weights

NRV 6 - 19

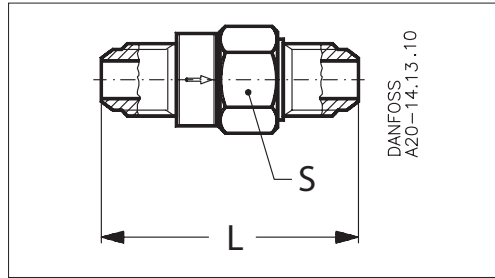

Flare straightway connection - SI Units

Type	Size		L [mm]	Spanner flats S [mm]	Net weight [kg]
	[in]	[mm]			
NRV 6	1/4	6	55	19	0.07
NRV 10	3/8	10	60	19	0.08
NRV 12	1/2	12	70	24	0.14
NRV 16	5/8	16	81	28	0.20
NRV 19	3/4	19	95	34	0.34

Flare straightway connection - US Units

Type	Size	L [in]	Spanner flats S [in]	Net weight [lb]
	[in]			
NRV 6	1/4	2.17	0.75	0.15
NRV 10	3/8	2.36	0.75	0.19
NRV 12	1/2	2.76	0.94	0.30
NRV 16	5/8	3.19	1.10	0.45
NRV 19	3/4	3.74	1.34	0.75

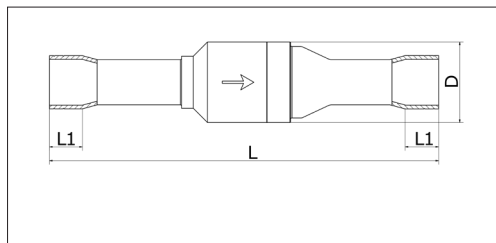
Dimensions and weights
NRV 6s - 19s / NRVH 6s - 19s

Solder straightway connection - SI Units

Type	Size		L [mm]	L ₁ [mm]	øD [mm]	Net weight [kg]
	[in]	[mm]				
NRV/NRVH 6s v2	1/4	6	92	7	18	0.05
NRV/NRVH 6s v2 ¹⁾	3/8	10	95	9	18	0.06
NRV/NRVH 10s v2	3/8	10	109	9	18	0.05
NRV/NRVH 10s v2 ¹⁾	1/2	12	109	10	18	0.06
NRV/NRVH 12s v2	1/2	12	131	10	22	0.09
NRV/NRVH 12s v2 ¹⁾	5/8	16	131	12	22	0.09
NRV/NRVH 16s v2	5/8	16	139	12	28	0.16
NRV/NRVH 16s v2 ¹⁾	–	18	139	14	28	0.17
NRV/NRVH 19s v2	–	18	165	14	34	0.27
NRV/NRVH 16s v2 ¹⁾	3/4	19	139	14	28	0.17
NRV/NRVH 19s v2	3/4	19	165	14	34	0.28
NRV/NRVH 19s v2 ¹⁾	7/8	22	165	17	34	0.28

Solder straightway connection - US Units

Type	Size	L [in]	L ₁ [in]	øD [in]	Net weight [lb]
	[in]				
NRV/NRVH 6s v2	1/4	3.62	0.28	0.71	0.11
NRV/NRVH 6s v2 ¹⁾	3/8	3.74	0.35	0.71	0.13
NRV/NRVH 10s v2	3/8	4.29	0.35	0.71	0.11
NRV/NRVH 10s v2 ¹⁾	1/2	4.29	0.39	0.71	0.13
NRV/NRVH 12s v2	1/2	5.16	0.39	0.87	0.20
NRV/NRVH 12s v2 ¹⁾	5/8	5.16	0.47	0.87	0.20
NRV/NRVH 16s v2	5/8	5.47	0.47	1.10	0.35
NRV/NRVH 16s v2 ¹⁾	3/4	5.47	0.55	1.10	0.38
NRV/NRVH 19s v2	3/4	6.50	0.55	1.34	0.62
NRV/NRVH 19s v2 ¹⁾	7/8	6.50	0.67	1.34	0.62

¹⁾ Oversize connections.

**Dimensions
and weights**

NRV 22s - 35s / NRVH 22s - 35s

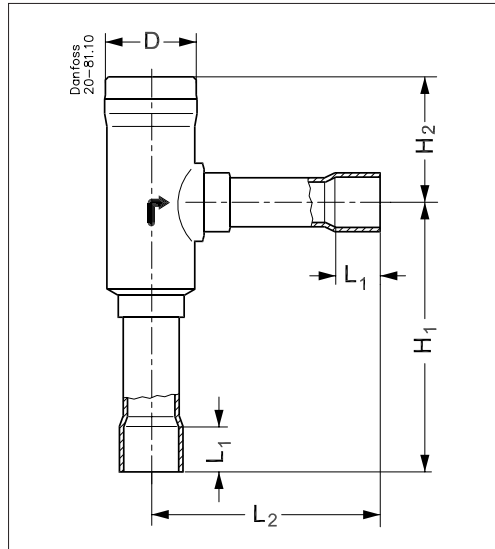

Solder angleway connection - SI Units

Type	Size		H ₁ [mm]	H ₂ [mm]	L ₁ [mm]	L ₂ [mm]	øD [mm]	Net weight [Kg]
	[in]	[mm]						
NRV/NRVH 22s	7/8	22	94	48	17	87	37	0.58
NRV/NRVH 22s ¹⁾	1 1/8	28	94	48	22	87	37	0.61
NRV/NRVH 28s	1 1/8	28	141	67	20	123	49	1.33
NRV/NRVH 28s ¹⁾	1 3/8	35	141	67	25	123	49	1.47
NRV/NRVH 35s	1 3/8	35	141	67	25	123	49	1.40
NRV/NRVH 35s ¹⁾	1 5/8	42	141	67	29	123	49	1.38

Solder angleway connection - US Units

Type	Size	H ₁ [in]	H ₂ [in]	L ₁ [in]	L ₂ [in]	øD [in]	Net weight [lb]
	[in]						
NRV/NRVH 22s	7/8	3.70	1.89	0.67	3.43	1.46	1.28
NRV/NRVH 22s ¹⁾	1 1/8	3.70	1.89	0.87	3.43	1.46	1.35
NRV/NRVH 28s	1 1/8	5.55	2.64	0.79	4.84	1.93	2.93
NRV/NRVH 28s ¹⁾	1 3/8	5.55	2.64	0.98	4.84	1.93	3.26
NRV/NRVH 35s	1 3/8	5.55	2.64	0.98	4.84	1.93	3.08
NRV/NRVH 35s ¹⁾	1 5/8	5.55	2.64	1.14	4.84	1.93	3.06

¹⁾ Oversize connections.