

## Data Sheet

Valve station  
Type **ICF 15, ICF 20, ICF 25,  
ICF 50 and ICF 65**

ICF valve station incorporates several functions in one housing, which can replace a series of conventional mechanical, electro-mechanical and electronically operated valves

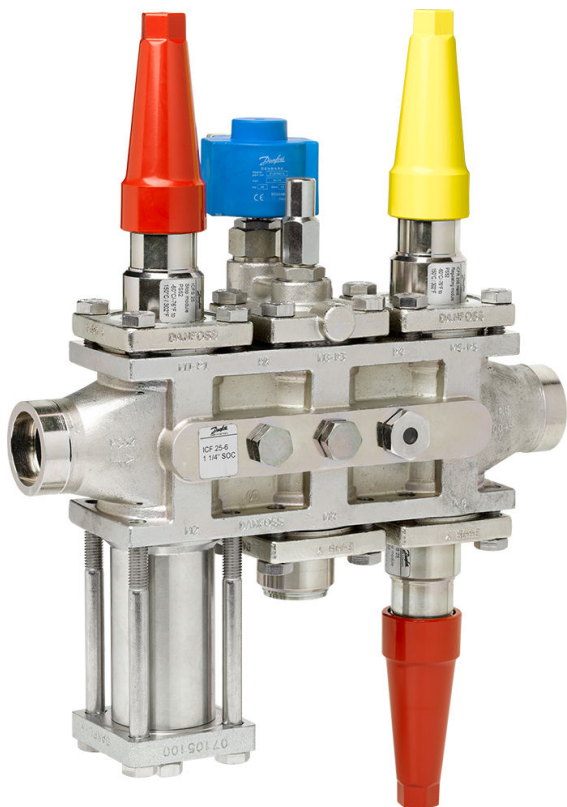

Based on advanced technology the ICF valve station incorporates several functions in one housing, which can replace a series of conventional mechanical, electro-mechanical and electronically operated valves.

This valve station not only provides a number of advantages in the design phase of a refrigeration plant but also in the installation, service and maintenance.

The ICF valve stations are designed for low and high pressure refrigerants and can be used in pumped liquid lines, liquid injection lines, liquid drain lines and hot gas lines.

Supplied as a complete assembly, it is fully tested at high pressure and its functions are tested under factory controlled conditions.

One code number equals one application solution.

## Features

- Designed for industrial refrigeration applications for a maximum working pressure of 52 bar/754 psig. (For ICF 20-2 and ICF with ICFD defrost module; see Technical Data, Pressure [Page 17](#))
- Applicable to HCFC, non flammable HFC, R717 (Ammonia) and R744 (CO<sub>2</sub>). The use of ICF valve stations with flammable hydrocarbons is not recommended
- Direct weld connections (No leaks through flanges)
- Connection types include butt weld and socket weld
- Low temperature steel housing
- Low weight and compact design
- V-port regulating cones on the control modules ensure optimum regulating accuracy particularly at part load
- Modular Concept:
  - Each housing is available with several different connection types and sizes. Valve service is performed by replacing the function module
- Side ports for the connection of pressure gauges, transmitters, sight glasses, service valve etc.
- UL approved

## Applications

### Application overview

#### Application overview (generic configuration - connection type and size excluded)

**Table 1: Liquid feed**

Application #		Sequence of functions					
		M1	M2	M3	M4	M5	M6
1	Liquid feed (No hotgas defrost)	Shut-off	Strainer	Solenoid	Man Open	Regul.	Shut-off
2	Liquid feed	Shut-off	Strainer	Solenoid	Man Open	Regul.	Stop & check
3	Liquid feed	Shut-off	Strainer	Solenoid	Check	Regul.	Shut-off
10	Liquid feed (No hotgas defrost)	Shut-off	Strainer	Solenoid	Regul.		
15	Liquid feed w. external Conn.	Shut-off	Strainer	Solenoid	Check	Welding	Regul.

**Table 2: Solenoid common**

Application #		Sequence of functions					
		M1	M2	M3	M4	M5	M6
4	Solenoid - Liquid & Hot gas lines	Shut-off	Strainer	Solenoid	Man Open	Shut-off	
8	Solenoid - Liquid & Hot gas lines	Shut-off	Strainer	Solenoid	Man Open		
121	Solenoid - generic	Solenoid	Man Open				

**Table 3: Liquid injection**

Application #		Sequence of functions					
		M1	M2	M3	M4	M5	M6
5	Liquid injection (expansion)	Shut-off	Strainer	Solenoid	Man Open	Motor	Shut-off
12	Liquid injection (expansion) PWM	Shut-off	Strainer	El. Exp.	Shut-off		
14	Liquid injection (expansion)	Shut-off	Strainer	Motor	Shut-off		

**Table 4: Hot gas defrost**

Application #		Sequence of functions			
		M1	M2	M3	M4
9	Hot gas defrost	Shut-off	Strainer	Solenoid	Shut-off

**Table 5: Hot gas defrost (ICF 50 only)**

Application #		Sequence of functions			
		M1	M2	M3	M4
47	Hot gas defrost - On/Off 2-step solenoid	Shut-off	Strainer option <sup>(1)</sup>	Solenoid	Shut-off
48	Hot gas defrost - On/Off 2-step solenoid + manual Regulating	Shut-off	Strainer option <sup>(1)</sup>	Solenoid	Regul.

<sup>(1)</sup> ICF 50 only

**Table 6: Solenoid multiple evaporators**

Application #		Sequence of functions			
		M1	M2	M3	M4
11	Solenoid - Multiple evaporators	Shut-off	Strainer	Solenoid	Check
18	Solenoid - Multiple evaporators	Shut-off	Strainer	Solenoid	Stop & check

**Table 7: Liquid PWM**

Application #		Sequence of functions			
		M1	M2	M3	M4
13	Liquid injection & liquid feed PWM	Shut-off	Strainer	El. Exp.	Stop & check

**Table 8: Return line (ICF 50 and ICF 65 only)**

Application #		Sequence of functions			
		M1	M2	M3	M4
41	ON/OFF 2-step solenoid	Shut-off	Strainer option <sup>(1)</sup>	Solenoid	Shut-off
42	Pressure (temperature) Mechanical control	Shut-off	Strainer option <sup>(1)</sup>	ICS options <sup>(2)</sup>	Shut-off
43	Pressure (temperature) Electronic control	Shut-off	Strainer option <sup>(1)</sup>	Motor	Shut-off

## Valve station, type ICF 15, ICF 20, ICF 25, ICF 50 and ICF 65

Application #		Sequence of functions			
		M1	M2	M3	M4
44	ON/OFF 2-step solenoid + Manuel Regulating	Shut-off	Strainer option <sup>(1)</sup>	Solenoid	Regul.
45	Pressure (temperature) Mechanical control + Manuel Regulating	Shut-off	Strainer option <sup>(1)</sup>	ICS options <sup>(2)</sup>	Regul.
46	Pressure (temperature) Electronic control + Manuel Regulating	Shut-off	Strainer option <sup>(1)</sup>	Motor	Regul.

<sup>(1)</sup> ICF 50 only

<sup>(2)</sup> ICS typical options: On/Off solenoid, Pressure or Temperature control (see ICS data sheet)

**Table 9: Miscellaneous**

Application #	Sequence of functions			
	M1	M2	M3	M4
90	Multipurpose configurations			

**Table 10: Defrost drain line**

Application #		Sequence of functions			
		M1	M2	M3	M4
102D1	Liquid drain M2 with solenoid - 2 shut-off	Shut-off	Liquid drain (ammonia)	Solenoid	Shut-off
102D2	Liquid drain M2 with solenoid - 2 shut-off	Shut-off	Liquid drain (CO <sub>2</sub> )	Solenoid	Shut-off
103D1	Liquid drain M4 with solenoid - 1 shut-off	Shut-off	Solenoid	Liquid drain (ammonia)	
104D1	Liquid drain M4 with strainer and solenoid - 1 shut-off	Shut-off	Strainer	Solenoid	Liquid drain (ammonia)
104D2	Liquid drain M4 with strainer and solenoid - 1 shut-off	Shut-off	Strainer	Solenoid	Liquid drain (CO <sub>2</sub> )
105D1	Liquid drain M2 with solenoid - 1 shut-off	Shut-off	Liquid drain (ammonia)	Solenoid	Shut-off
105D2	Liquid drain M2 with solenoid - 1 shut-off	Shut-off	Liquid drain (CO <sub>2</sub> )	Solenoid	
106D1	Liquid drain M2 with solenoid and manual opener - 1 shut off	Shut-off	Liquid drain (ammonia)	Solenoid	Man Open
107D1	Liquid drain M2 with solenoid and manual opener - 2 shut off	Shut-off	Liquid drain (ammonia)	Solenoid	Man Open
108D1	Liquid drain M2 without solenoid - 2 shut off	Shut-off	Liquid drain (ammonia)	Shut-off	
109D2	Liquid drain M2	Shut-off	Liquid drain (CO <sub>2</sub> )	Solenoid	Stop & check
110D1P1	Liquid drain M2, loaded check valve without solenoid - 2 shut-off	Shut-off	Liquid drain (ammonia)	Loaded check	Shut-off

## Example of application

### Liquid feed line

A valve combination for a flooded evaporator operating on/off from a thermostat and with electric defrost is required. Manual override of the solenoid valve is requested. Common ICF configurations for this kind of application is shown here:

**Figure 1: ICF configurations**

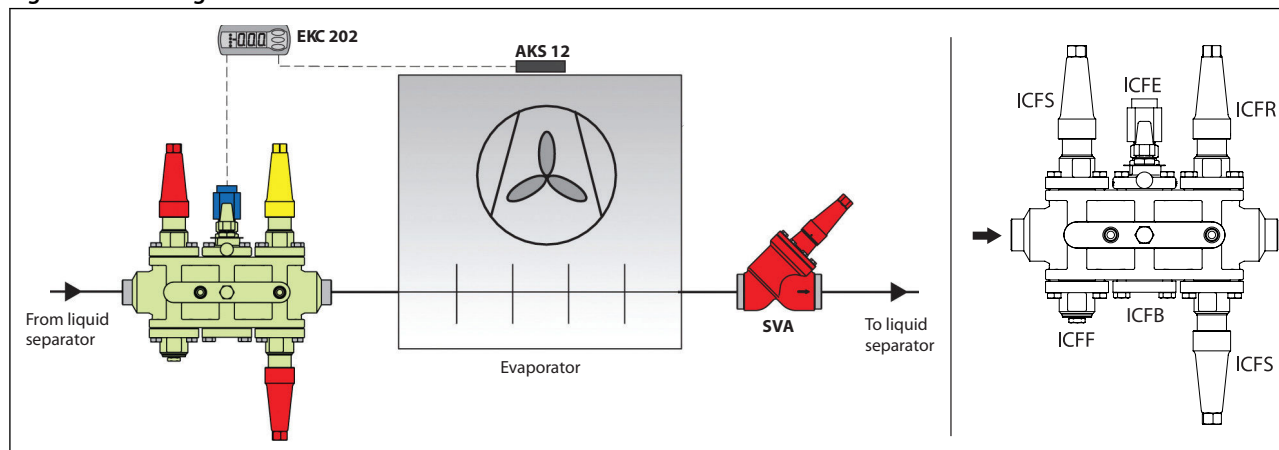



## Valve station, type ICF 15, ICF 20, ICF 25, ICF 50 and ICF 65

A valve combination for compressor liquid injection with electronic injection valve is required. It is required to have a solenoid valve in front of the control valve.

**Figure 4: Valve combination for compressor**

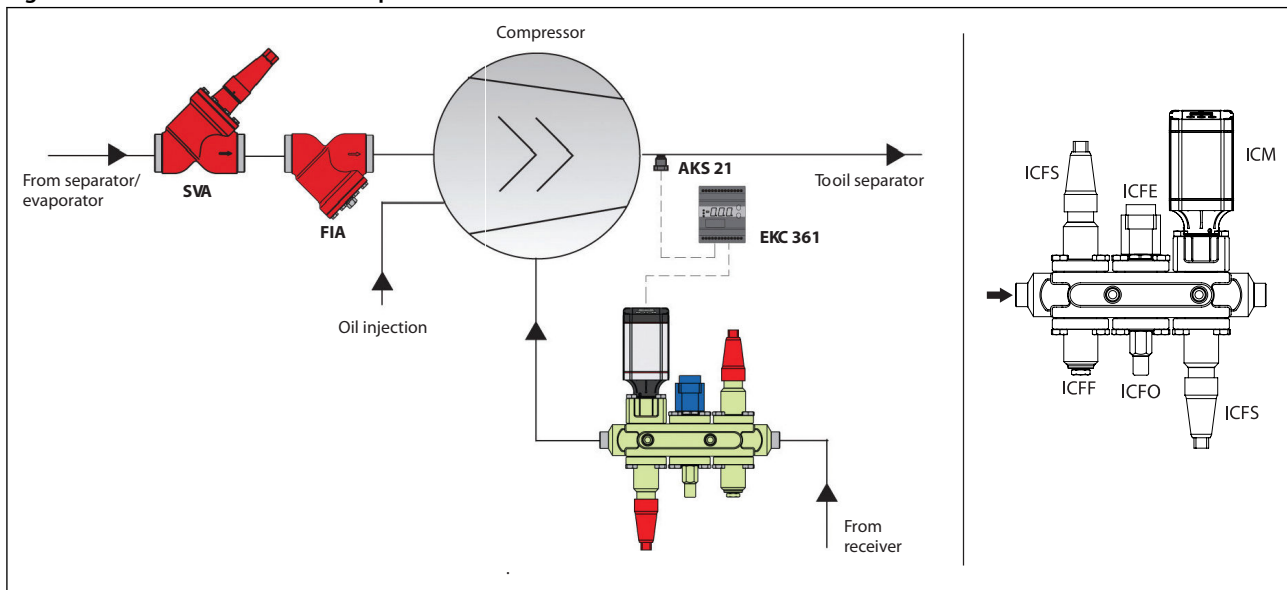

**NOTE:**

Not all valves are shown. Not to be used for construction purposes.

### Liquid feed line / Hot gas defrost line Return line / Defrost drain line

Evaporator with 2 stage gas powered ICLX module in suction line ICF and ICF liquid feed valve station. Hot gas defrost featuring: ICF hot gas valve station with side port to power ICLX module and ICF drain station with float activated liquid drainage to suction line ICF side port.

Figure 5: Liquid feed line / Hot gas defrost line Return line / Defrost drain line

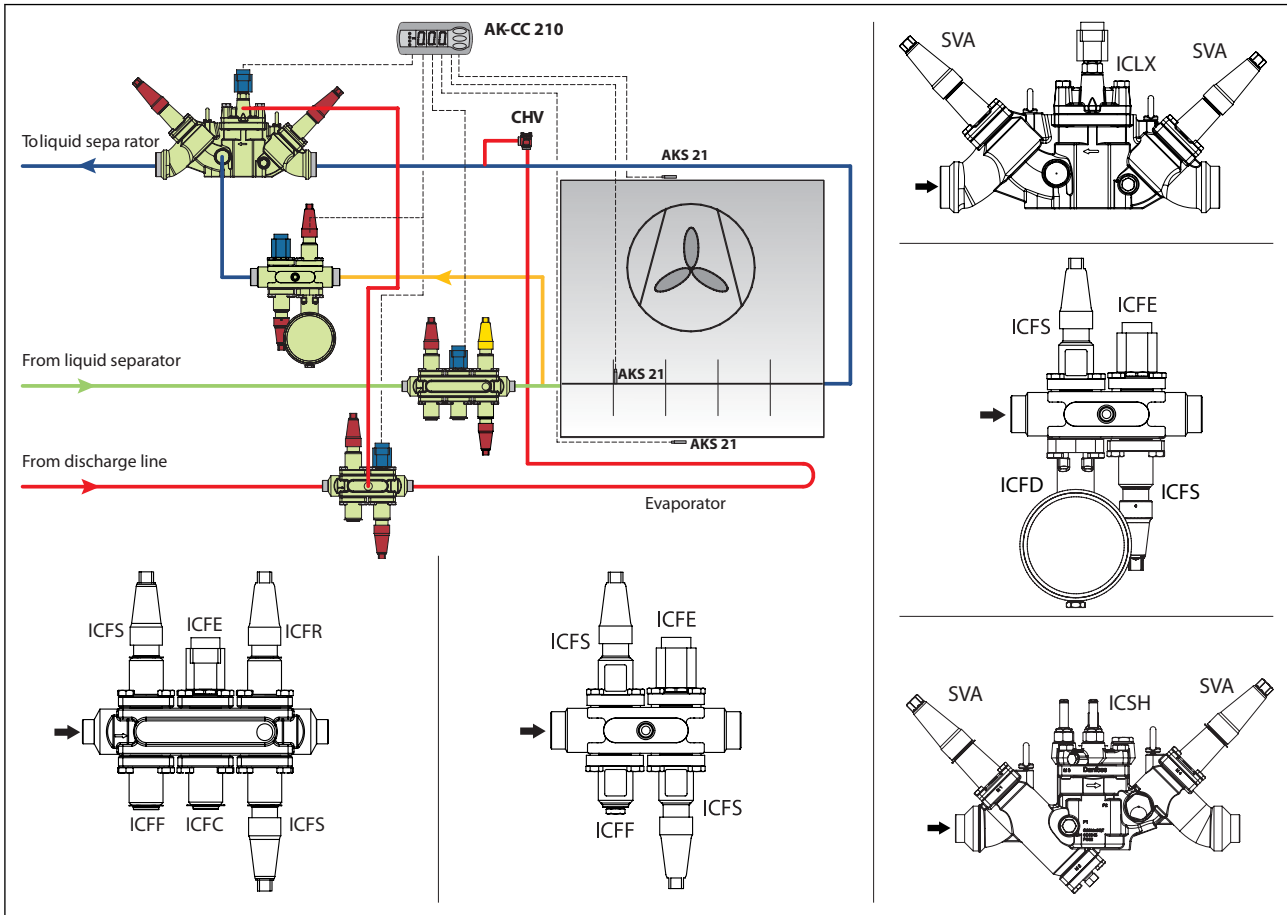

**NOTE:**

Not all valves are shown. Not to be used for construction purposes.

Restrictions to ICF drain station piping - please see [Application guide AB236886443340](#)

## Media

### **Refrigerants**

Applicable to HFC, R717 (Ammonia) and R744 (CO<sub>2</sub>)

The use of ICF valve stations with flammable hydrocarbons is not recommended.

Exception: ICFD is released for ammonia and CO<sub>2</sub> refrigerants.

ICFD 20 - ammonia version.

ICFD 20C - CO<sub>2</sub> version.

Only approved for land-based applications only.

### **New refrigerants**

Danfoss products are continually evaluated for use with new refrigerants depending on market requirements.

When a refrigerant is approved for use by Danfoss, it is added to the relevant portfolio, and the R number of the refrigerant (e.g. R513A) will be added to the technical data of the code number. Therefore, products for specific refrigerants are best checked at [store.danfoss.com/en/](https://store.danfoss.com/en/), or by contacting your local Danfoss representative.



## Functions

**Each housing accommodates a maximum of two, four or six function modules (ICF 65 max. 3), of the following types:**

- Shut-off valve module
- Manual regulating valve module
- Strainer module
- Solenoid valve module
- Electronic expansion valve module
- Manual opening module
- Check valve module
- Stop & check valve module
- Pilot operated servo valve module
- Defrost drain module
- Motor operated valve module
- External welding connection module
- Blind top cover

**Optional:**

**All housings except ICF 20-2 are supplied with a predefined number of side ports for the following options:**

- Sight glass
- Temperature or pressure sensor
- Pressure gauge
- Side exit for drain or bypass.

### Module and side port arrangement

Table 11: Module and side port arrangement

<p style="text-align: center;"><b>ICF 15-4</b></p>	<p style="text-align: center;"><b>Flow in an ICF 15-4</b></p>
<p style="text-align: center;"><b>ICF 20-2</b></p>	<p style="text-align: center;"><b>Flow in an ICF 20-2</b></p>
<p style="text-align: center;"><b>ICF 20-4, 25-4</b></p>	<p style="text-align: center;"><b>Flow in an ICF 20-4, 25-4</b></p>
<p style="text-align: center;"><b>ICF 20-6, 25-6</b></p>	<p style="text-align: center;"><b>Flow in an ICF 20-6, 25-6</b></p>
<p style="text-align: center;"><b>ICF 50-4</b></p>	<p style="text-align: center;"><b>Flow in an ICF 50-4</b></p>
<p style="text-align: center;"><b>ICF 65-3</b></p>	<p style="text-align: center;"><b>Flow in an ICF 65-3</b></p>

## Valve station, type ICF 15, ICF 20, ICF 25, ICF 50 and ICF 65

**NOTE:**

ICF 20-2 has no side ports.

**Table 12: Module and side port arrangement**

<p>All ICF 15-4 DIN, ANSI and Socket connections. 2 side ports - right hand side in flow direction</p> <p>Example: ICF 15-4-8 DIN</p>	<p>All ICF 20/25-4 DIN, ANSI and Socket connections. 4 side ports - 2 opposite on each side</p> <p>Example: ICF 25-4-9 SOC</p>
<p>3/8 in. G for DIN and ANSI connections 3/8 in. NPT for SOC connections</p> <p>Drain Plug Thread: Please refer to Material specification section page 19 - 35</p>	<p>3/8 in. G for DIN and ANSI connections 3/8 in. NPT for SOC connections</p> <p>Drain Plug Thread: Please refer to Material specification section page 19 - 35</p>

**Table 13: Module and side port arrangement**

<p>All ICF 20/25-6 DIN, ANSI and Socket connections. 6 side ports - 3 opposite on each side</p> <p>Example: ICF 20-6-5MB DIN</p>	<p>All ICF 20/25-6 DIN, ANSI and Socket connections. 6 side ports - 3 opposite on each side</p> <p>Example: ICF 20-6-2HRB SOC</p>
<p>3/8 in. G for DIN and ANSI connections 3/8 in. NPT for SOC connections</p> <p>Drain Plug Thread: Please refer to Material specification section page 19 - 35</p>	<p>3/8 in. G for DIN and ANSI connections 3/8 in. NPT for SOC connections</p> <p>Drain Plug Thread: Please refer to Material specification section page 19 - 35</p>

## Valve station, type ICF 15, ICF 20, ICF 25, ICF 50 and ICF 65

**Table 14: Module and side port arrangement**

<p>All ICF 50-4 DIN, ANSI and Socket connections. 4 side ports - 2 opposite on each side</p> <p>Example: ICF 50-4-42S50 SOC</p>	<p>All ICF 65-3 DIN and ANSI connections. 4 side ports - 2 opposite on each side</p> <p>Example: ICF 65-3-43MA DIN</p>

### Description of the function modules for ICF 15 and 20

ICF 15 and ICF 20 have the same function modules except for the two fixed modules M1 (stop valve ICFS 15) and M2 (filter ICFF 15) in ICF 15.

ICF 20-2 is only available with modules ICFE 20, ICFE 20H, ICFB 20 and ICFO 20.

**Table 15: ICFS 15 / ICFS 20 / ICFR 20A / ICFC 20 / ICFC 20P1**

<p>ICFS 15 / ICFS 20 Shut-off valve module This module has the function of a stop valve, and has a red cap</p>	<p>ICFR 20A Manual regulating valve module This module has the function of a hand regulating valve, and has a yellow cap</p>	<p>ICFC 20 / ICFC 20P1 ICFC Standard check valve module  ICFC 20P1 Loaded check valve module Opening pressure of approx. 0.5 bar, and is fully open at 0.7 bar</p>

Valve station, type ICF 15, ICF 20, ICF 25, ICF 50 and ICF 65

**Table 16: ICFF 15/20 / ICFF 20E / ICFN 20 / ICFE 20 / ICFA 20**

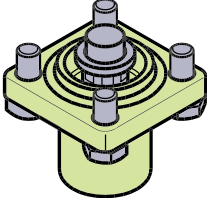
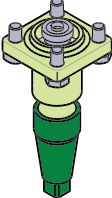
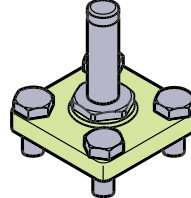
<p>ICFF 15/20 / ICFF 20E Strainer module This module functions as a strainer</p> <p>ICF 15, all connections: Strainer element 150µ (100 mesh) 60 cm<sup>2</sup> (9.3 in<sup>2</sup>)</p> <p>ICF 20, with DIN/ANSI connections: Pleated 150µ (100 mesh) 45 cm<sup>2</sup> (7.0 in<sup>2</sup>)</p> <p>ICF 20 with SOC connections (ICFF 20E): Pleated 150µ (100 mesh) / 160 cm<sup>2</sup> (24.8 in<sup>2</sup>)</p>	<p>ICFN 20 Stop &amp; check valve module This module has the function of a combined stop and check valve, and has a green cap</p>	<p>ICFE 20 Solenoid valve module This module has the function of a normally closed solenoid valve for controlling the refrigerant flow</p> <p>ICFA 20 Electronic expansion valve module This module has the function of an electronic pulse width modulating (PWM) expansion valve</p>
		

**Table 17: ICM 20-A, B or C / ICFO 20 / ICFB 20**

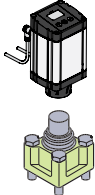
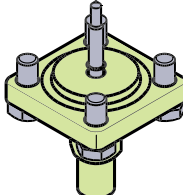
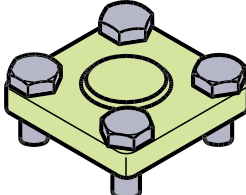
<p>ICM 20-A, B or C Motor operated valve module This module is a stepper motor actuator valve for on/off and modulating control of the refrigerant flow</p>	<p>ICFO 20 Manual opening module This module facilitates the manual opening of the solenoid valve (type ICFE)</p>	<p>ICFB 20 Blind top cover This provides a blanking cover for unused module ports</p>
		

**Table 18: ICFE 20H / ICFW 20 / ICFD 20 / ICFD 20C**

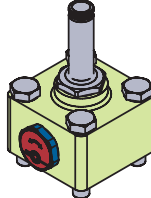
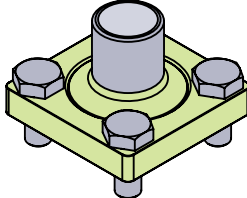
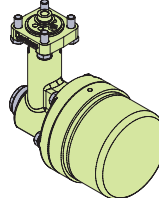
<p>ICFE 20H Solenoid valve module with integrated manual opener This module has the function of a normally closed solenoid valve for controlling the refrigerant flow. A filter before the ICFE 20H is recommended</p>	<p>ICFW 20 Welding module 20 DIN or ¾" SOC This module is used for drain connection during hot-gas defrosting - in case of high capacity</p>	<p>ICFD 20 / ICFD 20C Float operated valve module This module opens for liquid flow when the float is lifted by the internal liquid level</p> <p>ICFD 20 - ammonia version ICFD 20C - CO<sub>2</sub> version</p>
		

**NOTE:**

At about 10% of maximum mass flow of ICFE 20H, the pressure differential correspond to about 0.07 bar/1 psi. ICFE 20H will start to open at these conditions.

At a pressure differential of minimum 0.2 bar/2.9 psi ICFE 20H will be 100% open.

## Description of the function modules for ICF 25

Table 19: ICFS 25 / ICFR 25, A or B / ICFC 25



<p><b>ICFS 25</b> Shut-off valve module This module has the function of a stop valve, and has a red cap</p>	<p><b>ICFR 25, A or B</b> Manual regulating valve module This module has the function of a hand regulating valve, and has a yellow cap</p>	<p><b>ICFC 25</b> Check valve module This module has the function of a check valve</p>
		

Table 20: ICFF 25 / ICFF 25E / ICFN 25 / ICFE 25

<p><b>ICFF 25 / ICFF 25E</b> Strainer module This module functions as a strainer</p> <p>Strainer size: ICF with DIN and ANSI (ICFF 25) connections: Pleated 150<math>\mu</math> (100 mesh) / 160 cm<sup>2</sup> (24.8 in<sup>2</sup>)</p> <p>ICF with SOC connections (ICF 25E): Pleated 150<math>\mu</math> (100 mesh) / 330 cm<sup>2</sup> (51.2 in<sup>2</sup>)</p>	<p><b>ICFN 25</b> Stop &amp; check valve module This module has the function of a combined stop and check valve, and has a green cap</p>	<p><b>ICFE 25</b> Solenoid valve module This module has the function of a normally closed solenoid valve for controlling the refrigerant flow.  It has a built-in manual opening function</p>
		

Table 21: ICM 25-A or B / ICFW 25 / ICFB 25

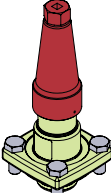
<p><b>ICM 25-A or B</b> Motor operated valve module This module is a stepper motor actuator valve for on/off and modulating control of the refrigerant flow</p>	<p><b>ICFW 25</b> Welding module, 25 DIN or 25 (1") SOC This module is used for drain connection during hot-gas defrosting - in case of high capacity</p>	<p><b>ICFB 25</b> Blind top cover This provides a blanking cover for unused module ports</p>
		

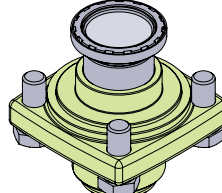
**NOTE:**

At about 10% of maximum mass flow of ICFE 25, the pressure differential correspond to about 0.07 bar/1 psi. ICFE 25 will start to open at these conditions.

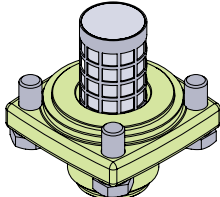
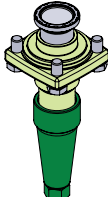
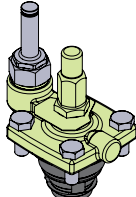
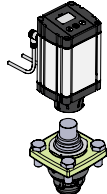
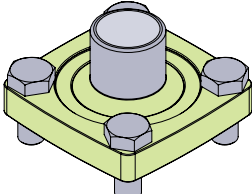
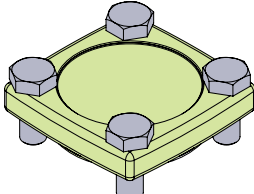
At a pressure differential of minimum 0.2 bar/2.9 psi ICFE 25 will be 100% open.

## Description of the function modules for ICF 50 and ICF 65

Table 22: SVA-S 50 / SVA 65 / REG-SB 50 / REG-SB 65 / ICFB 50



<p>SVA-S 50 / SVA 65 Shut-off valve module This module has the function of a stop valve, and has a red cap</p>	<p>REG-SB 50 / REG-SB 65 Manual regulating valve module This module has the function of a hand regulating valve, and has a yellow cap</p>	<p>ICFB 50 Blind cover Prepared for insert of strainer (see below)</p>
		

Table 23: ICM 50 / ICM 65 - A or B / ICLX 50 / ICLX 65 / ICSH 50 / ICSH 65

<p>ICM 50 / ICM 65 - A or B Motor operated valve module This module is a stepper motor actuator valve for on/off and modulating control of the refrigerant flow</p>	<p>ICLX 50 / ICLX 65 2-step solenoid valve module This module has the function of a normally closed gas powered solenoid valve for controlling the refrigerant flow It has a built-in manual opening function ICLX is used in suction lines for opening in 2 steps after hot gas defrost</p>	<p>ICSH 50/ICSH 65 2-step solenoid valve module This module has the function of a normally closed solenoid valve for controlling the refrigerant flow It has a built-in manual opening function ICSH is used in hot gas lines for the opening of hot gas defrost flow to the evaporator in 2 steps</p>
		

Table 24: ICS 50 / ICS 65 / FIA 50

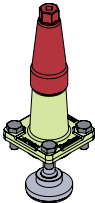
<p>ICS 50 / ICS 65 Pilot-operated valve module This module has the function of a pilot-operated valve for on/off and modulating control of the refrigerant flow</p> <p>All ICS modules are 3-pilot versions. They are supplied with two blanking plugs (A) and one sealing plug (B)</p> <p>ICS 50 and 65 inserts are available in different capacities: ICS 50: ICS 50 ICS 50-32 ICS 50-40</p> <p>ICS 65: ICS 65 ICS 65-40 ICS 80</p>	
---	---

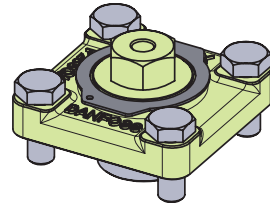
Valve station, type ICF 15, ICF 20, ICF 25, ICF 50 and ICF 65

**Table 25: ICS 50 / ICS 65 / FIA 50**

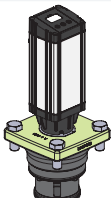
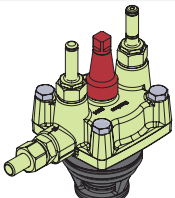
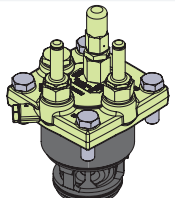
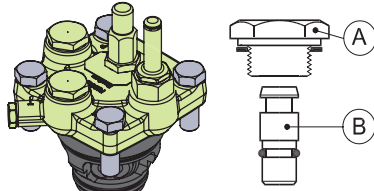
FIA 50 (option)  
 Strainer insert  
 Please order FIA 50 strainer insert and element from the FIA part programme. For further information please consult the data sheet for FIA strainers  
 Available elements:  
 See below



**Table 26: Strainer insert**

Strainer insert	Strainer insert	Strainer insert	Strainer insert	Pleated Strainer insert	Pleated Strainer insert	Pleated Strainer insert
100µ 150 mesh	150µ 100 mesh	250µ 72 mesh	500µ 38 mesh	150µ 100 mesh	250µ 72 mesh	500µ 38 mesh
<b>148H3157</b>	<b>148H3130</b>	<b>148H3138</b>	<b>148H3144</b>	<b>148H3179</b>	<b>148H3184</b>	<b>148H3189</b>



## Product specification

### Pressure and temperature

#### Temperature range

ICF complete platform  
-60/+120 °C (-76/+ 248 °F)

#### Exceptions

ICM: If the ICM module is going to be used in liquid refrigerant with a temperature above 75 °C (167 °F) please contact Danfoss.

**ICFD 20:** -50/+50 °C (-58/+122 °F) at  
28 bar (406 psig)

**ICFD 20C:** -50/+50 °C (-58/+122 °F) at  
52 bar (754 psig)

#### Ambient temperature for ICF with ICAD

-30/+50 °C (-22/+122 °F)

#### Surface protection

The external surface is zinc-TLP treated to provide corrosion protection according to EN ISO 2081:2009. Additional on-site corrosion protection is recommended.

#### Pressure

The general ICF is designed for max. working pressure: 52 bar (754 psig).

#### ICF 20-2:

Max. working pressure: 65 bar (943 psig).

#### ICFD 20 (Ammonia):

For ICF with ICFD module the max. working pressure is 28 bar/406 psig. If the refrigeration system include ICFD 20 module, a test pressure of the system must not exceed 28 bar/406 psig, unless the ICFD float is temporarily taken out before test.

#### ICFD 20C (CO<sub>2</sub>)

For ICF with ICFD 20C module the max. working pressure is 52 bar/754 psig. If the refrigeration system include ICFD 20 module, a test pressure of the system must not exceed 52 bar/754 psig, unless the ICFD 20C float is temporarily taken out before test.

Max. working pressure for ICFD without float: 52 bar (754 psig).

#### Maximum differential pressure

**ICFD 20:** 15 bar/218 psig. For higher differential pressure, please contact Danfoss.

**ICFD 20C:** 36 bar/522 psig.

### Design

#### The main components of the ICF valve station are:

- A housing
- A maximum of two, four or six function modules (ICF 65 - max. 3)
  - In all ICF 15 the modules M1 and M2 are predefined as shut-off valve and strainer module
  - In all ICF 50 the modules M1 and M2 are predefined as shut-off valve and blind cover (prepared for strainer)
  - In all ICF 65 the module M1 is predefined as shut-off valve

### Housing

The design allows maximum capacity and minimum pressure drop, using advanced technology and double seats – offering higher capacity than conventional systems using individual valves and components.

The ICF valve station is multifunctional.

## Valve station, type ICF 15, ICF 20, ICF 25, ICF 50 and ICF 65

ICF valve station offers compact dimensions and shortened installation time due to the reduced number of direct welded connections.

Supplied as a complete assembly, it is leak tested at high pressure and its functions are tested under factory controlled conditions.

Table 27: Housing

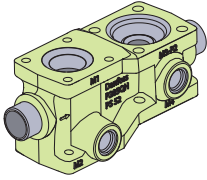
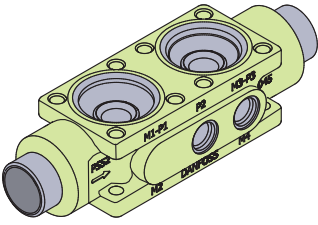
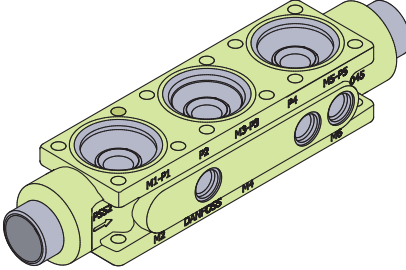
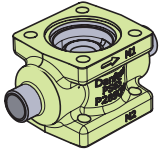
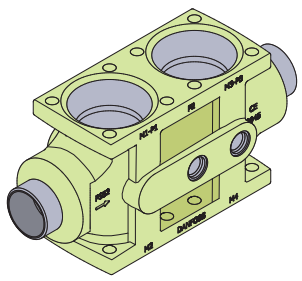
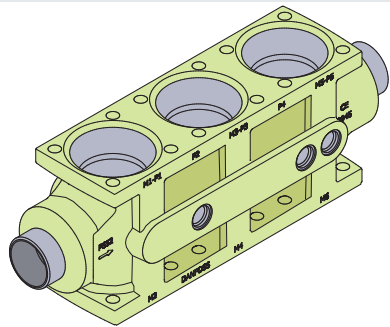
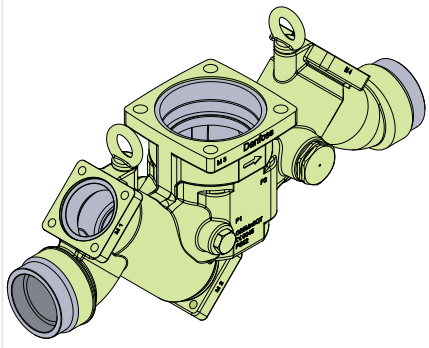
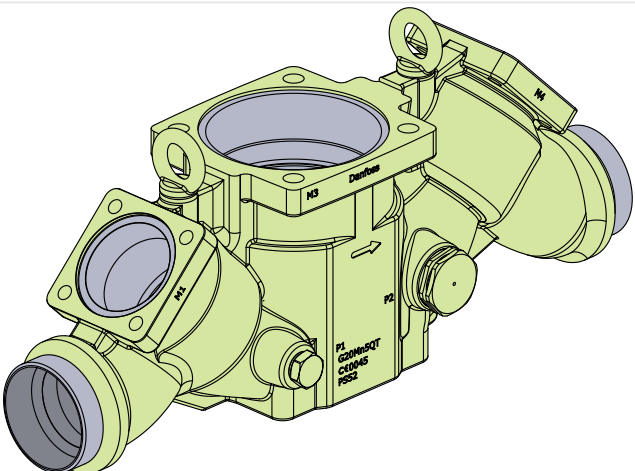
<p style="text-align: center;">ICF 15-4</p> 	<p style="text-align: center;">ICF 20-4</p> 	<p style="text-align: center;">ICF 20-6</p> 
<p style="text-align: center;">ICF 20-2</p> 	<p style="text-align: center;">ICF 25-4</p> 	<p style="text-align: center;">ICF 25-6</p> 
<p style="text-align: center;">ICF 50-4</p> 	<p style="text-align: center;">ICF 65-3</p> 	

### Housing and function module material

Low temperature steel

**NOTE:**

When using TIG/MIG/SMAW welding technology, it is possible to install the ICF valve station without prior removal of the function modules from the housing. If using other welding methods or brazing the modules must be removed during the process.

Please consult the product instruction for more details and exceptions.

## Material specification

### ICF housing

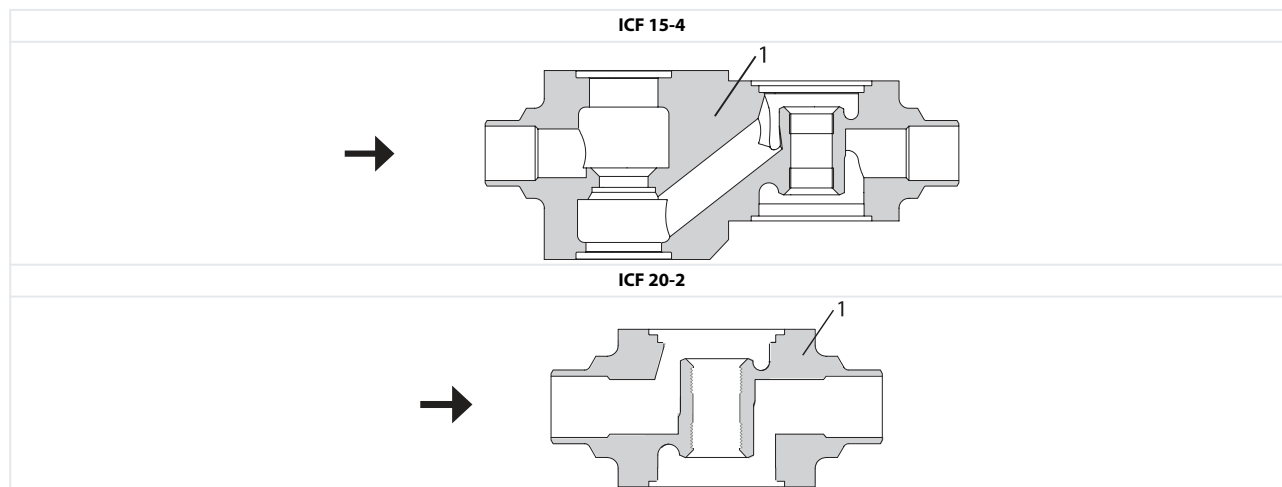

Table 28: ICF 15-4 & ICF 20-2

Pos.	Part	Material	EN <sup>(1)</sup>	ASTM <sup>(2)</sup>	JIS <sup>(2)</sup>
1	Housing	Steel	P285QH, 10222-4	LF2, A350	

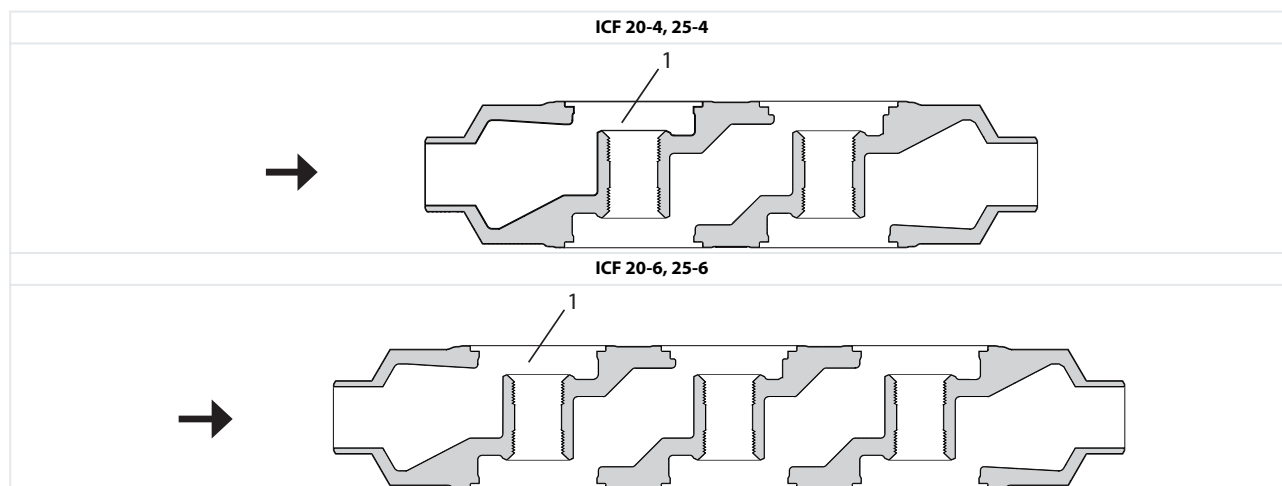

Table 29: ICF 20-4, 25-4 & ICF 20-6, 25-6

Pos.	Part	Material	EN <sup>(1)</sup>	ASTM <sup>(2)</sup>	JIS <sup>(2)</sup>
1	Housing	Cast steel low temperature	G20MNSQT EN 10213-3	LCC, A352	SCPL1, G5151

<sup>(1)</sup> Primary Design Standard

<sup>(2)</sup> Equivalent Material Standard

Valve station, type ICF 15, ICF 20, ICF 25, ICF 50 and ICF 65

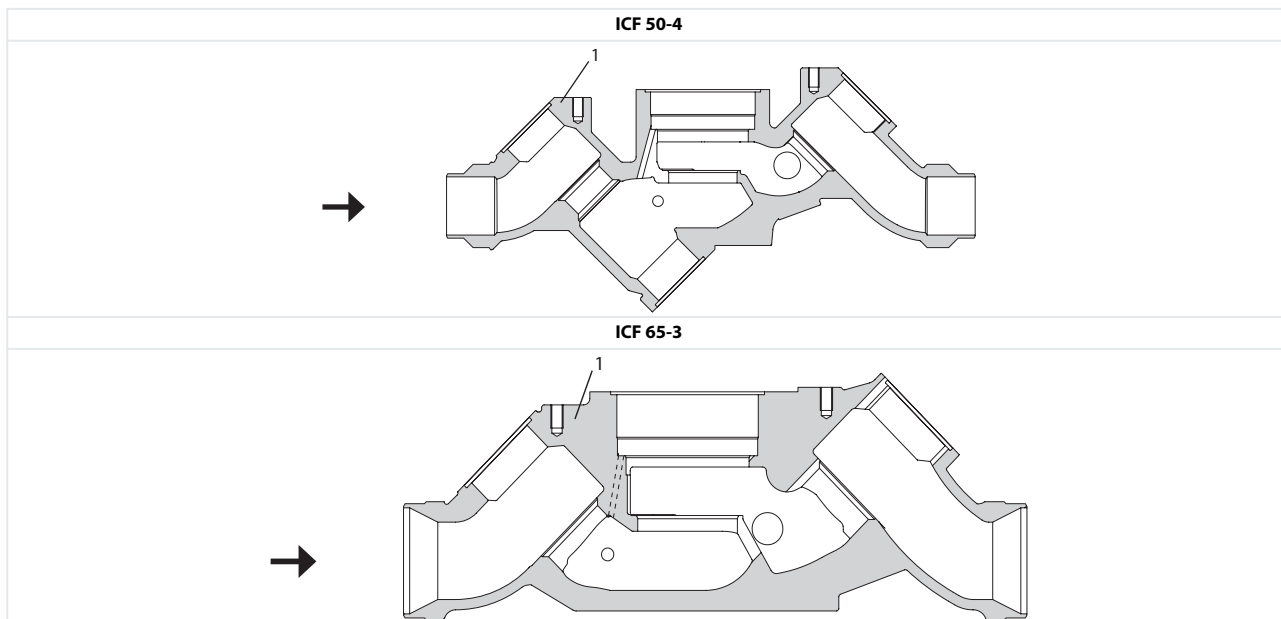

Table 30: ICF 50-4 & ICF 65-3

Pos.	Part	Material	EN <sup>(1)</sup>	ASTM <sup>(2)</sup>	JIS <sup>(2)</sup>
1	Housing	Cast steel low temperature	G20Mn5QT EN 10213-3	LCC, A352	SCPL1, G5151

<sup>(1)</sup> Primary Design Standard

<sup>(2)</sup> Equivalent Material Standard

ICFS 15 shut-off valve module

Figure 6: ICFS 15 shut-off valve module

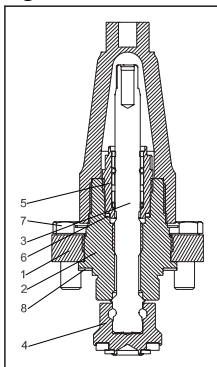

Table 31: ICFS 15 shut-off valve module

Pos.	Part	Material	EN <sup>(1)</sup>	ASTM <sup>(2)</sup>	JIS <sup>(2)</sup>
1	Bonnet, Flange Steel	Steel	G20Mn5QT 10213-3 P285QH+QT 10222-4 P275NL 10028-3	LCC, A352 LF2, A350	
2	Bonnet, Insert	Steel	11SMn30 10087	AISI 1213	Type 2 R 683/9
3	Spindle	Stainless steel	X8CrNiS18-9 10088	AISI 303	Type 17 683/13
4	Cone	Steel	11SMn30 10087	AISI 1213	Type 2 R 683/9
5	Packing gland	Stainless steel	X8CrNiS18-9 10088	AISI 303	Type 17 683/13

## Valve station, type ICF 15, ICF 20, ICF 25, ICF 50 and ICF 65

Pos.	Part	Material	EN <sup>(1)</sup>	ASTM <sup>(2)</sup>	JIS <sup>(2)</sup>
6	Packing washer	Aluminium			
7	Bolts	Stainless steel	A2-70	Type 308	A2-70
8	Gasket	Fiber, Non-asbestos			

### ICFS 20 shut-off valve module

Figure 7: ICFS 20 shut-off valve module

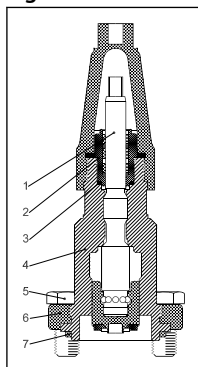

Table 32: ICFS 20 shut-off valve module

Pos.	Part	Material	EN <sup>(1)</sup>	ASTM <sup>(2)</sup>	JIS <sup>(2)</sup>
1	Spindle	Stainless steel	X8CrNiS 18-9 EN 10088		G4303 G4304
2	Thread part	Stainless steel	X8CrNiS 18-9 EN 10088		G4303 G4304
3	AL-gasket/Refrig. Gasket		AL99 alloy no. 1200 DIN 1712 BL.3	AL1200	
4	Bonnet	Steel	S235JRG2 EN 10025	A283	G3101
5	Hex-head bolt M10 × 25	Stainless steel	A2-70 EN 24017	A320	A2-70
6	Flange	Cast steel low temperature	G20Mn5QT, 10213-3 P285QH+QT, 10222-4 P275NL, 10028-3	A352	G5152
7	Gasket	Chloroprene (Neoprene)			

### ICFF 15 strainer module (strainer element 150 $\mu$ (100 mesh) 60 cm<sup>2</sup> (9.3 in<sup>2</sup>))

Figure 8:

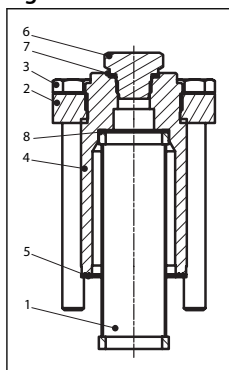

Table 33: ICFF 15 strainer module (strainer element 150 $\mu$  (100 mesh) 60 cm<sup>2</sup> (9.3 in<sup>2</sup>))

Pos.	Part	Material	EN <sup>(1)</sup>	ASTM <sup>(2)</sup>	JIS <sup>(2)</sup>
1	Strainer	Stainless steel			
2	Flange bonnet	Steel	G20Mn5QT, 10213-3 P285QH+QT, 10222-4 P275NL, 10028-3	LCC, A352 LF2, A350	
3	Bolt	Stainless steel	A2-70	Type 308	A2-70
4	ICFF 15 bonnet	Steel	S355J2+N 1.0570 / 1.0577 EN 10025-2	ASTM A572-50	

## Valve station, type ICF 15, ICF 20, ICF 25, ICF 50 and ICF 65

Pos.	Part	Material	EN <sup>(1)</sup>	ASTM <sup>(2)</sup>	JIS <sup>(2)</sup>
5	Flat gasket	Fiber, Non-asbestos			
6	Plug 1/4" RG for butt-weld 3/8" NPT for socket weld	Steel	11SMnPb30		
7	Gasket - metal joint	Aluminium			
8	Wave spring	Steel			

### ICFF 20 strainer module

Figure 9: ICFF 20 strainer module

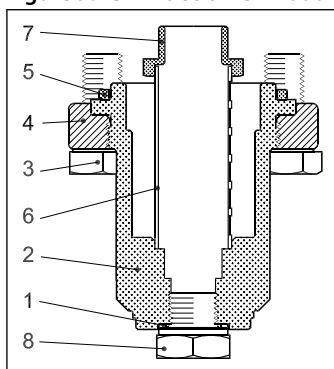

Table 34: ICFF 20 strainer module

Pos.	Part	Material	EN <sup>(1)</sup>	ASTM <sup>(2)</sup>	JIS <sup>(2)</sup>
1	Gasket	AL 99 F11			
2	Bonnet	Steel	S235JRG2 EN 10025	A283	G3101
3	Hex-head bolt M10 x 25	Stainless steel	A2-70 EN 24017	A320	A2-70
4	Flange	Cast steel low temperature	G20Mn5QT, 10213-3 P285QH+QT, 10222-4 P275NL, 10028-3	A352	G5152
5	Gasket	Chloroprene (Neoprene)			
6	Strainer element	Stainless steel 150μ	1.4301	A304	SUS304
7	Plug	Steel			
8	Plug 1/4" RG for butt-weld 3/8" NPT for socket weld	Stainless steel	A2-70 EN 24017	A320	A2-70

### ICFF 20E extended strainer module

Figure 10: ICFF 20E extended strainer module

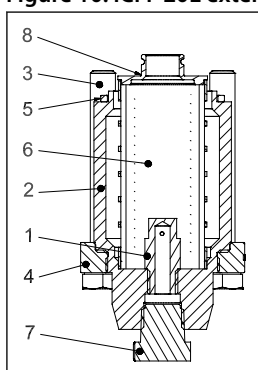

Table 35: ICFF 20E extended strainer module

Pos.	Part	Material	EN <sup>(1)</sup>	ASTM <sup>(2)</sup>	JIS <sup>(2)</sup>
1	Dirt protection plug	Steel	11SMn30 EN 10087	Grade 1213 A29	G4804
2	Bonnet	Steel	11SMn30 EN 10087	Grade 1213 A29	G4804
3	Hex-head bolt M12x80	Stainless steel	A2-70 EN 1515-1	Grade B8 A320	A2-70 B1054

## Valve station, type ICF 15, ICF 20, ICF 25, ICF 50 and ICF 65

Pos.	Part	Material	EN <sup>(1)</sup>	ASTM <sup>(2)</sup>	JIS <sup>(2)</sup>
4	Flange	Steel	G20Mn5QT, 10213-3 P285QH+QT, 10222-4 P275NL, 10028-3	LF2 - A350 LCC - A352	SFL2 - G3205 SCPL1 - G5152
5	Gasket	Chloroprene (Neoprene)			
6	Strainer element	Stainless steel 250m	1.4301	A304	SUS304
7	Plug 3/8" NPT	Steel	11SMn30 EN 10087	Grade 1213 A29	G4804
8	Strainer adaptor	Steel	11SMn30 EN 10087	Grade 1213 A29	G4804

### ICFE 20 solenoid valve module

Figure 11: ICFE 20 solenoid valve module

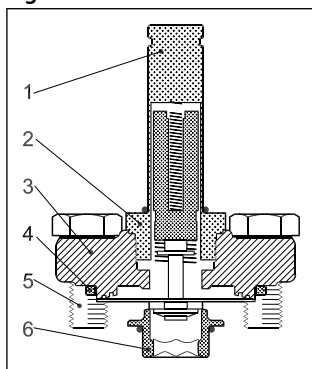
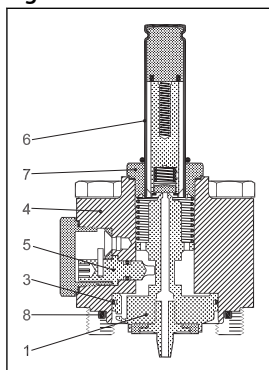

Table 36: ICFE 20 solenoid valve module

Pos.	Part	Material	EN <sup>(1)</sup>	ASTM <sup>(2)</sup>	JIS <sup>(2)</sup>
1	Armature tube	Stainless steel	X2CrNi19-11 EN 10088		
2	Armature tube nut	Stainless steel	X8CrNiS18-9 EN 10088		
3	Flange	Cast Steel low temperature	G20Mn5QT, 10213-3 P285QH+QT, 10222-4 P275NL, 10028-3	A352	G5152
4	Gasket	ICF 15-4, ICF 20-4/6 Chloroprene (Neoprene) ICF 20-2: Fiber (Non-asbestos)			
5	Hex-Head bolt M10 x 25	Stainless steel	A2-70 EN 24017	A320	A2-70
6	Seat	High density polymer			

### ICFE 20H solenoid valve module

Figure 12: ICFE 20H solenoid valve module



## Valve station, type ICF 15, ICF 20, ICF 25, ICF 50 and ICF 65

**Table 37: ICFE 20H solenoid valve module**

Pos.	Part	Material	EN <sup>(1)</sup>	ASTM <sup>(2)</sup>	JIS <sup>(2)</sup>
1	Piston	Steel	115Mn30 EN 10025		
2	Seat	Teflon			
3	Piston ring				
4	Bonnet cylinder	Steel	P285QH EN 10222	A350	G3205
5	Manual opener	Steel			
6	Armature tube	Stainless steel	X2CrNi19-11 EN10028		
7	Armature tube nut	Stainless steel	X2CrNi19-11 EN10216	A320	A2-70
8	Gasket	ICF 15-4, ICF 20-4/6 Chloroprene (Neoprene) ICF 20-2: Fiber (Non-asbestos)			

## ICFO 20 manual opening module

**Figure 13:**

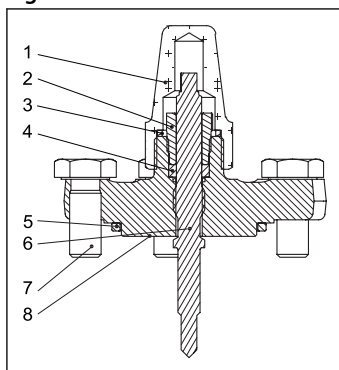

**Table 38: ICFO 20 manual opening module**

Pos.	Part	Material	EN <sup>(1)</sup>	ASTM <sup>(2)</sup>	JIS <sup>(2)</sup>
1	Seal cap	Steel	DIN 1651-95Mn28 TLP surface treatment	1213 (SAE)	SUM 22
2	Gland nut	Steel	DIN 1651 95Mn28 Zinc Chromate Surface treatment	1213 (SAE)	SUM 22
3	Seal cap gasket	Nylon	Polyamid A6	Polyamid PA6	Polyamid PA6
4	Sealing ring	Teflon	PTFE	PTFE	PTFE
5	Gasket	ICF 15-4, ICF 20-4/6 Chloroprene (Neoprene) ICF 20-2: Fiber (Non-asbestos)	CR	CR	CR
6	Spindle	Stainless steel	X8CrNiS 18-9 EN 10088	G4303 G4304	SUS 303
7	Hex-head bolt M10 × 25	Stainless steel	A2-70 EN 24017	A320	A2-70
8	Flange	Cast steel low temperature	EN10222-4 P285QH		



## ICFR 20 manual regulating valve module

Figure 14: ICFR 20 manual regulating valve module

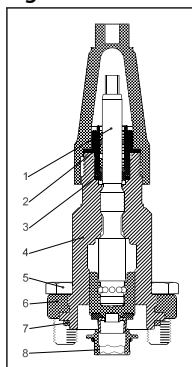

Table 39: ICFR 20 manual regulating valve module

Pos.	Part	Material	EN <sup>(1)</sup>	ASTM <sup>(2)</sup>	JIS <sup>(2)</sup>
1	Spindle	Stainless steel	X8CrNiS 18-9 EN 10088		G4303 G4304
2	Thread part	Stainless steel	X8CrNiS 18-9 EN 10088		G4303 G4304
3	AL-gasket		AL99 alloy no. 1200 DIN 1712 BL.3		
4	Bonnet	Steel	S235JRG2 EN 10025	A283	G3101
5	Hex-head bolt M10 × 25	Stainless steel	A2-70 EN 24017	A320	A2-70
6	Flange	Cast steel low temperature	G20Mn5QT, 10213-3 P285QH+QT, 10222-4 P275NL, 10028-3	A352	G5152
7	Gasket	Chloroprene (Neoprene)			
8	Seat	High density polymer			

## ICFA 20 electronic expansion valve module

Figure 15: ICFA 20 electronic expansion valve module

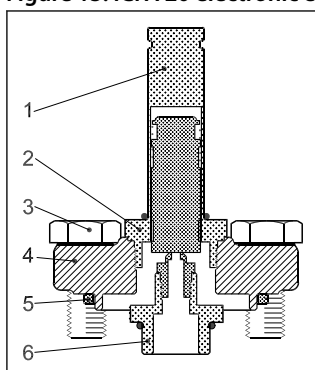

Table 40: ICFA 20 electronic expansion valve module

Pos.	Part	Material	EN <sup>(1)</sup>	ASTM <sup>(2)</sup>	JIS <sup>(2)</sup>
1	Armature tube	Stainless steel	X2CrNi19-11 EN 10088		
2	Armature tube nut	Stainless steel	X8CrNiS18-9 EN 10088		
3	Hex-head bolt M10 × 25	Stainless steel	A2-70 EN 24017	A320	A2-70
4	Flange	Cast steel low temperature	G20Mn5QT, 10213-3 P285QH+QT, 10222-4 P275NL, 10028-3	A352	G5152
5	Gasket	Chloroprene (Neoprene)			
6	Adaptor	Steel			

### ICFC 20 check valve module

Figure 16: ICFC 20 check valve module

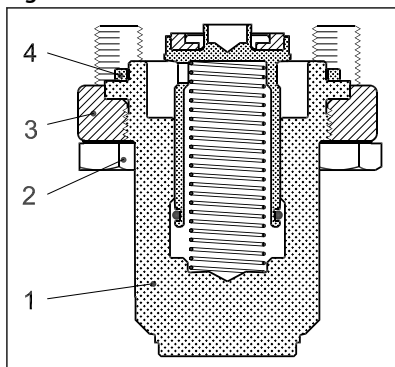

Table 41: ICFC 20 check valve module

Pos.	Part	Material	EN <sup>(1)</sup>	ASTM <sup>(2)</sup>	JIS <sup>(2)</sup>
1	Bonnet	Steel	S235JRG2	A283	G3101
2	Hex-head bolt M10 × 25	Stainless steel	A2-70 EN 24017	A320	A2-70
3	Flange	Cast steel low temperature	G20Mn5QT, 10213-3 P285QH+QT, 10222-4 P275NL, 10028-3	A352	AG5152
4	Gasket	Chloroprene (Neoprene)			

### ICFC 20P1 check valve module

Figure 17: ICFC 20P1 check valve module

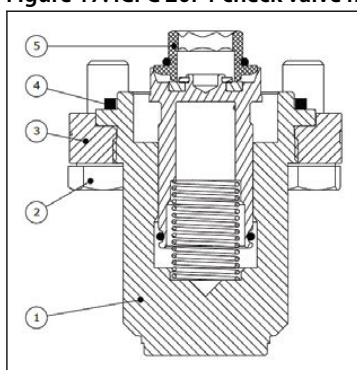

Table 42: ICFC 20P1 check valve module

Pos.	Part	Material	EN <sup>(1)</sup>	ASTM <sup>(2)</sup>	JIS <sup>(2)</sup>
1	Bonnet	Steel	S235JRG2	A283	G3101
2	Hex-head bolt M10 × 25	Stainless steel	A2-70 EN 24017	A320	A2-70
3	Flange	Cast steel low temperature	G20Mn5QT, 10213-3 P285QH+QT, 10222-4 P275NL, 10028-3	A352	AG5152
4	Gasket	Chloroprene (Neoprene)			
5	High density polymer				

## ICFN 20 stop & check valve module

Figure 18: ICFN 20 stop & check valve module

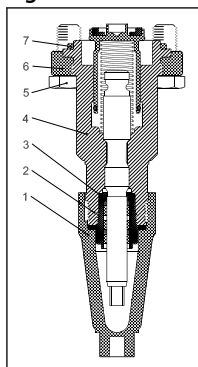

Table 43: ICFN 20 stop & check valve module

Pos.	Part	Material	EN <sup>(1)</sup>	ASTM <sup>(2)</sup>	JIS <sup>(2)</sup>
1	Spindle	Stainless steel	X8CrNiS 18-9 EN 10088		G4303 G4304
2	Thread part	Stainless steel	X8CrNiS 18-9 EN 10088		G4303 G4304
3	AL-gasket		AL99 alloy no. 1200 DIN 1712 BL.3		
4	Bonnet	Steel	S235JRG2 EN 10025	A283	G3101
5	Hex-head bolt M10 × 25	Stainless steel	A2-70 EN 24017	A320	A2-70
6	Flange	Cast steel low temperature	G20Mn5QT, 10213-3 P285QH+QT, 10222-4 P275NL, 10028-3	A352	G5152
7	Gasket	Chloroprene (Neoprene)			

## ICM 20-A, 20-B or 20-C motor operated valve module

Figure 19: ICM 20-A, 20-B or 20-C motor operated valve module

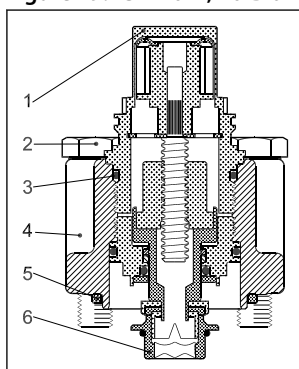

Table 44: ICM 20-A, 20-B or 20-C motor operated valve module

Pos.	Part	Material	EN <sup>(1)</sup>	ASTM <sup>(2)</sup>	JIS <sup>(2)</sup>
1	Spindle	Stainless steel	X8CrNiS 18-9 EN 10088	A240	G4303 G4304
2	Thread part	Stainless steel	A2-70 EN 2401	A320	A2-70
3	AL-gasket	Chloroprene			
4	Bonnet	Cast steel low temperature	G20Mn5QT EN 10213-3	A352	G5152
5	Gasket	Chloroprene (Neoprene)			
6	Seat	High density polymer			

## ICFD 20 / ICFD 20C defrost module

Figure 20: ICFD 20 / ICFD 20C defrost module

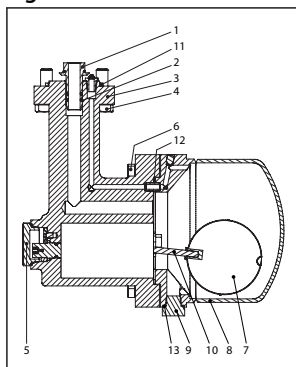

Table 45: ICFD 20 / ICFD 20C defrost module

Pos.	Part	Material	EN <sup>(1)</sup>	ASTM <sup>(2)</sup>	JIS <sup>(2)</sup>
1	Inlet connector	steel	S235JR EN 10025 - 2	A283	G3101
2	O-ring Inlet connector	Chloroprene			
3	Valve Body	Cast Iron	EN -GJS- 400- 18-LT EN 1563		
4	Hex-head bolt M10x30	Stainless Steel	A2-70 EN 24017	A320	A2-70
5	Union nut	Stainless Steel	X8CrNiS18-9 EN 10088-3	AISI303	SUS303
6	Hex-head bolt M10x35	Stainless Steel	A2-70 EN 24017	A320	A2-70
7	Float	Stainless Steel	ICFD 20 : AISI 316 ICFD 20C : AISI 304		
8	Float housing	Stainless Steel	S355J2+N EN 10025-2	A572-50	SM490YB
9	Drain plug 1/4" G	Steel	11SMnPb30 EN 10087		
10	Float lever	Steel	S235JR EN 10025 - 2	A283	G3101
11	Rubber Gasket	Chloroprene (Neoprene)			
12	Gasket	Fibre, Non Asbestos			
13	Gasket - Drain Plug	AL 99F11			

## ICFB 20 blind top cover

Figure 21: ICFB 20 blind top cover

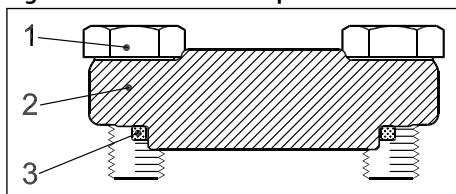

Table 46: ICFB 20 blind top cover

Pos.	Part	Material	EN <sup>(1)</sup>	ASTM <sup>(2)</sup>	JIS <sup>(2)</sup>
1	Hex-head bolt M10 × 25	Stainless Steel	A2-70 EN 24017	A320	A2-70
2	Flange	Cast steel low temperature	G20Mn5QT, 10213-3 P285QH+QT, 10222-4 P275NL, 10028-3	A352	G5152
3	Gasket	ICF 15-4, ICF 20-4/6 Chloro- prene (Neoprene) ICF 20-2: Fiber (Non-asbes- tos)			

## ICFW 20 welding module, 20 DIN or 3/4" SOC

Figure 22: ICFW 20 welding module, 20 DIN or 3/4" SOC

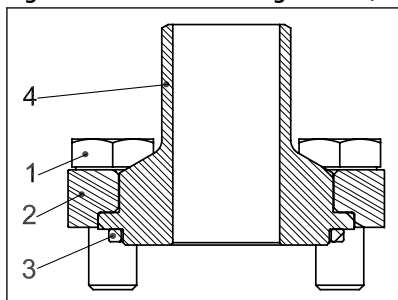

Table 47: ICFW 20 welding module, 20 DIN or 3/4" SOC

Pos.	Part	Material	EN <sup>(1)</sup>	ASTM <sup>(2)</sup>	JIS <sup>(2)</sup>
1	Hex-head bolt M10 × 25	Stainless Steel	A2-70 EN 24017	A320	A2-70
2	Flange	Cast steel low temperature	G20Mn5QT, 10213-3 P285QH+QT, 10222-4 P275NL, 10028-3	A352	G5152
3	Gasket	Chloroprene (Neoprene)			
4	Weld connection				

## ICFS 25 shut-off valve module

Figure 23: ICFS 25 shut-off valve module

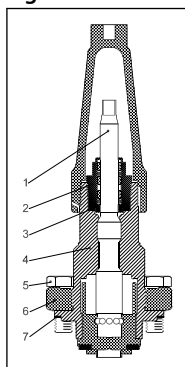

Table 48: ICFS 25 shut-off valve module

Pos.	Part	Material	EN <sup>(1)</sup>	ASTM <sup>(2)</sup>	JIS <sup>(2)</sup>
1	Spindle	Stainless steel	X8CrNiS 18-9 EN 10088		G4303 G4304
2	Thread part	Stainless steel	X8CrNiS18-9 EN 10088		G4303 G4304
3	O-ring	Chloroprene			
4	Bonnet	Steel	S355J2+N 1.0570 / 1.0577 EN 10025-2	ASTM A572-50	
5	Hex-head bolt M12 × 30	Stainless steel	A2-70 EN 24017	A320	A2-70
6	Flange	Cast steel low temperature	G20Mn5QT, 10213-3 P285QH+QT, 10222-4 P275NL, 10028-3	A352	G5152
7	Gasket	Fiber non asbestos			

## ICFF 25 strainer module

Figure 24: ICFF 25 strainer module

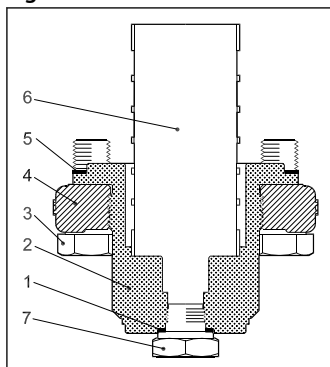

Table 49: ICFS 25 shut-off valve module

Pos.	Part	Material	EN <sup>(1)</sup>	ASTM <sup>(2)</sup>	JIS <sup>(2)</sup>
1	Al. Gasket	AL 99 F11			
2	Bonnet	Steel	S355J2+N 1.0570 / 1.0577 EN 10025-2	ASTM A572-50	
3	Hex-head bolt M12 × 30	Stainless steel	A2-70 EN 24017	A320	A2-70
4	Flange	Cast steel low temperature	G20Mn5QT, 10213-3 P285QH+QT, 10222-4 P275NL, 10028-3	A352	G5152
5	Gasket	Fiber non asbestos			
6	Strainer element	Stainless steel 150μ	1.4301	A304	SUS304
7	Plug 1/4" RG for butt-weld 3/8" NPT for socket weld	Stainless steel	A2-70 EN 24017	A320	A2-70

## ICFF 25E extended strainer module

Figure 25:

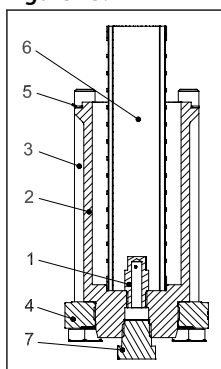

Table 50: ICFF 25E extended strainer module

Pos.	Part	Material	EN <sup>(1)</sup>	ASTM <sup>(2)</sup>	JIS <sup>(2)</sup>
1	Dirt protection plug	Steel		Grade 1213 A29	G4804
2	Bonnet	Steel	S355J2+N 1.0570 / 1.0577 EN 10025-2	ASTM A572-50	
3	Hex-head bolt M12x140	Stainless steel	A2-70 EN 1515-1	Grade B8 A320	A2-70 B1054
4	Flange	Steel	G20Mn5QT, 10213-3 P285QH+QT, 10222-4 P275NL, 10028-3	LF2 - A350 LCC - A352	SFL2 - G3205 SCPL1 - G5152

## Valve station, type ICF 15, ICF 20, ICF 25, ICF 50 and ICF 65

Pos.	Part	Material	EN <sup>(1)</sup>	ASTM <sup>(2)</sup>	JIS <sup>(2)</sup>
5	Gasket	Fiber non asbestos			
6	Strainer element	Stainless steel 250m	1.4301	A304	SUS304
7	Plug 3/8" NPT	Steel	11SMn30 EN 10087	Grade 1213 A29	A29

### ICFE 25 solenoid valve module

Figure 26: ICFE 25 solenoid valve module

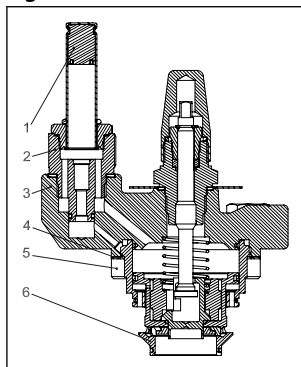

Table 51: ICFE 25 solenoid valve module

Pos.	Part	Material	EN <sup>(1)</sup>	ASTM <sup>(2)</sup>	JIS <sup>(2)</sup>
1	Armature tube	Stainless steel	X2CrNi19-11 EN 10088		
2	Armature tube nut	Stainless steel	X8CrNiS18-9 EN 10088		
3	Bonnet	Cast steel low temperature	G20Mn5QT, 10213-3 P285QH+QT, 10222-4	A352	G5152
4	Gasket	Fiber non asbestos			
5	Hex-Head bolt M10 × 25	Stainless steel	A2-70 EN 24017	A320	A2-70
6	Seat	High density polymer			

### ICFR 25 manual regulating valve module, A or B

Figure 27: ICFR 25 manual regulating valve module, A or B

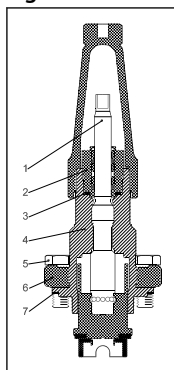

Table 52: ICFR 25 manual regulating valve module, A or B

Pos.	Part	Material	EN <sup>(1)</sup>	ASTM <sup>(2)</sup>	JIS <sup>(2)</sup>
1	Spindle	Stainless steel	X8CrNiS 18-9 EN 10088	G4303 G4304	
2	Thread part	Stainless steel	X8CrNiS 18-9 EN 10088	G4303 G4304	
3	O-ring	Chloroprene			
4	Bonnet	Steel	S355J2+N 1.0570 / 1.0577 EN 10025-2	ASTM A572-50	
5	Hex-head bolt M12 × 30	Stainless steel	A2-70 EN 24017	A320	A2-70

## Valve station, type ICF 15, ICF 20, ICF 25, ICF 50 and ICF 65

Pos.	Part	Material	EN <sup>(1)</sup>	ASTM <sup>(2)</sup>	JIS <sup>(2)</sup>
6	Flange	Cast steel low temperature	G20Mn5QT, 10213-3 P285QH+QT, 10222-4 P275NL, 10028-3	A352	G5152
7	Gasket	Fiber non asbestos			
8	Seat	High density polymer			

### ICFC 25 check valve module

Figure 28: ICFC 25 check valve module

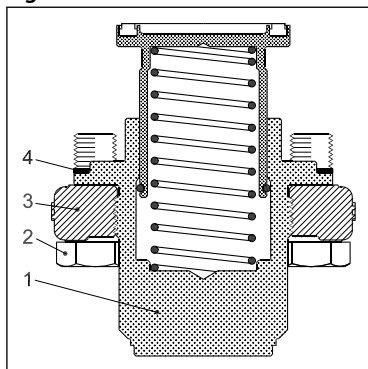

Table 53: ICFC 25 check valve module

Pos.	Part	Material	EN <sup>(1)</sup>	ASTM <sup>(2)</sup>	JIS <sup>(2)</sup>
1	Bonnet	Steel	S355J2+N 1.0570 / 1.0577 EN 10025-2	ASTM A572-50	
2	Hex-head bolt M12 × 30	Stainless steel	A2-70 EN 24017	A320	A2-70
3	Flange	Cast steel low temperature	G20Mn5QT, 10213-3 P285QH+QT, 10222-4 P275NL, 10028-3	A352	AG5152
4	Gasket	Fiber non asbestos			

### ICFN 25 stop & check valve module

Figure 29: ICFN 25 stop & check valve module

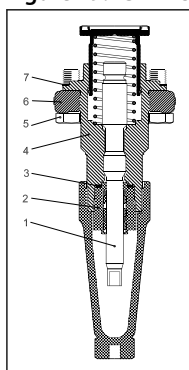

Table 54: ICFN 25 stop & check valve module

Pos.	Part	Material	EN <sup>(1)</sup>	ASTM <sup>(2)</sup>	JIS <sup>(2)</sup>
1	Spindle	Stainless steel	X8CrNiS 18-9 EN 10088		G4303 G4304
2	Thread part	Stainless steel	X8CrNiS 18-9 EN 10088		G4303 G4304
3	O-ring	Chloroprene			
4	Bonnet	Steel	S355J2+N 1.0570 / 1.0577 EN 10025-2	ASTM A572-50	



## Valve station, type ICF 15, ICF 20, ICF 25, ICF 50 and ICF 65

Pos.	Part	Material	EN <sup>(1)</sup>	ASTM <sup>(2)</sup>	JIS <sup>(2)</sup>
5	Hex-head bolt M12 × 30	Stainless steel	A2-70 EN 24017	A320	A2-70
6	Flange	Cast steel low temperature	G20Mn5QT, 10213-3 P285QH+QT, 10222-4 P275NL, 10028-3	A352	G5152
7	Gasket	Fiber non asbestos			

### ICM 25-A or B motor operated valve module

Figure 30: ICM 25-A or B motor operated valve module

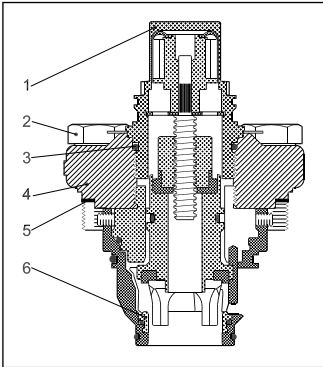

Table 55: ICM 25-A or B motor operated valve module

Pos.	Part	Material	EN <sup>(1)</sup>	ASTM <sup>(2)</sup>	JIS <sup>(2)</sup>
1	Adapter	Stainless steel	X5CrNi18-10 EN 10088	A240	G4303 G4304
2	Hex-head bolt M12 × 30	Stainless steel	A2-70 EN 24014	A320	A2-70
3	O-ring	Chloroprene			
4	Bonnet	Cast steel low temperature	G20Mn5QT EN 10213-3	A352	G5152
5	Gasket	Fiber non asbestos			
6	Seat	High density polymer			

### ICFB 25 blind top cover

Figure 31: ICFB 25 blind top cover

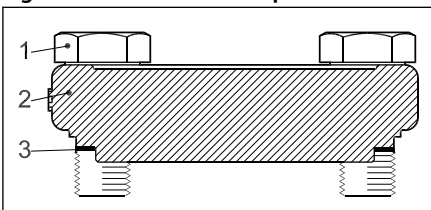

Table 56: ICFB 25 blind top cover

Pos.	Part	Material	EN <sup>(1)</sup>	ASTM <sup>(2)</sup>	JIS <sup>(2)</sup>
1	Hex-head bolt M10 × 25	Stainless Steel	A2-70 EN 24017	A320	A2-70
2	Flange	Cast steel low temperature	G20Mn5QT, 10213-3 P285QH+QT, 10222-4	A352	G5152
3	Gasket	Fiber non asbestos			

### ICFW 25 welding module, 25 DIN or 25 (1") SOC

Figure 32: ICFW 25 welding module, 25 DIN or 25 (1") SOC

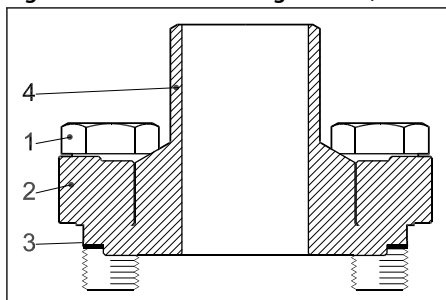

Table 57: ICFW 25 welding module, 25 DIN or 25 (1") SOC

Pos.	Part	Material	EN <sup>(1)</sup>	ASTM <sup>(2)</sup>	JIS <sup>(2)</sup>
1	Hex-head bolt M10 × 25	Stainless Steel	A2-70 EN 24017	A320	A2-70
2	Flange	Cast steel low temperature	G20Mn5QT, 10213-3 P285QH+QT, 10222-4	A352	G5152
3	Gasket	Fiber non asbestos			
4	Weld connection	Steel	S355J2+N EN 10025-2	A572-50	G3106 SM49

### SVA-S 50 / SVA-S 65 shut-off valve module

Figure 33: SVA-S 50 / SVA-S 65 shut-off valve module

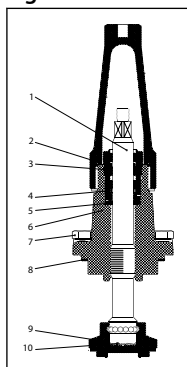

Table 58: SVA-S 50 / SVA-S 65 shut-off valve module

Pos.	Part	Material	EN <sup>(1)</sup>	ASTM <sup>(2)</sup>
1	Spindle	Stainless steel	X8CrNiS18-9 10088	AISI 303
2	Gasket for cap	Nylon		
3	Packing gland	Stainless steel	X8CrNiS18-9 10088	AISI 303
4	Spring loaded Teflon ring	PTFE		
5	Packing washer	Aluminium		
6	Bonnet	Steel	P285QH+QT, EN 10222-4	LF2, A350
7	Bolts	Stainless steel	A2-70	Type 308
8	Gasket	Fiber, non asbestos		
9	Cone	Steel	11SMn30 10087	AISI 1213
10	Disk spring	Steel		

## REG-SB 50 / REG-SB 65 manual regulating valve module

Figure 34: REG-SB 50 / REG-SB 65 manual regulating valve module

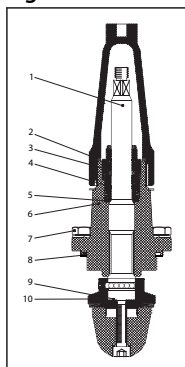

Table 59: REG-SB 50 / REG-SB 65 manual regulating valve module

Pos.	Part	Material	EN <sup>(1)</sup>	ASTM <sup>(2)</sup>
1	Spindle	Stainless steel	X8CrNiS 18-9 17440	AISI 303
2	Gasket for cap	Nylon		
3	Packing gland	Stainless Steel	X8CrNiS 18-9 10088	AISI 303
4	Spring loaded Teflon ring	PTFE		
5	Packing washer	Aluminium		
6	Bonnet	Steel	P285QH+QT 10222-4	LF2 A350
7	Bolts	Stainless steel	A2-70	Type 308
8	Gasket	Fiber, non asbestos		
9	Disk spring	Steel		
10	Cone	Steel		

## ICFB 50 blind top cover

Figure 35: ICFB 50 blind top cover

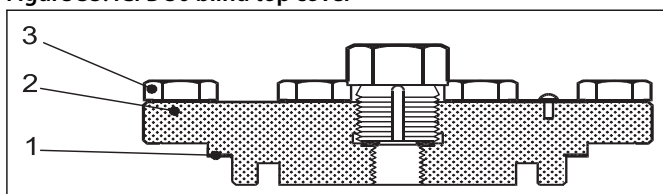

Table 60: ICFB 50 blind top cover

Pos.	Part	Material	EN <sup>(1)</sup>	ASTM <sup>(2)</sup>	JIS <sup>(2)</sup>
1	Gasket	Fiber non asbestos			
2	Flange	Cast steel low temperature	G20Mn5QT, 10213-3 P285QH+QT, 10222-4	A352	G5152
3	Hex-head bolt M10 × 25	Stainless Steel	A2-70 EN 24017	A320	A2-70

## ICS 50 / ICS 65 pilot-operated valve module

Figure 36: ICS 50 / ICS 65 pilot-operated valve module

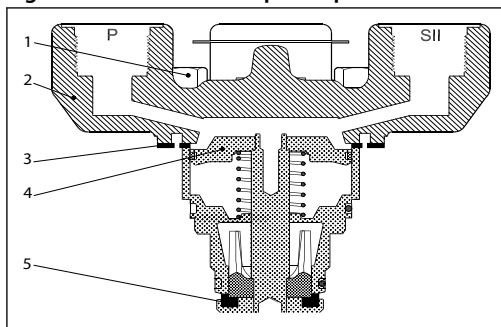

Table 61: ICS 50 / ICS 65 pilot-operated valve module

Pos.	Part	Material	EN <sup>(1)</sup>	ASTM <sup>(2)</sup>
1	Bolts	Stainless steel	A2-70 EN 1515-1	Grade B8 A320
2	Bonnet	Low temperature steel	G20Mn5QT EN 10213-3 P285QH+QT EN 10222-4	LCC A352 LF2 A350
3	Gasket	Fiber, non-asbestos		
4	Piston	Steel		
5	Valve plate	PTFE		

## ICM 50 / ICM 65 motor operated valve module

Figure 37: ICM 50 / ICM 65 motor operated valve module

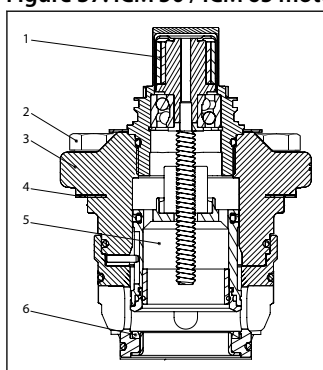

Table 62: ICM 50 / ICM 65 motor operated valve module

Pos.	Part	Material	EN <sup>(1)</sup>	ASTM <sup>(2)</sup>
1	Adaptor	Stainless steel	X5CrNi18-10 EN 10088	A240
2	Bolts	Stainless steel	A2-70 EN 1515-1	Grade B8 A320
3	Bonnet	Low temperature steel	G20Mn5QT EN 10213-3	LCC A352
4	Gasket	Fiber, non-asbestos		
5	Piston	Steel		
6	Valve plate	PTFE		

## ICLX 50 / ICLX 65 2-step solenoid valve module

Figure 38: ICLX 50 / ICLX 65 2-step solenoid valve module

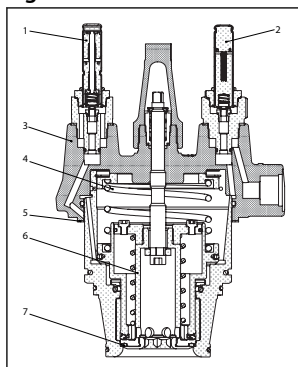

Table 63: ICLX 50 / ICLX 65 2-step solenoid valve module

Pos.	Part	Material	EN <sup>(1)</sup>	ASTM <sup>(2)</sup>
1	EVM pilot NO			
2	EVM pilot NC			
3	Bonnet	Low temperature steel	P285QH EN 10222-4	LF2 A350
4	Spring	Stainless steel		
5	Gasket	Fiber, non-asbestos		
6	Main piston	Steel		
7	Seat plate main	PTFE		

## ICSH 50 / ICSH 65 2-step solenoid valve module

Figure 39: ICSH 50 / ICSH 65 2-step solenoid valve module

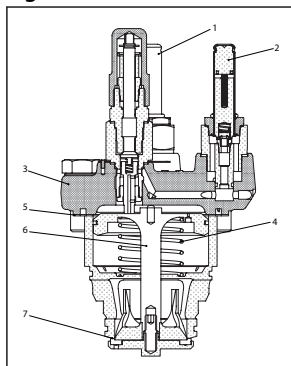

Table 64: ICSH 50 / ICSH 65 2-step solenoid valve module

Pos.	Part	Material	EN <sup>(1)</sup>	ASTM <sup>(2)</sup>
1	EVM pilot NC			
2	EVM pilot NC			
3	Bonnet	Low temperature steel	P285QH EN 10222-4	LF2 A350
4	Spring	Stainless steel		
5	Gasket	Fiber, non-asbestos		
6	Main piston	Steel		
7	Seat plate main	PTFE		

<sup>(1)</sup> Primary Design Standard

<sup>(2)</sup> Equivalent Material Standard

## Connections

There is a wide range of connection types and sizes available with ICF valve stations:

## Valve station, type ICF 15, ICF 20, ICF 25, ICF 50 and ICF 65

- **D**: Butt weld, DIN (EN 10220)
- **A**: Butt weld, ANSI (ASME B 36.10M SCHEDULE 80)
- **A**: Butt weld, ANSI (ASME B 36.19 SCHEDULE 40)
- **SOC**: Socket weld, ANSI (B 16.11)
- **SA**: Soldering/Brazing ASME (ASME B16.22/B16.50)
- **SD**: Soldering/Brazing DIN (DIN EN 1254-5)

Figure 40:

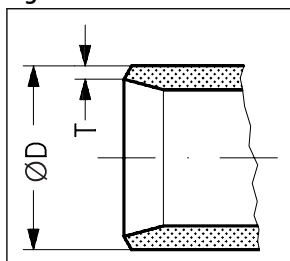

Table 65: D: Butt-weld DIN (EN 10220)

Size	Size	ØD	T	ØD	T
mm	in.	mm	mm	in.	in.
15	½	21.3	1.3	0.839	0.052
20	¾	26.9	2.3	1.059	0.091
25	1	33.7	2.6	1.327	0.103
32	1 ¼	42.4	2.6	1.669	0.102
40	1 ½	48.3	2.6	1.902	0.103
50	2	60.3	2.9	2.37	0.11
65	2 ½	76.1	2.9	3	0.11
80	3	88.9	3.2	3.5	0.13

Figure 41:

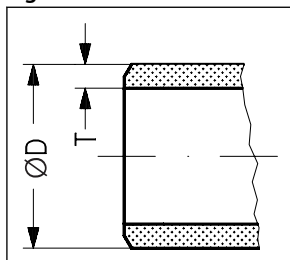

Table 66: A: Butt-weld ANSI (B 36.10), Butt weld ANSI (B 36.19)

Size	Size	ØD	T	ØD	T	Schedule
mm	in.	mm	mm	in.	in.	
15	½	21.3	2.7	0.839	0.105	80
20	¾	26.9	4	1.059	0.158	80
25	1	33.7	4.6	1.327	0.181	80
32	1 ¼	42.4	4.9	1.669	0.193	80
40	1 ½	48.3	5.1	1.902	0.201	80
65	2 ½	73	5.2	2.87	0.2	40
80	3	88.9	5.5	3.5	0.22	40

Figure 42:

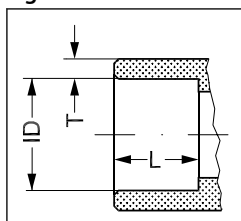

Table 67: SOC: Socket welding ANSI (B 16.11)

Size	Size	ID	T	ID	T	L	L
mm	in.	mm	mm	in.	in.	mm	in.
15	1/2	21.9	5.9	0.862	0.232	10.25	0.4
20	3/4	27.2	4.6	1.071	0.181	13	0.51
25	1	33.9	7.2	1.335	0.284	13	0.51
32	1 1/4	42.7	6.1	1.743	0.24	13	0.51
40	1 1/2	48.8	6.6	1.921	0.26	13	0.51
50	2	61.2	6.2	2.41	0.24	16	0.63

Figure 43:

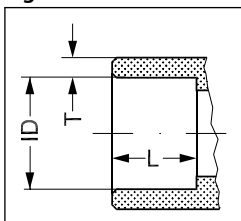

Table 68: SD: Soldering/Brazing (DIN EN 1254-5)

Size	ID	L
mm	mm	mm
22	22.08	16.5

Figure 44:

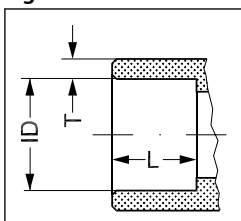

Table 69: SA: Soldering/Brazing (ASME B16.22/B16.50)

Size	ID	L
in.	in.	in.
7/8	0.875	0.65

Figure 45:

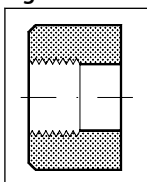

Table 70: FPT: Female pipe thread, (ANSI/ASME B 1.20.1)

Size	Size	Inside pipe thread
mm	in.	
15	1/2	(1/2 x 14 NPT)

**Dimensions and weights**

**ICF 15-4**

Figure 46: ICF 15-4

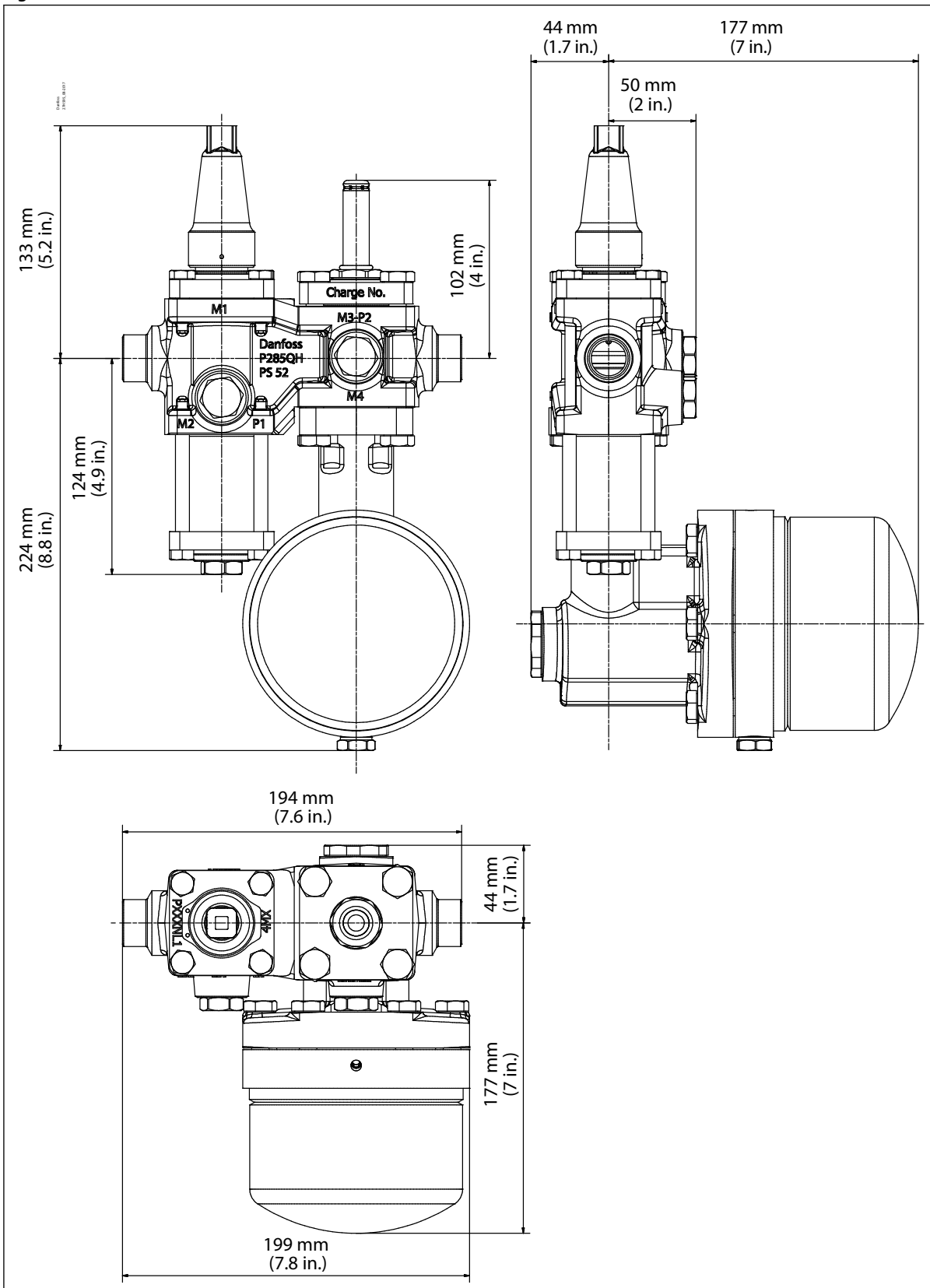



**NOTE:**

This example indicates the maximum dimensions for the ICF valve stations.

Figure 47: ICF 15-4

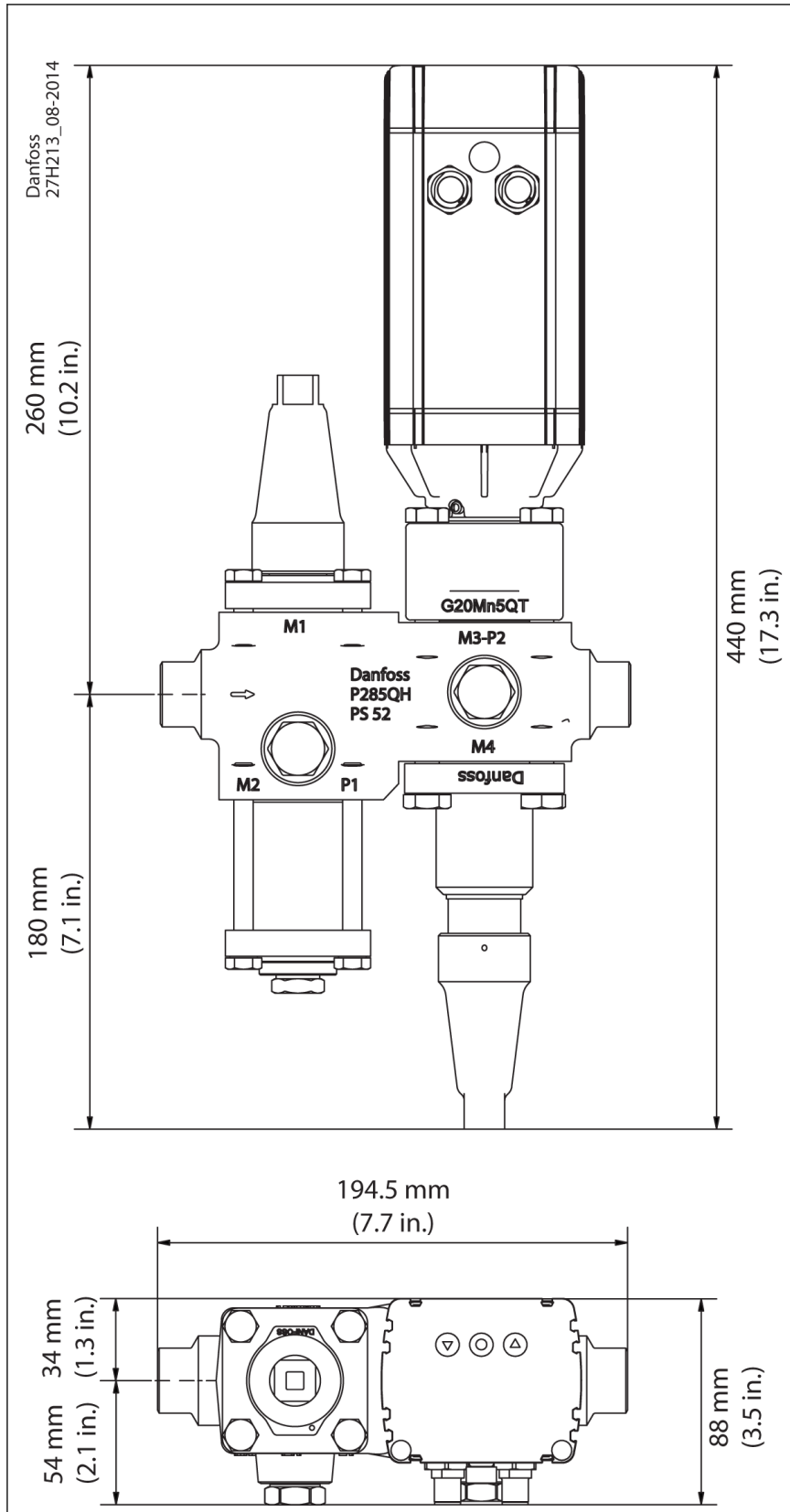

**NOTE:**

This example indicates the maximum dimensions for the ICF valve stations.

ICF 20-2

Figure 48: ICF 20-2

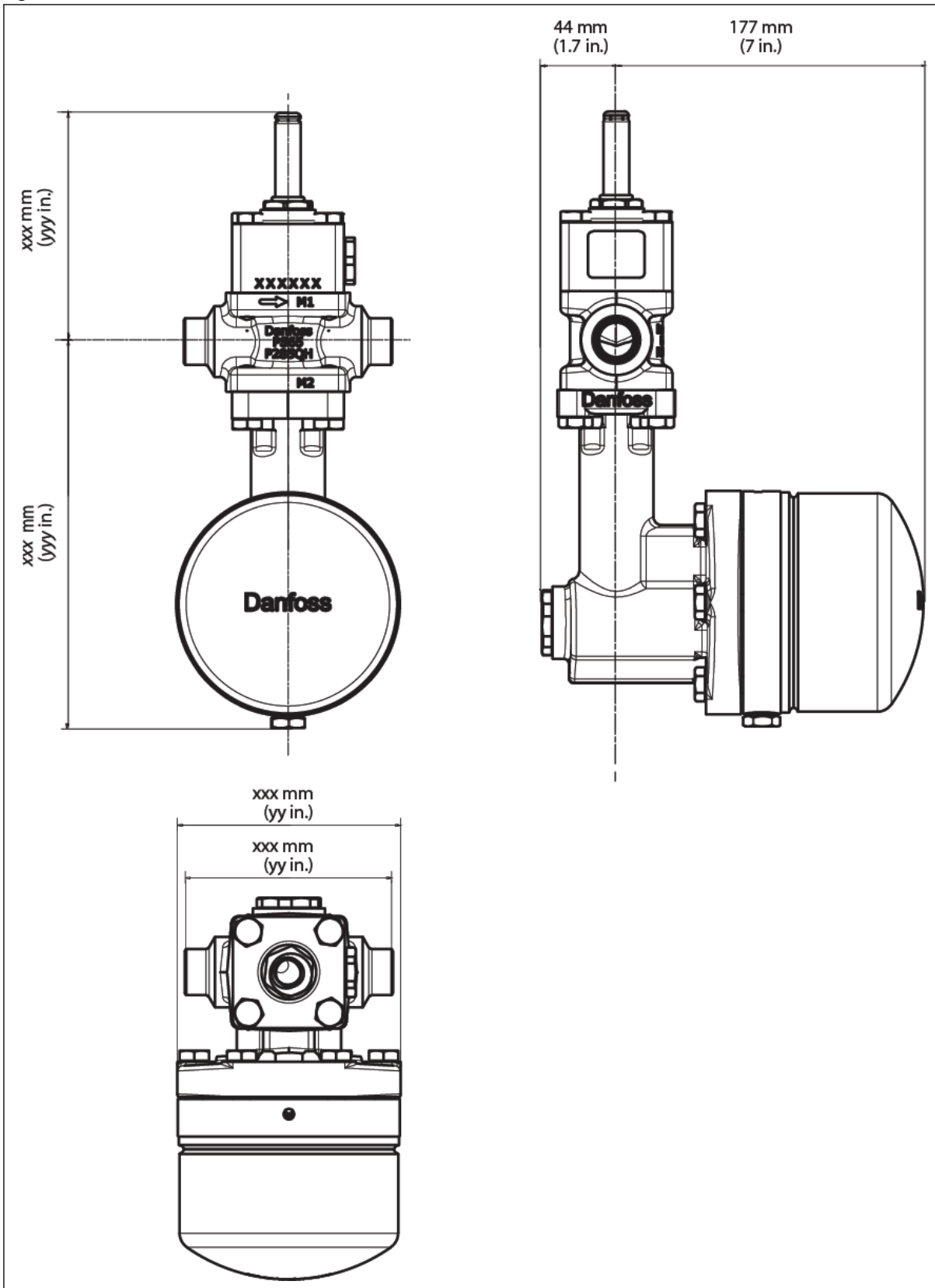

**NOTE:**

This example indicates the maximum dimensions for the ICF valve stations.

ICF 20-4

Figure 49: ICF 20-4

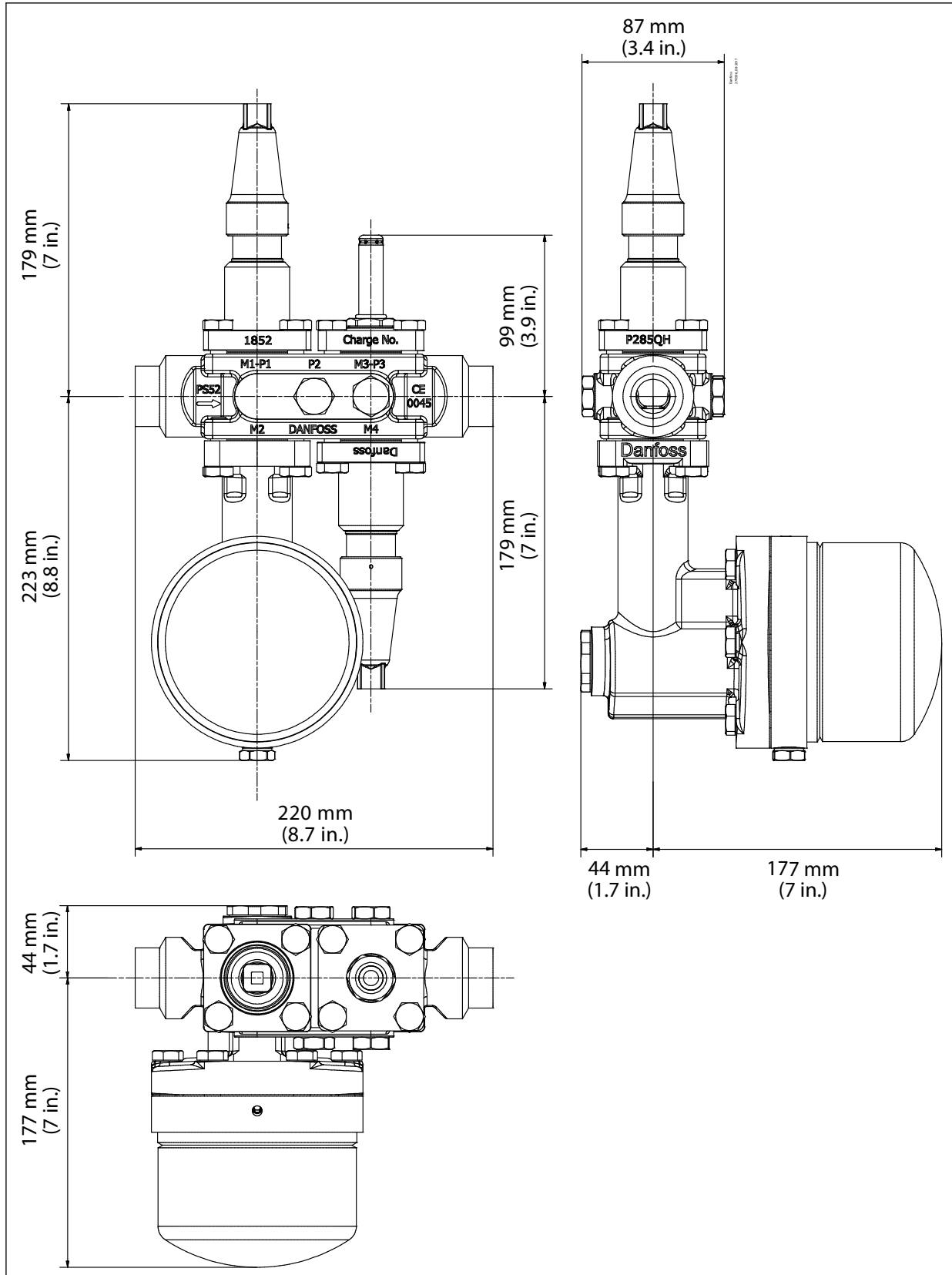

**NOTE:** This example indicates the maximum dimensions for the ICF valve stations.

Figure 50: ICF 20-4

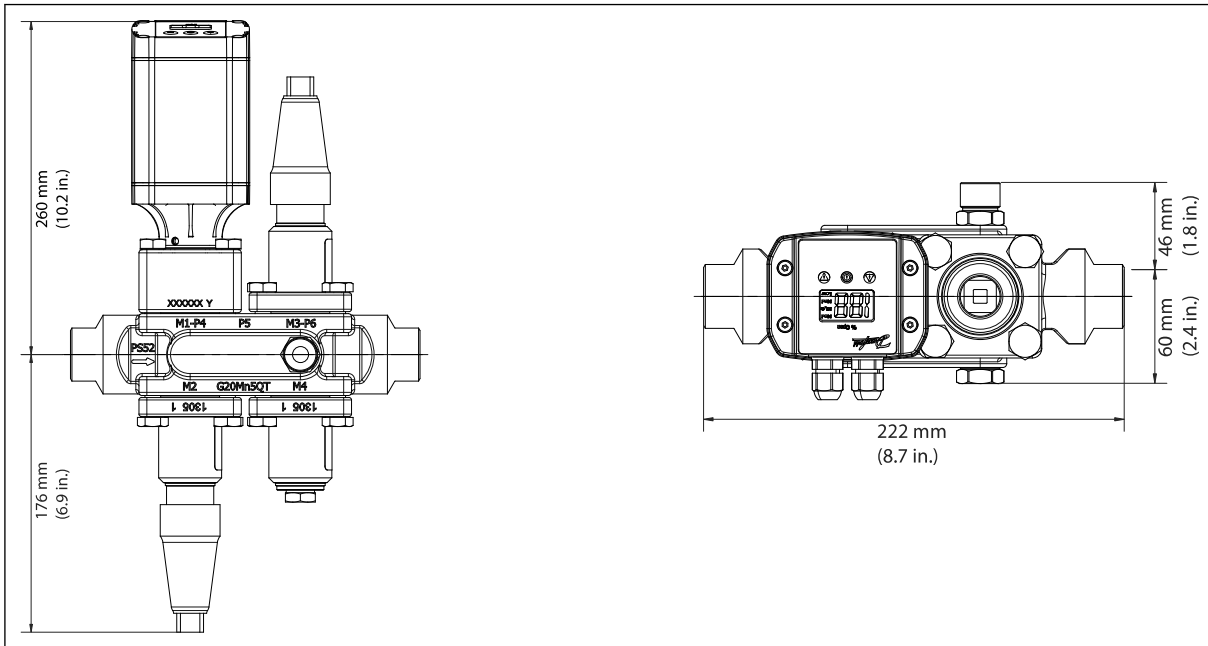

**NOTE:**

This example indicates the maximum dimensions for the ICF valve stations.

ICF 20-6

Figure 51: ICF 20-6

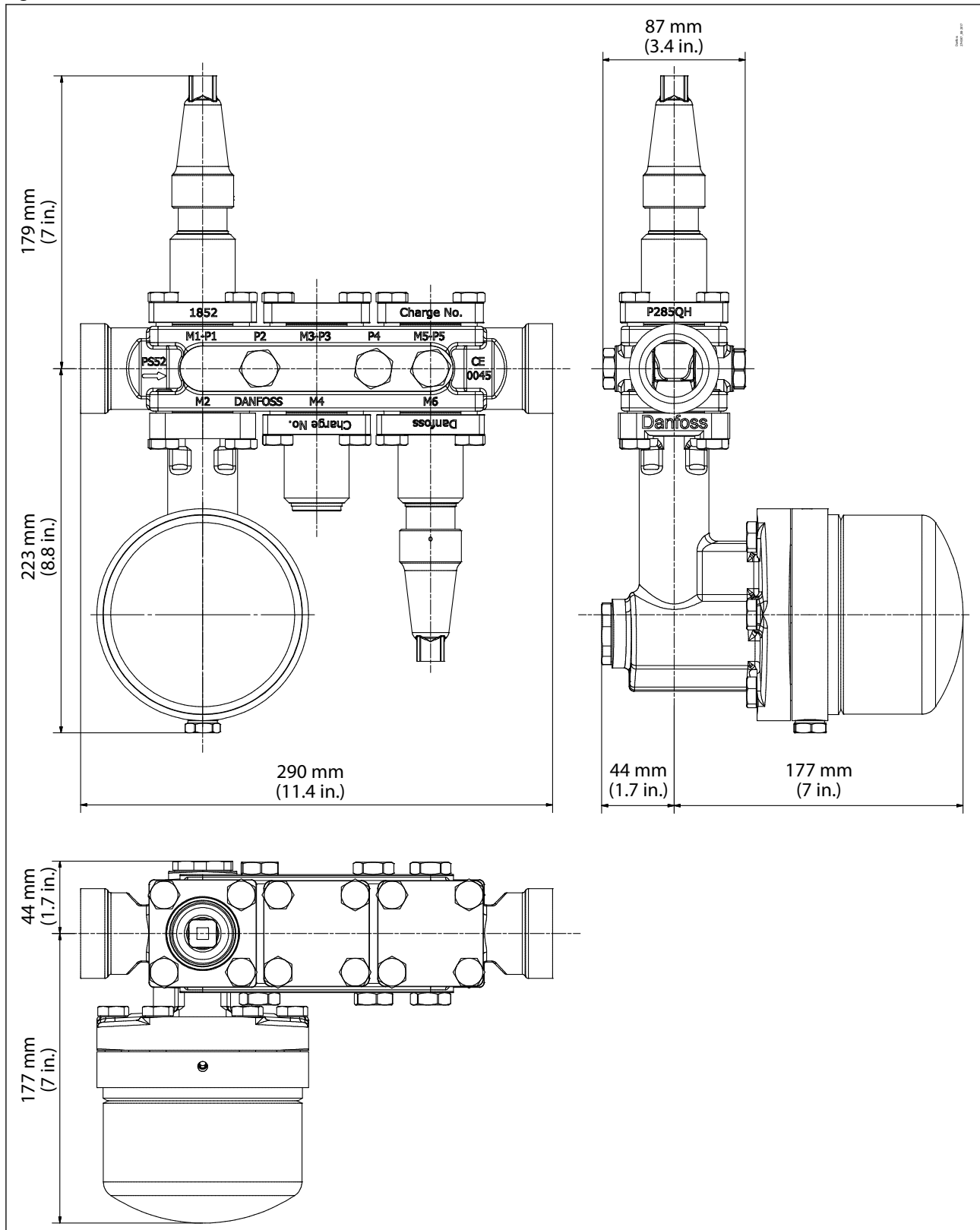

**NOTE:**

This example indicates the maximum dimensions for the ICF valve stations.

Figure 52: ICF 20-6

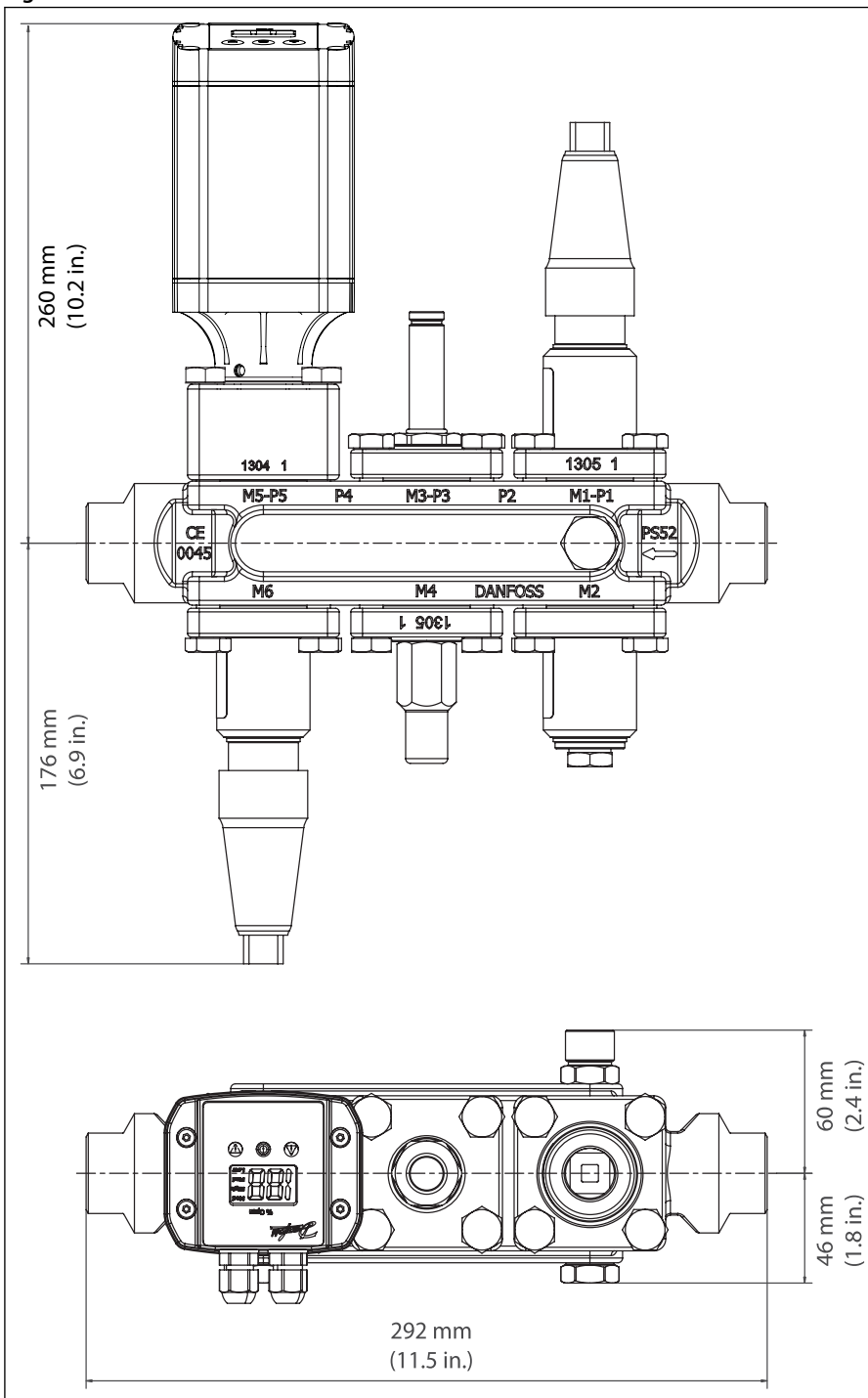

**NOTE:**

This example indicates the maximum dimensions for the ICF valve stations.

ICF 25-4

Figure 53: ICF 25-4

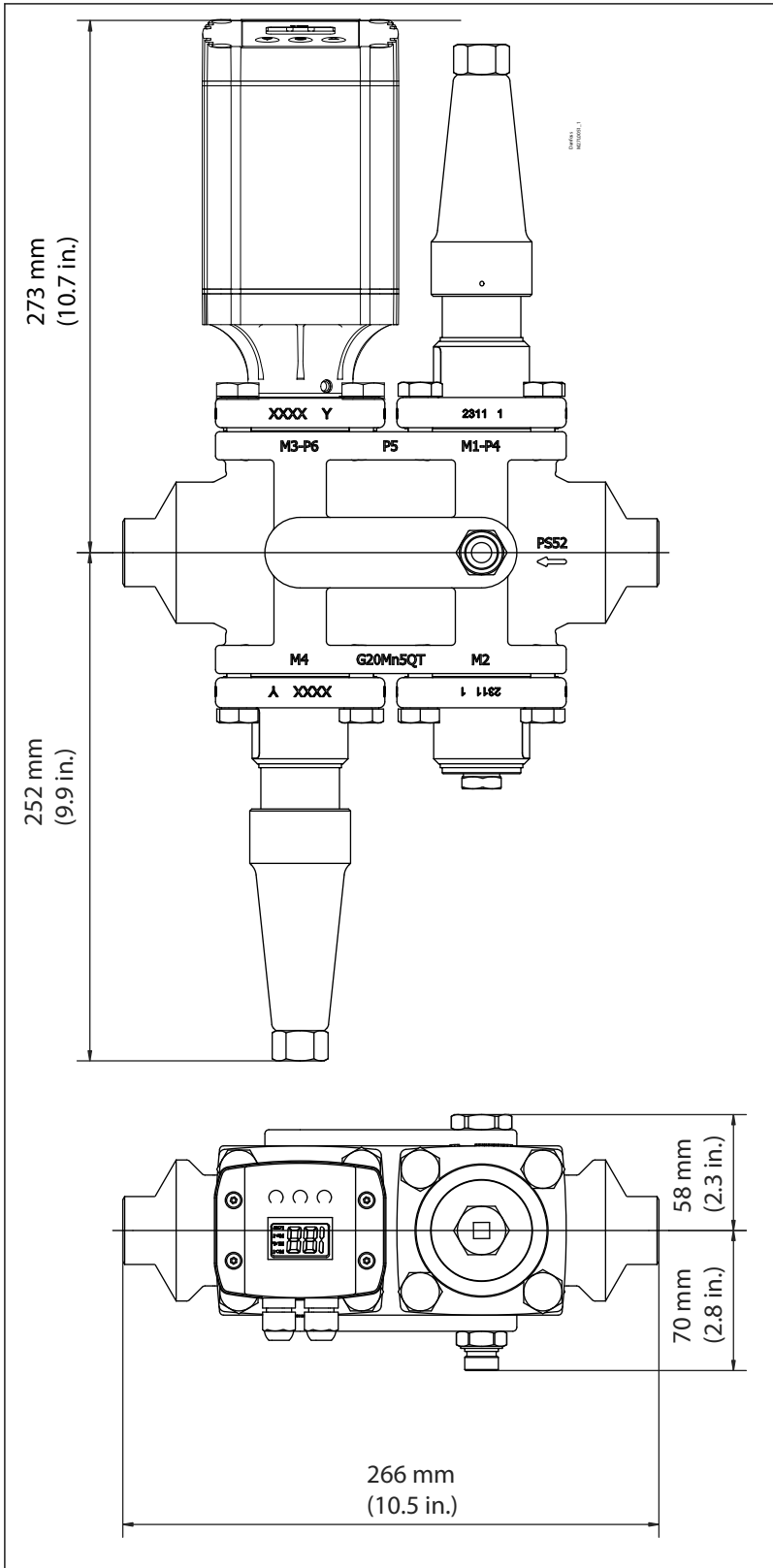

**NOTE:**

This example indicates the maximum dimensions for the ICF valve stations.

ICF 25-6

Figure 54: ICF 25-6

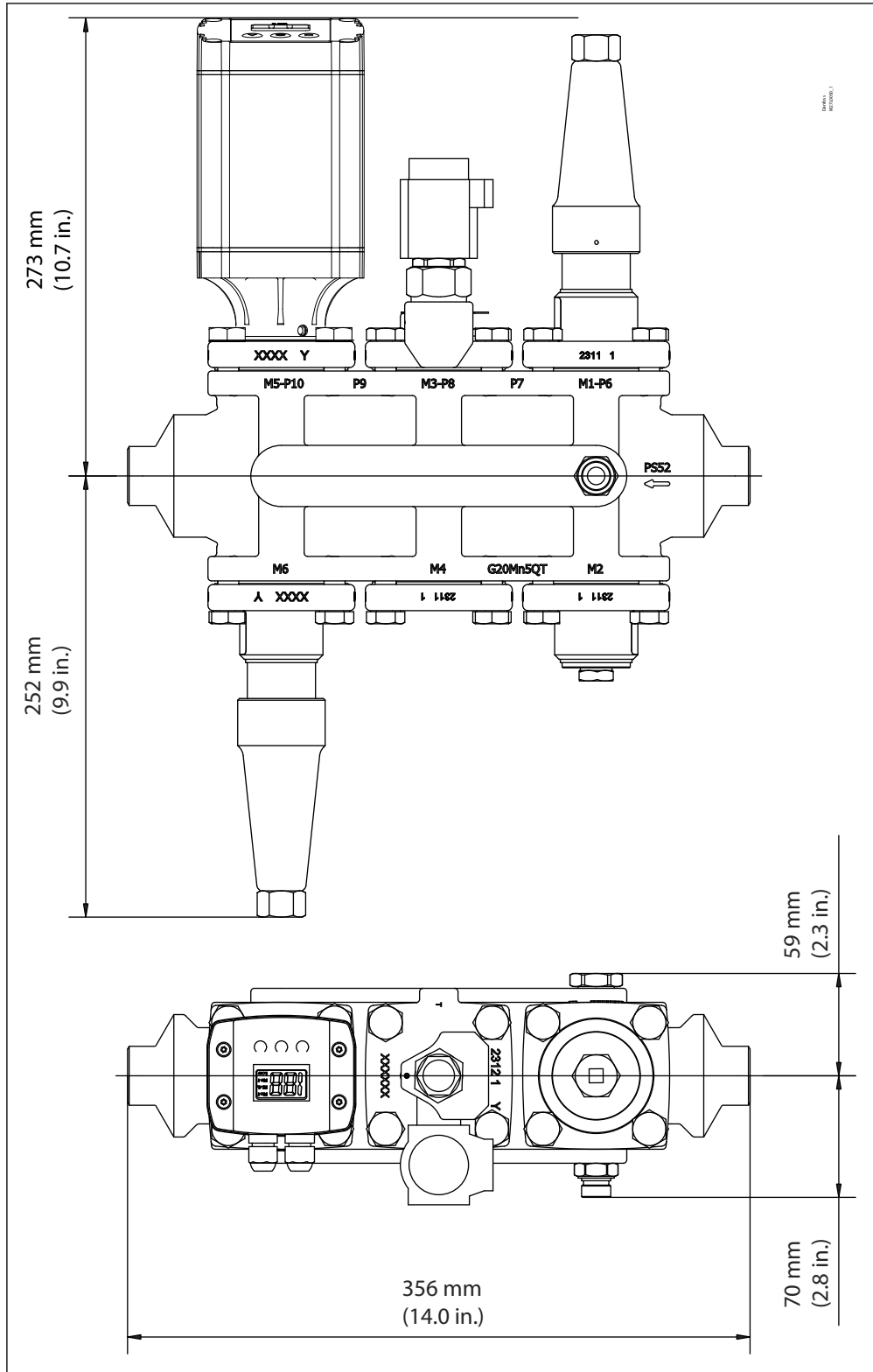

**NOTE:**  
This example indicates the maximum dimensions for the ICF valve stations.



ICF 50-4

Figure 55: ICF 50-4

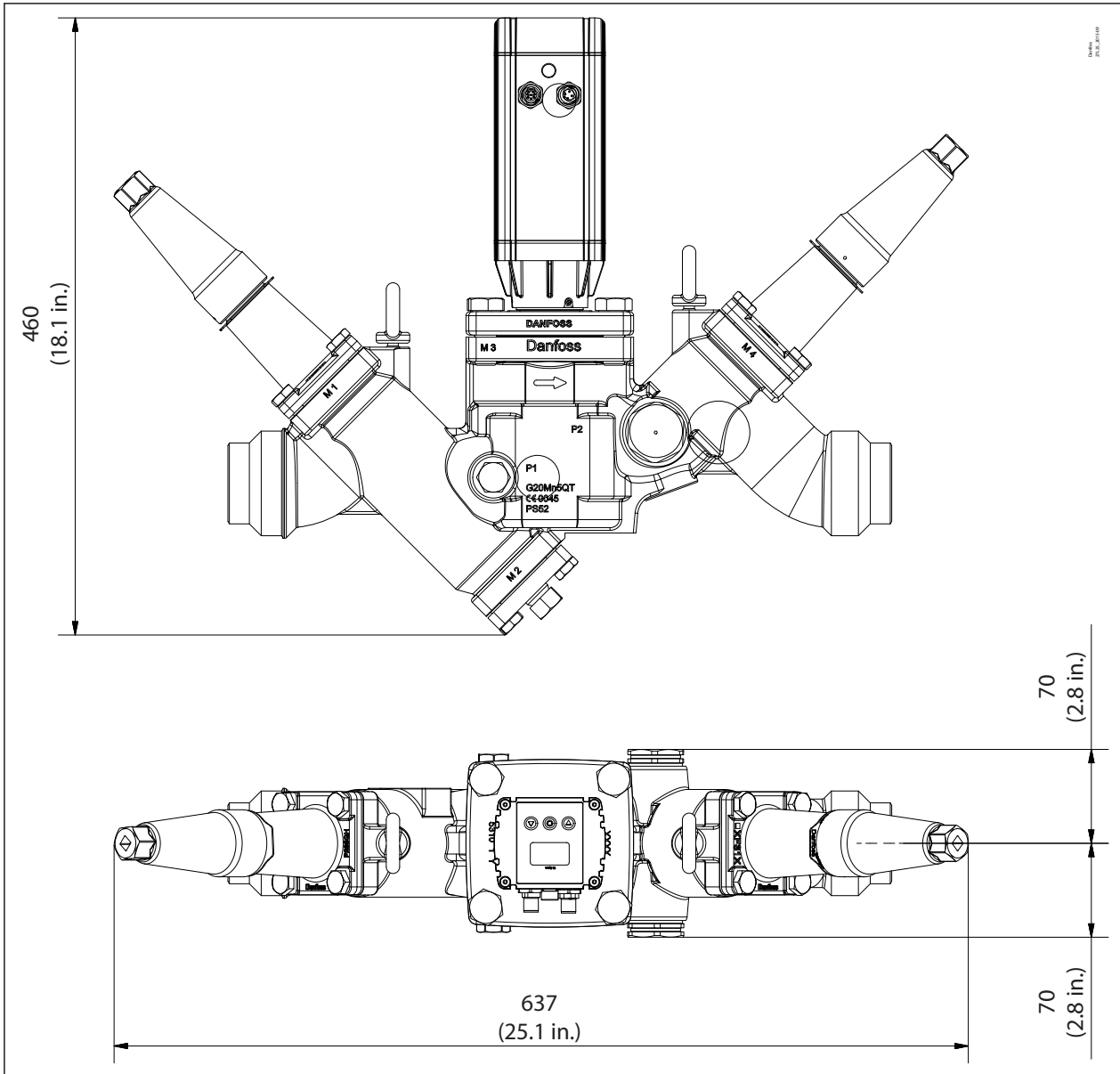

**i** NOTE:

This example indicates the maximum dimensions for the ICF valve stations.

ICF 65-3

Figure 56: ICF 65-3

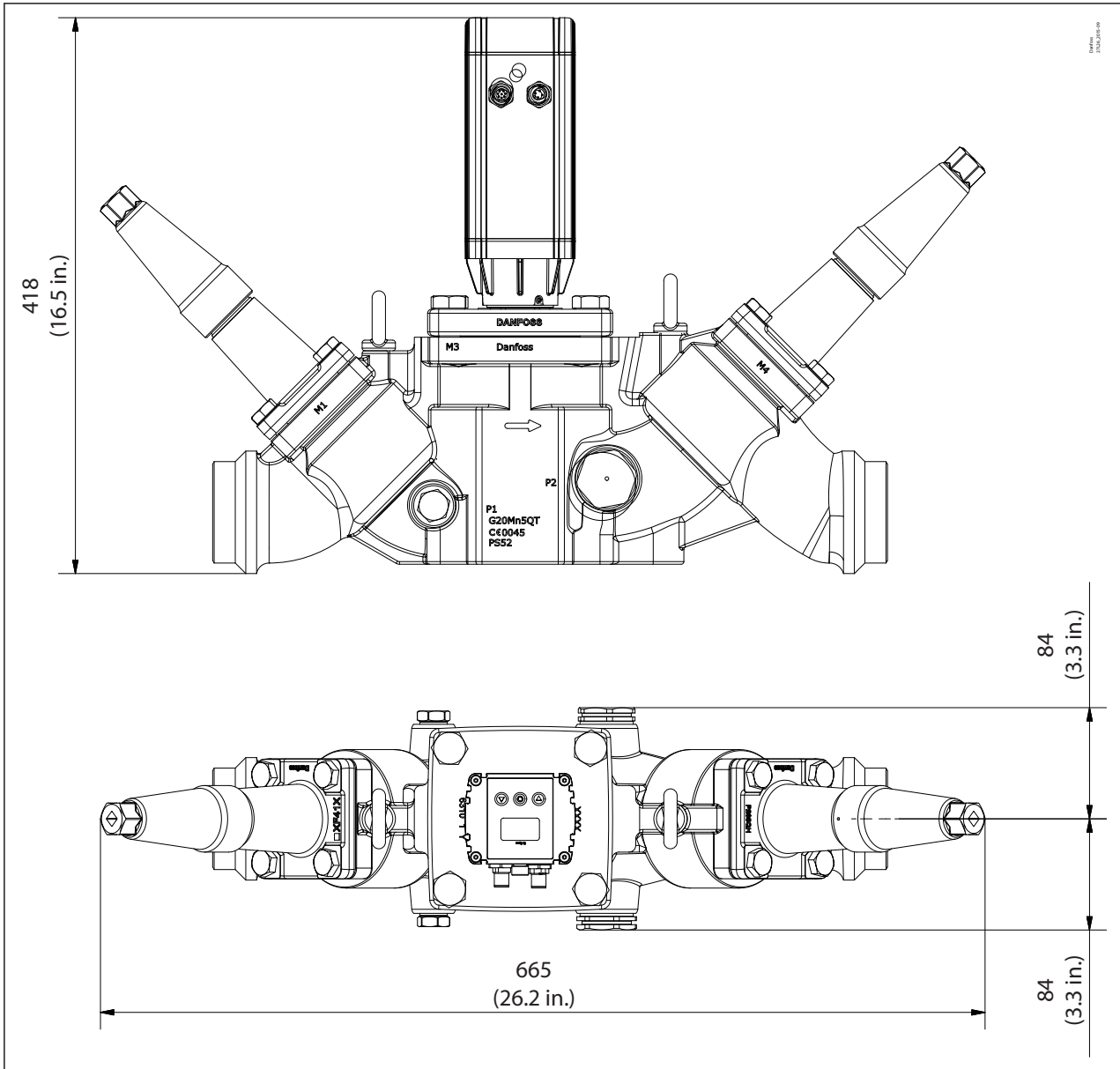

**NOTE:**

This example indicates the maximum dimensions for the ICF valve stations.

## Ordering

### Code number selection

To determine the correct ICF valve station follow steps 1 through 5.

#### Step 1

##### **Determine application and function requirements:**

- Line: Pumped liquid, Liquid Injection, Hot gas defrost, Liquid DX, Return line etc.
- Control: On/off solenoid valve, motorised valve
- Defrost: Electric or hot gas

##### **NOTE:**

From the above determine the application reference number (see [Page 52](#))

#### Step 2

##### **Selection criteria - (Please use Danfoss calculation software)**

Download the software from: [Coolselector<sup>®2</sup>](#)

- Refrigerant
- Capacity
- Temperature
- Circulation rate

##### **NOTE:**

From the above determine the valve station required, e.g.: ICF 20 complete with ICM 20-C

#### Step 3

##### **Establish connection sizes and type**

- DIN butt-weld, ANSI butt-weld or SOC weld
- 15 (½ in.), 20 (¾ in.), 25 (1 in.), 32 (1 ¼ in.) or , 40 (1½ in.), 50 (2 in.), 65 (2½ in.) or 80 (3 in.)

#### Step 4

##### **Establish code number**

##### **NOTE:**

(see [Page 52](#) to [Page 75](#))

## Ordering ICF valve station

Below Nomenclature show the generic configuration and application by identification of housing size, type and application group.

This designation is often used for discussion on possible solutions and will be the final identification on the valve label (see label example)

Figure 57: Ordering ICF valve station

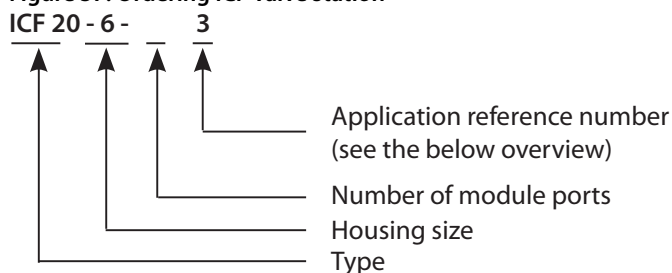

Figure 58: Label example



For ordering, connection size and type must be chosen to get the final identification. **The final identification is done by code number only** (see next pages)

**NOTE:**

**Applicable for all sizes and configurations.**

ICAD and coils are not included and must be ordered separately.

When used in systems with CO<sub>2</sub>, the o-rings on the ICM module can swell (grow). At service, it is therefore recommended to install new o-rings, before the ICM function module is re-installed in the ICF.

## Liquid feed

Table 71: Application 1: Liquid feed (no hot gas defrost)

Type	# of modules	Appl. #	Connection size		Connection type	Module location						Weight		Code number
			[in.]	[mm]		M1	M2	M3	M4	M5	M6	kg	lbs	
ICF 20	6	1RA	3/4	20	Butt-weld ANSI (B 36.10)	ICFS 20	ICFF 20	ICFE 20	ICFO 20	ICFR 20A	ICFS 20	9.5	20.9	027L3004
ICF 20	6	1RA	1	25	Butt-weld ANSI (B 36.10)	ICFS 20	ICFF 20	ICFE 20	ICFO 20	ICFR 20A	ICFS 20	10.1	22.2	027L3373
ICF 25	6	1RB	1 1/4	32	Butt-weld ANSI (B 36.10)	ICFS 25	ICFF 25	ICFE 25	ICFB 25	ICFR 25B	ICFS 25	23.8	52.4	027L4012
ICF 20	6	1RA	3/4	20	Butt-weld DIN-EN 10220	ICFS 20	ICFF 20	ICFE 20	ICFO 20	ICFR 20A	ICFS 20	9.5	20.9	027L3000
ICF 20	6	1RA	1	25	Butt-weld DIN-EN 10220	ICFS 20	ICFF 20	ICFE 20	ICFO 20	ICFR 20A	ICFS 20	9.7	21.3	027L3002
ICF 20	6	1HRB	1	25	Butt-weld DIN-EN 10220	ICFS 20	ICFF 20	ICFE 20H	ICFB 20	ICFR 20B	ICFS 20	10.3	22.7	027L3406
ICF 25	6	1RA	1	25	Butt-weld DIN-EN 10220	ICFS 25	ICFF 25	ICFE 25	ICFB 25	ICFR 25A	ICFS 25	23.6	51.9	027L4002
ICF 20	6	1RA	1 1/4	32	Butt-weld DIN-EN 10220	ICFS 20	ICFF 20	ICFE 20	ICFO 20	ICFR 20A	ICFS 20	9.7	21.3	027L3003
ICF 20	6	1HRB	1 1/4	32	Butt-weld DIN-EN 10220	ICFS 20	ICFF 20	ICFE 20H	ICFB 20	ICFR 20B	ICFS 20	10.3	22.7	027L3407
ICF 25	6	1RA	1 1/4	32	Butt-weld DIN-EN 10220	ICFS 25	ICFF 25	ICFE 25	ICFB 25	ICFR 25A	ICFS 25	23.6	51.9	027L4006

## Valve station, type ICF 15, ICF 20, ICF 25, ICF 50 and ICF 65

Type	# of modules	Appl. #	Connection size		Connection type	Module location						Weight		Code number
			[in.]	[mm]		M1	M2	M3	M4	M5	M6	kg	lbs	
ICF 25	6	1RB	1¼	32	Butt-weld DIN-EN 10220	ICFS 25	ICFF 25	ICFE 25	ICFB 25	ICFR 25B	ICFS 25	23.6	51.9	027L4011
ICF 25	6	1RB	1½	40	Butt-weld DIN-EN 10220	ICFS 25	ICFF 25	ICFE 25	ICFB 25	ICFR 25B	ICFS 25	22.7	49.9	027L4016
ICF 20	6	1RA	¾	20	Socket weld, ANSI (B 16.11)	ICFS 20	ICFF 20	ICFE 20	ICFO 20	ICFR 20A	ICFS 20	10.4	22.9	027L3005
ICF 20	6	1RA	1	25	Socket weld, ANSI (B 16.11)	ICFS 20	ICFF 20E	ICFE 20	ICFO 20	ICFR 20A	ICFS 20	9.9	21.8	027L3007
ICF 20	6	1HRB	1	25	Socket weld, ANSI (B 16.11)	ICFS 20	ICFF 20E	ICFE 20H	ICFB 20	ICFR 20B	ICFS 20	10.9	24	027L3408
ICF 25	6	1RA	1	25	Socket weld, ANSI (B 16.11)	ICFS 25	ICFF 25E	ICFE 25	ICFB 25	ICFR 25A	ICFS 25	24.1	53	027L4003
ICF 20	6	1RA	1¼	32	Socket weld, ANSI (B 16.11)	ICFS 20	ICFF 20E	ICFE 20	ICFO 20	ICFR 20A	ICFS 20	10.1	22.2	027L3008
ICF 20	6	1HRB	1¼	32	Socket weld, ANSI (B 16.11)	ICFS 20	ICFF 20E	ICFE 20H	ICFB 20	ICFR 20B	ICFS 20	10.9	24	027L3409
ICF 25	6	1RA	1¼	32	Socket weld, ANSI (B 16.11)	ICFS 25	ICFF 25E	ICFE 25	ICFB 25	ICFR 25A	ICFS 25	23.8	52.4	027L4008
ICF 25	6	1RB	1¼	32	Socket weld, ANSI (B 16.11)	ICFS 25	ICFF 25E	ICFE 25	ICFB 25	ICFR 25B	ICFS 25	24.2	53.2	027L4013
ICF 25	6	1RB	1½	40	Socket weld, ANSI (B 16.11)	ICFS 25	ICFF 25E	ICFE 25	ICFB 25	ICFR 25B	ICFS 25	23.8	52.4	027L4017

**Table 72: Application 2: Liquid feed**

Type	# of modules	Appl. #	Connection size		Connection type	Module location						Weight		Code number
			[in.]	[mm]		M1	M2	M3	M4	M5	M6	kg	lbs	
ICF 20	6	2RA	¾	20	Butt-weld ANSI (B 36.10)	ICFS 20	ICFF 20	ICFE 20	ICFO 20	ICFR 20A	ICFN 20	9.8	21.6	027L3013
ICF 20	6	2RA	¾	20	Butt-weld DIN-EN 10220	ICFS 20	ICFF 20	ICFE 20	ICFO 20	ICFR 20A	ICFN 20	9.7	21.3	027L3009
ICF 20	6	2RB	¾	20	Butt-weld DIN-EN 10220	ICFS 20	ICFF 20	ICFE 20	ICFO 20	ICFR 20B	ICFN 20	10.2	22.9	027L3398
ICF 20	6	2RB	1	25	Butt-weld DIN-EN 10220	ICFS 20	ICFF 20	ICFE 20	ICFO 20	ICFR 20B	ICFN 20	10.2	22.9	027L3422
ICF 20	6	2RA	1	25	Butt-weld DIN-EN 10220	ICFS 20	ICFF 20	ICFE 20	ICFO 20	ICFR 20A	ICFN 20	9.7	21.3	027L3011
ICF 20	6	2HRB	1	25	Butt-weld DIN-EN 10220	ICFS 20	ICFF 20	ICFE 20H	ICFB 20	ICFR 20B	ICFN 20	9.2	20.2	027L3410
ICF 20	6	2RA	1¼	32	Butt-weld DIN-EN 10220	ICFS 20	ICFF 20	ICFE 20	ICFO 20	ICFR 20A	ICFN 20	9.7	21.3	027L3012
ICF 20	6	2HRB	1¼	32	Butt-weld DIN-EN 10220	ICFS 20	ICFF 20	ICFE 20H	ICFB 20	ICFR 20B	ICFN 20	9.2	20.2	027L3411
ICF 25	6	2RA	1¼	32	Butt-weld DIN-EN 10220	ICFS 25	ICFF 25	ICFE 25	ICFB 25	ICFR 25A	ICFN 25	23.3	51.3	027L4135
ICF 20	6	2RA	¾	20	Socket weld, ANSI (B 16.11)	ICFS 20	ICFF 20E	ICFE 20	ICFO 20	ICFR 20A	ICFN 20	10.1	22.2	027L3014

## Valve station, type ICF 15, ICF 20, ICF 25, ICF 50 and ICF 65

Type	# of mod-ules	Appl. #	Conne-ction size		Conne-ction type	Module location						Weight		Code number
			[in.]	[mm]		M1	M2	M3	M4	M5	M6	kg	lbs	
ICF 20	6	2RA	1	25	Socket weld, ANSI (B 16.11)	ICFS 20	ICFF 20E	ICFE 20	ICFO 20	ICFR 20A	ICFN 20	9.9	21.8	027L3016
ICF 20	6	2HRB	1	25	Socket weld, ANSI (B 16.11)	ICFS 20	ICFF 20E	ICFE 20H	ICFB 20	ICFR 20B	ICFN 20	8.8	19.4	027L3412
ICF 20	6	2RA	1¼	32	Socket weld, ANSI (B 16.11)	ICFS 20	ICFF 20E	ICFE 20	ICFO 20	ICFR 20A	ICFN 20	9.9	21.8	027L3017
ICF 20	6	2HRB	1¼	32	Socket weld, ANSI (B 16.11)	ICFS 20	ICFF 20E	ICFE 20H	ICFB 20	ICFR 20B	ICFN 20	10.9	24	027L3413

**Table 73: Application 3: Liquid feed**

Type	# of mod-ules	Appl. #	Conne-ction size		Conne-ction type	Module location						Weight		Code number
			[in.]	[mm]		M1	M2	M3	M4	M5	M6	kg	lbs	
ICF 20	6	3RA	¾	20	Butt-weld ANSI (B 36.10)	ICFS 20	ICFF 20	ICFE 20	ICFC 20	ICFR 20A	ICFS 20	9.9	21.8	027L3022
ICF 20	6	3RA	1	25	Butt-weld ANSI (B 36.10)	ICFS 20	ICFF 20	ICFE 20	ICFC 20	ICFR 20A	ICFS 20	9.9	21.8	027L3419
ICF 20	6	3RA	¾	20	Butt-weld DIN-EN 10220	ICFS 20	ICFF 20	ICFE 20	ICFC 20	ICFR 20A	ICFS 20	9.6	21.1	027L3018
ICF 20	6	3RB	¾	20	Butt-weld DIN-EN 10220	ICFS 20	ICFF 20	ICFE 20	ICFC 20	ICFR 20B	ICFS 20	10.4	22.9	027L3433
ICF 20	6	3RA	1	25	Butt-weld DIN-EN 10220	ICFS 20	ICFF 20E	ICFE 20	ICFC 20	ICFR 20A	ICFS 20	10	22	027L3437
ICF 20	6	3HRB	1	25	Butt-weld DIN-EN 10220	ICFS 20	ICFF 20	ICFE 20H	ICFC 20	ICFR 20B	ICFS 20	10.6	23.3	027L3414
ICF 25	6	3RA	1	25	Butt-weld DIN-EN 10220	ICFS 25	ICFF 25	ICFE 25	ICFC 25	ICFR 25A	ICFS 25	23.4	51.5	027L4020
ICF 20	6	3RA	1¼	32	Butt-weld DIN-EN 10220	ICFS 20	ICFF 20	ICFE 20	ICFC 20	ICFR 20A	ICFS 20	10.4	22.9	027L3021
ICF 20	6	3HRB	1¼	32	Butt-weld DIN-EN 10220	ICFS 20	ICFF 20	ICFE 20H	ICFC 20	ICFR 20B	ICFS 20	10.6	23.3	027L3415
ICF 25	6	3RA	1¼	32	Butt-weld DIN-EN 10220	ICFS 25	ICFF 25	ICFE 25	ICFC 25	ICFR 25A	ICFS 25	23.2	51	027L4024
ICF 20	6	3RB	1¼	32	Butt-weld DIN-EN 10220	ICFS 20	ICFF 20	ICFE 20	ICFC 20	ICFR 20B	ICFS 20	10.4	22.9	027L3430
ICF 25	6	3RB	1¼	32	Butt-weld DIN-EN 10220	ICFS 25	ICFF 25	ICFE 25	ICFC 25	ICFR 25B	ICFS 25	23.8	52.4	027L4029
ICF 25	6	3RB	1½	40	Butt-weld DIN-EN 10220	ICFS 25	ICFF 25	ICFE 25	ICFC 25	ICFR 25B	ICFS 25	24	52.8	027L4034
ICF 20	6	3RA	¾	20	Socket weld, ANSI (B 16.11)	ICFS 20	ICFF 20E	ICFE 20	ICFC 20	ICFR 20A	ICFS 20	10	22	027L3023
ICF 20	6	3HRB	¾	20	Socket weld, ANSI (B 16.11)	ICFS 20	ICFF 20E	ICFE 20H	ICFC 20	ICFR 20B	ICFS 20	10.7	23.5	027L3418
ICF 20	6	3RA	1	25	Socket weld, ANSI (B 16.11)	ICFS 20	ICFF 20E	ICFE 20	ICFC 20	ICFR 20A	ICFS 20	10	22	027L3025
ICF 20	6	3HRB	1	25	Socket weld, ANSI (B 16.11)	ICFS 20	ICFF 20E	ICFE 20H	ICFC 20	ICFR 20B	ICFS 20	11.2	24.6	027L3416

## Valve station, type ICF 15, ICF 20, ICF 25, ICF 50 and ICF 65

Type	# of modules	Appl. #	Connection size		Connection type	Module location						Weight		Code number
			[in.]	[mm]		M1	M2	M3	M4	M5	M6	kg	lbs	
ICF 25	6	3RA	1	25	Socket weld, ANSI (B 16.11)	ICFS 25	ICFF 25E	ICFE 25	ICFC 25	ICFR 25A	ICFS 25	24.2	53.2	027L4021
ICF 20	6	3RA	1¼	32	Socket weld, ANSI (B 16.11)	ICFS 20	ICFF 20E	ICFE 20	ICFC 20	ICFR 20A	ICFS 20	10.1	22.2	027L3026
ICF 20	6	3HRB	1¼	32	Socket weld, ANSI (B 16.11)	ICFS 20	ICFF 20E	ICFE 20H	ICFC 20	ICFR 20B	ICFS 20	11.3	24.9	027L3417
ICF 25	6	3RA	1¼	32	Socket weld, ANSI (B 16.11)	ICFS 25	ICFF 25E	ICFE 25	ICFC 25	ICFR 25A	ICFS 25	24.1	53	027L4026
ICF 25	6	3RB	1¼	32	Socket weld, ANSI (B 16.11)	ICFS 25	ICFF 25E	ICFE 25	ICFC 25	ICFR 25B	ICFS 25	24.1	53	027L4031
ICF 25	6	3RB	1½	40	Socket weld, ANSI (B 16.11)	ICFS 25	ICFF 25E	ICFE 25	ICFC 25	ICFR 25B	ICFS 25	24.2	53.2	027L4035

**Table 74: Application 10: Liquid feed (no hot gas defrost)**

Type	# of modules	Appl. #	Connection size		Connection type	Module location				Weight		Code number
			[in.]	[mm]		M1	M2	M3	M4	kg	lbs	
ICF 15	4	10HRB	¾	20	Butt-weld ANSI (B 36.10)	ICFS 15 <sup>(1)</sup>	ICFF 15 <sup>(1)</sup>	ICFE 20H	ICFR 20B	7	15.4	027L4585
ICF 20	4	10RA	¾	20	Butt-weld ANSI (B 36.10)	ICFS 20	ICFF 20	ICFE 20	ICFR 20A	6.6	14.5	027L3077
ICF 25	4	10RA	1¼	32	Butt-weld ANSI (B 36.10)	ICFS 25	ICFF 25	ICFE 25	ICFR 25A	16.1	35.4	027L4081
ICF 15	4	10RA	½	15	Butt-weld DIN-EN 10220	ICFS 15 <sup>(1)</sup>	ICFF 15 <sup>(1)</sup>	ICFE 20	ICFR 20A	6.3	13.8	027L4548
ICF 15	4	10RB	½	15	Butt-weld DIN-EN 10220	ICFS 15 <sup>(1)</sup>	ICFF 15 <sup>(1)</sup>	ICFE 20	ICFR 20B	6.3	13.8	027L4544
ICF 15	4	10HRA	½	15	Butt-weld DIN-EN 10220	ICFS 15 <sup>(1)</sup>	ICFF 15 <sup>(1)</sup>	ICFE 20H	ICFR 20A	7	15.4	027L4552
ICF 15	4	10HRB	½	15	Butt-weld DIN-EN 10220	ICFS 15 <sup>(1)</sup>	ICFF 15 <sup>(1)</sup>	ICFE 20H	ICFR 20B	7	15.4	027L4549
ICF 15	4	10RA	¾	20	Butt-weld DIN-EN 10220	ICFS 15 <sup>(1)</sup>	ICFF 15 <sup>(1)</sup>	ICFE 20	ICFR 20A	6.3	13.8	027L4545
ICF 15	4	10RB	¾	20	Butt-weld DIN-EN 10220	ICFS 15 <sup>(1)</sup>	ICFF 15 <sup>(1)</sup>	ICFE 20	ICFR 20B	6.3	13.8	027L4540
ICF 15	4	10HRB	¾	20	Butt-weld DIN-EN 10220	ICFS 15 <sup>(1)</sup>	ICFF 15 <sup>(1)</sup>	ICFE 20H	ICFR 20B	7	15.4	027L4524
ICF 20	4	10RA	¾	20	Butt-weld DIN-EN 10220	ICFS 20	ICFF 20	ICFE 20	ICFR 20A	6.7	14.7	027L3073
ICF 20	4	10HRB	¾	20	Butt-weld DIN-EN 10220	ICFS 20	ICFF 20	ICFE 20H	ICFR 20B	7.9	17.4	027L3383
ICF 20	4	10RA	1	25	Butt-weld DIN-EN 10220	ICFS 20	ICFF 20	ICFE 20	ICFR 20A	7.2	15.8	027L3075
ICF 20	4	10RB	1	25	Butt-weld DIN-EN 10220	ICFS 20	ICFF 20	ICFE 20	ICFR 20B	7.2	15.8	027L3431
ICF 20	4	10HRB	1	25	Butt-weld DIN-EN 10220	ICFS 20	ICFF 20	ICFE 20H	ICFR 20B	7.9	17.4	027L3400

## Valve station, type ICF 15, ICF 20, ICF 25, ICF 50 and ICF 65

Type	# of modules	Appl. #	Connection size		Connection type	Module location				Weight		Code number
			[in.]	[mm]		M1	M2	M3	M4	kg	lbs	
ICF 25	4	10RA	1	25	Butt-weld DIN-EN 10220	ICFS 25	ICFF 25	ICFE 25	ICFR 25A	15.9	35	027L4076
ICF 25	4	10RB	1	25	Butt-weld DIN-EN 10220	ICFS 25	ICFF 25	ICFE 25	ICFR 25B	15.9	35	027L4169
ICF 25	4	10RB	1	25	Butt-weld DIN-EN 10220	ICFS 25	ICFF 25E	ICFE 25	ICFR 25B	16.2	35.6	027L4187
ICF 20	4	10RA	1 ¼	32	Butt-weld DIN-EN 10220	ICFS 20	ICFF 20	ICFE 20	ICFR 20A	6.7	14.7	027L3076
ICF 20	4	10HRB	1 ¼	32	Butt-weld DIN-EN 10220	ICFS 20	ICFF 20	ICFE 20H	ICFR 20B	7.9	17.4	027L3401
ICF 25	4	10RA	1 ¼	32	Butt-weld DIN-EN 10220	ICFS 25	ICFF 25	ICFE 25	ICFR 25A	15.8	34.8	027L4080
ICF 25	4	10RB	1 ¼	32	Butt-weld DIN-EN 10220	ICFS 25	ICFF 25	ICFE 25	ICFR 25B	15.4	33.9	027L4085
ICF 25	4	10RB	1½	40	Butt-weld DIN-EN 10220	ICFS 25	ICFF 25	ICFE 25	ICFR 25B	15.8	34.8	027L4090
ICF 15	4	10RA	½	15	Socket weld, ANSI (B 16.11)	ICFS 15 <sup>(1)</sup>	ICFF 15 <sup>(1)</sup>	ICFE 20	ICFR 20A	6.3	13.8	027L4586
ICF 15	4	10HRB	½	15	Socket weld, ANSI (B 16.11)	ICFS 15 <sup>(1)</sup>	ICFF 15 <sup>(1)</sup>	ICFE 20H	ICFR 20B	7	15.4	027L4530
ICF 15	4	10RA	¾	20	Socket weld, ANSI (B 16.11)	ICFS 15 <sup>(1)</sup>	ICFF 15 <sup>(1)</sup>	ICFE 20	ICFR 20A	6.3	13.8	027L4625
ICF 15	4	10HRB	¾	20	Socket weld, ANSI (B 16.11)	ICFS 15 <sup>(1)</sup>	ICFF 15 <sup>(1)</sup>	ICFE 20H	ICFR 20B	7	15.4	027L4615
ICF 20	4	10RA	¾	20	Socket weld, ANSI (B 16.11)	ICFS 20	ICFF 20E	ICFE 20	ICFR 20A	7	15.4	027L3078
ICF 20	4	10HRB	¾	20	Socket weld, ANSI (B 16.11)	ICFS 20	ICFF 20E	ICFE 20H	ICFR 20B	8.4	18.5	027L3404
ICF 20	4	10RA	1	25	Socket weld, ANSI (B 16.11)	ICFS 20	ICFF 20E	ICFE 20	ICFR 20A	6.9	15.2	027L3080
ICF 20	4	10HRB	1	25	Socket weld, ANSI (B 16.11)	ICFS 20	ICFF 20E	ICFE 20H	ICFR 20B	7.8	17.2	027L3402
ICF 25	4	10RA	1	25	Socket weld, ANSI (B 16.11)	ICFS 25	ICFF 25E	ICFE 25	ICFR 25A	15.8	34.8	027L4077
ICF 20	4	10RA	1 ¼	32	Socket weld, ANSI (B 16.11)	ICFS 20	ICFF 20E	ICFE 20	ICFR 20A	7	15.4	027L3081
ICF 20	4	10HRB	1 ¼	32	Socket weld, ANSI (B 16.11)	ICFS 20	ICFF 20E	ICFE 20H	ICFR 20B	8.1	17.8	027L3403
ICF 25	4	10RA	1 ¼	32	Socket weld, ANSI (B 16.11)	ICFS 25	ICFF 25E	ICFE 25	ICFR 25A	12.7	27.9	027L4082
ICF 25	4	10RB	1 ¼	32	Socket weld, ANSI (B 16.11)	ICFS 25	ICFF 25E	ICFE 25	ICFR 25B	16.2	35.6	027L4087
ICF 25	4	10RB	1½	40	Socket weld, ANSI (B 16.11)	ICFS 25	ICFF 25E	ICFE 25	ICFR 25B	16.2	35.6	027L4091

<sup>(1)</sup> Fixed module



## Valve station, type ICF 15, ICF 20, ICF 25, ICF 50 and ICF 65

**Table 75: Application 15: Liquid feed with external connection**

Type	# of modules	Appl. #	Connection size		Connection type	Module location						Weight		Code number
			[in.]	[mm]		M1	M2	M3	M4	M5	M6	kg	lbs	
ICF 20	6	15RA	1	25	Butt-weld DIN-EN 10220	ICFS 20	ICFF 20	ICFE 20	ICFC 20	ICFW 20D	ICFR 20A	9.1	20	027L3157
ICF 20	6	15RB	1	25	Butt-weld DIN-EN 10220	ICFS 20	ICFF 20	ICFE 20	ICFC 20	ICFW 20D	ICFR 20B	9.1	20	027L3434
ICF 25	6	15RA	1	25	Butt-weld DIN-EN 10220	ICFS 25	ICFF 25	ICFE 25	ICFC 25	ICFW 25D	ICFR 25A	21.8	48	027L4121
ICF 25	6	15RB	1 ¼	32	Butt-weld DIN-EN 10220	ICFS 25	ICFF 25	ICFE 25	ICFC 25	ICFW 25D	ICFR 25B	22.7	49.9	027L4126
ICF 25	6	15RB	1½	40	Butt-weld DIN-EN 10220	ICFS 25	ICFF 25	ICFE 25	ICFC 25	ICFW 25D	ICFR 25B	21.9	48.2	027L4130
ICF 25	6	15RA	1	25	Socket weld, ANSI (B 16.11)	ICFS 25	ICFF 25E	ICFE 25	ICFC 25	ICFW 25S	ICFR 25A	23.5	51.7	027L4122
ICF 25	6	15RB	1 ¼	32	Socket weld, ANSI (B 16.11)	ICFS 25	ICFF 25E	ICFE 25	ICFC 25	ICFW 25S	ICFR 25B	23.6	51.9	027L4127
ICF 25	6	15RB	1½	40	Socket weld, ANSI (B 16.11)	ICFS 25	ICFF 25E	ICFE 25	ICFC 25	ICFW 25S	ICFR 25B	23.7	52.1	027L4131

## Solenoid common

**Table 76: Application 4: Solenoid - Liquid & hot gas lines**

Type	# of modules	Appl. #	Connection size		Connection type	Module location						Weight		Code number
			[in.]	[mm]		M1	M2	M3	M4	M5	M6	kg	lbs	
ICF 20	6	4	1	25	Butt-weld DIN-EN 10220	ICFS 20	ICFF 20	ICFE 20	ICFO 20	ICFB 20	ICFS 20	9.2	20.2	027L3028
ICF 20	6	4	1 ¼	32	Butt-weld DIN-EN 10220	ICFS 20	ICFF 20	ICFE 20	ICFO 20	ICFB 20	ICFS 20	9.2	20.2	027L3029
ICF 20	6	4	¾	20	Socket weld, ANSI (B 16.11)	ICFS 20	ICFF 20E	ICFE 20	ICFO 20	ICFB 20	ICFS 20	9.4	20.7	027L3124
ICF 20	6	4	1	25	Socket weld, ANSI (B 16.11)	ICFS 20	ICFF 20E	ICFE 20	ICFO 20	ICFB 20	ICFS 20	9.3	20.5	027L3032
ICF 20	6	4	1 ¼	32	Socket weld, ANSI (B 16.11)	ICFS 20	ICFF 20E	ICFE 20	ICFO 20	ICFB 20	ICFS 20	9.5	20.9	027L3033

**Table 77: Application 8: Solenoid - Liquid & hot gas lines**

Type	# of modules	Appl. #	Connection size		Connection type	Module location				Weight		Code number
			[in.]	[mm]		M1	M2	M3	M4	kg	lbs	
ICF 15	4	8	½	15	Butt-weld ANSI (B 36.10)	ICFS 15 <sup>(1)</sup>	ICFF 15 <sup>(1)</sup>	ICFE 20	ICFO 20	5.7	12.6	027L4533
ICF 15	4	8	¾	20	Butt-weld ANSI (B 36.10)	ICFS 15 <sup>(1)</sup>	ICFF 15 <sup>(1)</sup>	ICFE 20	ICFO 20	5.7	12.6	027L4535
ICF 20	4	8	¾	20	Butt-weld ANSI (B 36.10)	ICFS 20	ICFF 20	ICFE 20	ICFO 20	6.3	13.9	027L3062
ICF 15	4	8	½	15	Butt-weld DIN-EN 10220	ICFS 15 <sup>(1)</sup>	ICFF 15 <sup>(1)</sup>	ICFE 20	ICFO 20	5.7	12.6	027L4532
ICF 15	4	8	½	15	Butt-weld DIN-EN 10220	ICFS 15 <sup>(1)</sup>	ICFF 15 <sup>(1)</sup>	ICFE 20	ICFN 20	6.8	15	027L4579
ICF 15	4	8	¾	20	Butt-weld DIN-EN 10220	ICFS 15 <sup>(1)</sup>	ICFF 15 <sup>(1)</sup>	ICFE 20	ICFO 20	5.7	12.6	027L4520
ICF 15	4	8	¾r	20	Butt-weld DIN-EN 10220	ICFS 15 <sup>(1)</sup>	ICFF 15 <sup>(1)</sup>	ICFE 20	ICFN 20	6.8	15	027L4574
ICF 20	4	8	1	25	Butt-weld DIN-EN 10220	ICFS 20	ICFF 20	ICFE 20	ICFO 20	7.2	15.8	027L3060

## Valve station, type ICF 15, ICF 20, ICF 25, ICF 50 and ICF 65

Type	# of modules	Appl. #	Connection size		Connection type	Module location				Weight		Code number
			[in.]	[mm]		M1	M2	M3	M4	kg	lbs	
ICF 25	4	8	1	25	Butt-weld DIN-EN 10220	ICFS 25	ICFF 25	ICFE 25	ICFB 25	12.4	27.3	027L4054
ICF 20	4	8	1¼	32	Butt-weld DIN-EN 10220	ICFS 20	ICFF 20	ICFE 20	ICFO 20	6.3	13.9	027L3061
ICF 25	4	8	1¼	32	Butt-weld DIN-EN 10220	ICFS 25	ICFF 25	ICFE 25	ICFB 25	14.5	31.9	027L4133
ICF 25	4	8	1½	40	Butt-weld DIN-EN 10220	ICFS 25	ICFF 25	ICFE 25	ICFB 25	14.5	31.9	027L4059
ICF 15	4	8	½	15	Pipe thread (ANSI B 1.20.1)	ICFS 15 <sup>(1)</sup>	ICFF 15 <sup>(1)</sup>	ICFE 20	ICFO 20	5.7	12.6	027L4534
ICF 15	4	8	½	15	Socket weld, ANSI (B 16.11)	ICFS 15 <sup>(1)</sup>	ICFF 15 <sup>(1)</sup>	ICFE 20	ICFO 20	5.7	12.6	027L4526
ICF 15	4	8	¾	20	Socket weld, ANSI (B 16.11)	ICFS 15 <sup>(1)</sup>	ICFF 15 <sup>(1)</sup>	ICFE 20	ICFO 20	5.7	12.6	027L4611
ICF 20	4	8	¾	20	Socket weld, ANSI (B 16.11)	ICFS 20	ICFF 20E	ICFE 20	ICFO 20	6.6	14.5	027L3366
ICF 20	4	8	1	25	Socket weld, ANSI (B 16.11)	ICFS 20	ICFF 20E	ICFE 20	ICFO 20	6.7	14.7	027L3064
ICF 20	4	8	1¼	32	Socket weld, ANSI (B 16.11)	ICFS 20	ICFF 20E	ICFE 20	ICFO 20	6.7	14.7	027L3065
ICF 15	4	8	7/8	22	Solder ANSI B 16.22	ICFS 15 <sup>(1)</sup>	ICFF 15 <sup>(1)</sup>	ICFE 20	ICFO 20	5.7	12.6	027L4536
ICF 15	4	8	7/8	22	Solder DIN-EN1254-1	ICFS 15 <sup>(1)</sup>	ICFF 15 <sup>(1)</sup>	ICFE 20	ICFO 20	5.7	12.6	027L4537

<sup>(1)</sup> Fixed module

**Table 78: Application 121: Solenoid - generic**

Type	# of Modules	Appl.#	Connection size		Connection type	Module location						Weight		Code number
			[in.]	[mm]		M1	M2	M3	M4	M5	M6	kg	lbs	
ICF 20	2	121	½	15	Butt-weld ASME B 36.10M	ICFE 20	ICFO 20					2.2	4.8	027L3801
ICF 20	2	121	½	15	Butt-weld EN 10220	ICFE 20	ICFO 20					2.1	4.7	027L3802
ICF 20	2	121	¾	20	Butt-weld EN 10220	ICFE 20	ICFO 20					2.1	4.6	027L3803
ICF 20	2	121H	¾	20	Butt-weld EN 10220	ICFE 20H	ICFB 20					2.9	6.3	027L3804
ICF 20	2	121	¾	20	Butt-weld ASME B 36.10M	ICFE 20	ICFO 20					2.1	4.7	027L3805
ICF 20	2	121H	¾	20	Butt-weld ASME B 36.10M	ICFE 20H	ICFB 20					2.9	6.4	027L3806
ICF 20	2	121H	1	25	Butt-weld EN 10220	ICFE 20H	ICFB 20					2.9	6.3	027L3807
ICF 20	2	121H	1	25	Butt-weld ASME B 36.10M	ICFE 20H	ICFB 20					2.9	6.4	027L3808
ICF 20	2	121	¾	20	Butt-weld ASM B 16.11	ICFE 20	ICFO 20					2.2	4.8	027L3809
ICF 20	2	121H	¾	20	Butt-weld ASM B 16.11	ICFE 20H	ICFB 20					3.0	6.5	027L3810
ICF 20	2	121	7/8	22	Brazing DIN/EN 1254-5	ICFE 20	ICFO 20					2.1	4.7	027L3811
ICF 20	2	121H	7/8	22	Brazing DIN/EN 1254-5	ICFE 20H	ICFB 20					2.9	6.3	027L3812
ICF 20	2	121	7/8	22	Brazing ASME B16.50	ICFE 20	ICFO 20					2.1	4.7	027L3813
ICF 20	2	121H	7/8	22	Brazing ASME B16.50	ICFE 20H	ICFB 20					2.9	6.3	027L3814

Liquid injection

Table 79: Application 5: Liquid injection (expansion)

Type	# of modules	Appl. #	Connection size		Connection type	Module location						Weight		Code number
			[in.]	[mm]		M1	M2	M3	M4	M5	M6	kg	lbs	
ICF 20	6	5MA	¾	20	Butt-weld ANSI (B 36.10)	ICFS 20	ICFF 20	ICFE 20	ICFO 20	ICM 20-A	ICFS 20	9.6	21.1	027L3037
ICF 20	6	5MB	¾	20	Butt-weld ANSI (B 36.10)	ICFS 20	ICFF 20	ICFE 20	ICFO 20	ICM 20-B	ICFS 20	9.9	21.8	027L3043
ICF 25	6	5MA	1 ¼	32	Butt-weld ANSI (B 36.10)	ICFS 25	ICFF 25	ICFE 25	ICFB 25	ICM 25-A	ICFS 25	23	50.6	027L4043
ICF 20	6	5MA33	¾	20	Butt-weld DIN-EN 10220	ICFS 20	ICFF 20	ICFE 20	ICFO 20	ICM 20-A33	ICFS 20	10.1	22.2	027L3367
ICF 20	6	5MA33	¾	20	Butt-weld DIN-EN 10220	ICFS 20	ICFF 20-74	ICFE 20	ICFO 20	ICM 20-A33	ICFS 20	9.8	21.6	027L3151
ICF 20	6	5MA	¾	20	Butt-weld DIN-EN 10220	ICFS 20	ICFF 20	ICFE 20	ICFO 20	ICM 20-A	ICFS 20	9.8	21.6	027L3034
ICF 20	6	5MA	¾	20	Butt-weld DIN-EN 10220	ICFS 20	ICFF 20-74	ICFE 20	ICFO 20	ICM 20-A	ICFS 20	9.8	21.6	027L3147
ICF 20	6	5MB	¾	20	Butt-weld DIN-EN 10220	ICFS 20	ICFF 20	ICFE 20	ICFO 20	ICM 20-B	ICFS 20	9.8	21.6	027L3145
ICF 20	6	5MB66	¾	20	Butt-weld DIN-EN 10220	ICFS 20	ICFF 20	ICFE 20	ICFO 20	ICM 20-B66	ICFS 20	9.6	21.1	027L3161
ICF 20	6	5MC	¾	20	Butt-weld DIN-EN 10220	ICFS 20	ICFF 20	ICFE 20	ICFO 20	ICM 20-C	ICFS 20	9.9	21.8	027L3432
ICF 20	6	5MA33	1	25	Butt-weld DIN-EN 10220	ICFS 20	ICFF 20	ICFE 20	ICFO 20	ICM 20-A33	ICFS 20	10.1	22.2	027L3388
ICF 20	6	5MA33	1	25	Butt-weld DIN-EN 10220	ICFS 20	ICFF 20-74	ICFE 20	ICFO 20	ICM 20-A33	ICFS 20	9.6	21.1	027L3153
ICF 20	6	5MA	1	25	Butt-weld DIN-EN 10220	ICFS 20	ICFF 20	ICFE 20	ICFO 20	ICM 20-A	ICFS 20	9.8	21.6	027L3036
ICF 20	6	5HMA	1	25	Butt-weld DIN-EN 10220	ICFS 20	ICFF 20	ICFE 20H	ICFB 20	ICM 20-A	ICFS 20	10.4	22.9	027L3322
ICF 20	6	5MA	1	25	Butt-weld DIN-EN 10220	ICFS 20	ICFF 20-74	ICFE 20	ICFO 20	ICM 20-A	ICFS 20	9.8	21.6	027L3148
ICF 20	6	5MB	1	25	Butt-weld DIN-EN 10220	ICFS 20	ICFF 20	ICFE 20	ICFO 20	ICM 20-B	ICFS 20	9.6	21.1	027L3042
ICF 20	6	5MB	1	25	Butt-weld DIN-EN 10220	ICFS 20	ICFF 20-74	ICFE 20	ICFO 20	ICM 20-B	ICFS 20	9.8	21.6	027L3149
ICF 20	6	5HMB	1	25	Butt-weld DIN-EN 10220	ICFS 20	ICFF 20	ICFE 20H	ICFB 20	ICM 20-B	ICFS 20	11.4	25.1	027L3325
ICF 20	6	5MB66	1	25	Butt-weld DIN-EN 10220	ICFS 20	ICFF 20	ICFE 20	ICFO 20	ICM 20-B66	ICFS 20	10.5	23.1	027L3389
ICF 20	6	5MC	1	25	Butt-weld DIN-EN 10220	ICFS 20	ICFF 20	ICFE 20	ICFO 20	ICM 20-C	ICFS 20	9.9	21.8	027L3047
ICF 20	6	5HMC	1	25	Butt-weld DIN-EN 10220	ICFS 20	ICFF 20	ICFE 20H	ICFB 20	ICM 20-C	ICFS 20	11.4	25.1	027L3328
ICF 25	6	5MA	1	25	Butt-weld DIN-EN 10220	ICFS 25	ICFF 25	ICFE 25	ICFB 25	ICM 25-A	ICFS 25	22.8	50.2	027L4038

## Valve station, type ICF 15, ICF 20, ICF 25, ICF 50 and ICF 65

Type	# of modules	Appl. #	Connection size		Connection type	Module location						Weight		Code number
			[in.]	[mm]		M1	M2	M3	M4	M5	M6	kg	lbs	
ICF 25	6	5MA33	1 ¼	32	Butt-weld DIN-EN 10220	ICFS 25	ICFF 25	ICFE 25	ICFB 25	ICM 25-A33	ICFS 25	23	50.6	027L4171
ICF 20	6	5MB66	1 ¼	32	Butt-weld DIN-EN 10220	ICFS 20	ICFF 20	ICFE 20	ICFO 20	ICM 20-B66	ICFS 20	9.6	21.1	027L3374
ICF 20	6	5MC	1 ¼	32	Butt-weld DIN-EN 10220	ICFS 20	ICFF 20	ICFE 20	ICFO 20	ICM 20-C	ICFS 20	9.8	21.6	027L3048
ICF 20	6	5HMB	1 ¼	32	Butt-weld DIN-EN 10220	ICFS 20	ICFF 20	ICFE 20-H	ICFB 20	ICM 20-B	ICFS 20	10.3	22.7	027L3390
ICF 20	6	5HMC	1 ¼	32	Butt-weld DIN-EN 10220	ICFS 20	ICFF 20	ICFE 20H	ICFB 20	ICM 20-C	ICFS 20	10.3	22.7	027L3329
ICF 25	6	5MA	1 ¼	32	Butt-weld DIN-EN 10220	ICFS 25	ICFF 25	ICFE 25	ICFB 25	ICM 25-A	ICFS 25	23	50.6	027L4042
ICF 25	6	5MB	1 ¼	32	Butt-weld DIN-EN 10220	ICFS 25	ICFF 25	ICFE 25	ICFB 25	ICM 25-B	ICFS 25	22	48.5	027L4047
ICF 25	6	5MA	1½	40	Butt-weld DIN-EN 10220	ICFS 25	ICFF 25E	ICFE 25	ICFB 25	ICM 25-A	ICFS 25	21.9	48.2	027L4148
ICF 25	6	5MA	1½	40	Butt-weld DIN-EN 10220	ICFS 25	ICFF 25	ICFE 25	ICFB 25	ICM 25-A	ICFS 25	22.2	48.9	027L4174
ICF 25	6	5MA33	1½	40	Butt-weld DIN-EN 10220	ICFS 25	ICFF 25	ICFE 25	ICFB 25	ICM 25-A33	ICFS 25	22.2	48.9	027L4170
ICF 25	6	5MB	1½	40	Butt-weld DIN-EN 10220	ICFS 25	ICFF 25	ICFE 25	ICFB 25	ICM 25-B	ICFS 25	22.2	48.9	027L4052
ICF 20	6	5MA33	¾	20	Socket weld, ANSI (B 16.11)	ICFS 20	ICFF 20E	ICFE 20	ICFO 20	ICM 20-A33	ICFS 20	10.1	22.2	027L3154
ICF 20	6	5MA	¾	20	Socket weld, ANSI (B 16.11)	ICFS 20	ICFF 20E	ICFE 20	ICFO 20	ICM 20-A	ICFS 20	10	22	027L3038
ICF 20	6	5MB66	¾	20	Socket weld, ANSI (B 16.11)	ICFS 20	ICFF 20E	ICFE 20	ICFO 20	ICM 20-B66	ICFS 20	10.5	23.1	027L3159
ICF 20	6	5MB	¾	20	Socket weld, ANSI (B 16.11)	ICFS 20	ICFF 20E	ICFE 20	ICFO 20	ICM 20-B	ICFS 20	9.8	21.6	027L3127
ICF 20	6	5MA33	1	25	Socket weld, ANSI (B 16.11)	ICFS 20	ICFF 20-E	ICFE 20	ICFO 20	ICM 20-A33	ICFS 20	10.1	22.2	027L3391
ICF 20	6	5MA	1	25	Socket weld, ANSI (B 16.11)	ICFS 20	ICFF 20E	ICFE 20	ICFO 20	ICM 20-A	ICFS 20	10.1	22.2	027L3040
ICF 20	6	5HMA	1	25	Socket weld, ANSI (B 16.11)	ICFS 20	ICFF 20E	ICFE 20H	ICFB 20	ICM 20-A	ICFS 20	11.4	25.1	027L3323
ICF 20	6	5MB66	1	25	Socket weld, ANSI (B 16.11)	ICFS 20	ICFF 20E	ICFE 20	ICFO 20	ICM 20-B66	ICFS 20	10.5	23.1	027L3160
ICF 20	6	5MB	1	25	Socket weld, ANSI (B 16.11)	ICFS 20	ICFF 20E	ICFE 20	ICFO 20	ICM 20-B	ICFS 20	10	22	027L3045
ICF 20	6	5HMB	1	25	Socket weld, ANSI (B 16.11)	ICFS 20	ICFF 20E	ICFE 20H	ICFB 20	ICM 20-B	ICFS 20	11	24.2	027L3326
ICF 20	6	5MC	1	25	Socket weld, ANSI (B 16.11)	ICFS 20	ICFF 20E	ICFE 20	ICFO 20	ICM 20-C	ICFS 20	10	22	027L3051
ICF 20	6	5HMC	1	25	Socket weld, ANSI (B 16.11)	ICFS 20	ICFF 20E	ICFE 20H	ICFB 20	ICM 20-C	ICFS 20	10	22	027L3330

## Valve station, type ICF 15, ICF 20, ICF 25, ICF 50 and ICF 65

Type	# of modules	Appl. #	Connection size		Connection type	Module location						Weight		Code number
			[in.]	[mm]		M1	M2	M3	M4	M5	M6	kg	lbs	
ICF 25	6	5MA	1	25	Socket weld, ANSI (B 16.11)	ICFS 25	ICFF 25E	ICFE 25	ICFB 25	ICM 25-A	ICFS 25	23.1	50.8	027L4039
ICF 25	6	5MA33	1 ¼	32	Socket weld, ANSI (B 16.11)	ICFS 25	ICFF 25-E	ICFE 25	ICFB 25	ICM 25-A33	ICFS 25	22	48.5	027L4173
ICF 25	6	5MA	1 ¼	32	Socket weld, ANSI (B 16.11)	ICFS 25	ICFF 25E	ICFE 25	ICFB 25	ICM 25-A	ICFS 25	23.2	51	027L4044
ICF 20	6	5MB66	1 ¼	32	Socket weld, ANSI (B 16.11)	ICFS 20	ICFF 20-E	ICFE 20	ICFO 20	ICM 20-B66	ICFS 20	10.5	23.1	027L3392
ICF 25	6	5MB	1 ¼	32	Socket weld, ANSI (B 16.11)	ICFS 25	ICFF 25-E	ICFE 25	ICFB 25	ICM 25-B	ICFS 25	23.2	51.1	027L4049
ICF 20	6	5MC	1 ¼	32	Socket weld, ANSI (B 16.11)	ICFS 20	ICFF 20E	ICFE 20	ICFO 20	ICM 20-C	ICFS 20	10.1	22.2	027L3052
ICF 20	6	5HMB	1 ¼	32	Socket weld, ANSI (B 16.11)	ICFS 20	ICFF 20-E	ICFE 20-H	ICFB 20	ICM 20-B	ICFS 20	11	24.2	027L3393
ICF 25	6	5MA	1 ½	40	Socket weld, ANSI (B 16.11)	ICFS 20	ICFF 20E	ICFE 20H	ICFB 20	ICM 20-C	ICFS 20	11	24.2	027L3331
ICF 25	6	5MA33	1 ½	40	Socket weld, ANSI (B 16.11)	ICFS 25	ICFF 25-E	ICFE 25	ICFB 25	ICM 25-A33	ICFS 25	22	48.5	027L4172
ICF 25	6	5MA	1 ½	40	Socket weld, ANSI (B 16.11)	ICFS 25	ICFF 25-E	ICFE 25	ICFB 25	ICM 25-A33	ICFS 25	23.1	50.8	027L4132
ICF 25	6	5MB	1 ½	40	Socket weld, ANSI (B 16.11)	ICFS 25	ICFF 25-E	ICFE 25	ICFB 25	ICM 25-B	ICFS 25	23.2	51.1	027L4053

**Table 80: Application 12: Liquid injection (expansion) PWM**

Type	# of modules	Appl. #	Connection size		Connection type	Module location				Weight		Code number
			[in.]	[mm]		M1	M2	M3	M4	kg	lbs	
ICF 15	4	12	¾	20	Butt-weld ANSI (B 36.10)	ICFS 15 <sup>(1)</sup>	ICFF 15 <sup>(1)</sup>	ICFA 20	ICFS 20	6.2	13.7	027L4556
ICF 15	4	12	½	15	Butt-weld DIN-EN 10220	ICFS 15 <sup>(1)</sup>	ICFF 15 <sup>(1)</sup>	ICFA 20	ICFS 20	6.2	13.7	027L4573
ICF 15	4	12	¾	20	Butt-weld DIN-EN 10220	ICFS 15 <sup>(1)</sup>	ICFF 15 <sup>(1)</sup>	ICFA 20	ICFS 20	6.2	13.7	027L4522
ICF 20	4	12	¾	20	Butt-weld DIN-EN 10220	ICFS 20	ICFF 20	ICFA 20	ICFS 20	6.8	15	027L3089
ICF 15	4	12	½	15	Socket weld, ANSI (B 16.11)	ICFS 15 <sup>(1)</sup>	ICFF 15 <sup>(1)</sup>	ICFA 20	ICFS 20	6.2	13.7	027L4528
ICF 15	4	12	¾	20	Socket weld, ANSI (B 16.11)	ICFS 15 <sup>(1)</sup>	ICFF 15 <sup>(1)</sup>	ICFA 20	ICFS 20	6.2	13.7	027L4613
ICF 20	4	12	¾	20	Socket weld, ANSI (B 16.11)	ICFS 20	ICFF 20E	ICFA 20	ICFS 20	6.8	15	027L3091

<sup>(1)</sup> Fixed module

## Valve station, type ICF 15, ICF 20, ICF 25, ICF 50 and ICF 65

**Table 81: Application 14: Liquid injection (expansion)**

Type	# of modules	Appl. #	Connection size		Connection type	Module location				Weight		Code number
			[in.]	[mm]		M1	M2	M3	M4	kg	lbs	
ICF 15	4	14MA	½	15	Butt-weld DIN-EN 10220	ICFS 15 <sup>(1)</sup>	ICFF 15 <sup>(1)</sup>	ICM 20-A	ICFS 20	6.8	15	027L4551
ICF 15	4	14MB	½	15	Butt-weld DIN-EN 10220	ICFS 15 <sup>(1)</sup>	ICFF 15 <sup>(1)</sup>	ICM 20-B	ICFS 20	6.8	15	027L4559
ICF 20	4	14MA33	¾	20	Butt-weld DIN-EN 10220	ICFS 20	ICFF 20	ICM 20-A33	ICFS 20	7.3	16.1	027L3394
ICF 15	4	14MA	¾	20	Butt-weld DIN-EN 10220	ICFS 15 <sup>(1)</sup>	ICFF 15 <sup>(1)</sup>	ICM 20-A	ICFS 20	6.8	15	027L4525
ICF 20	4	14MA	¾	20	Butt-weld DIN-EN 10220	ICFS 20	ICFF 20	ICM 20-A	ICFS 20	7.3	16.1	027L3095
ICF 15	4	14MB66	¾	20	Butt-weld DIN-EN 10220	ICFS 15 <sup>(1)</sup>	ICFF 15 <sup>(1)</sup>	ICM 20-B66	ICFS 20	6.8	15	027L4553
ICF 20	4	14MB66	¾	20	Butt-weld DIN-EN 10220	ICFS 20	ICFF 20	ICM 20-B66	ICFS 20	7.2	15.8	027L4155
ICF 15	4	14MB	¾	20	Butt-weld DIN-EN 10220	ICFS 15 <sup>(1)</sup>	ICFF 15 <sup>(1)</sup>	ICM 20-B	ICFS 20	6.8	15	027L4560
ICF 20	4	14 MA33	1	25	Butt-weld DIN-EN 10220	ICFS 20	ICFF 20	ICM 20-A33	ICFS 20	6.6	14.5	027L3365
ICF 20	4	14MA	1	25	Butt-weld DIN-EN 10220	ICFS 20	ICFF 20	ICM 20-A	ICFS 20	7.3	16.1	027L3097
ICF 20	4	14MB66	1	25	Butt-weld DIN-EN 10220	ICFS 20	ICFF 20	ICM 20-B66	ICFS 20	7.2	15.8	027L3356
ICF 20	4	14MB	1	25	Butt-weld DIN-EN 10220	ICFS 20	ICFF 20	ICM 20-B	ICFS 20	7.2	15.8	027L3103
ICF 20	4	14MC	1	25	Butt-weld DIN-EN 10220	ICFS 20	ICFF 20	ICM 20-C	ICFS 20	7.2	15.8	027L3108
ICF 25	4	14MA	1	25	Butt-weld DIN-EN 10220	ICFS 25	ICFF 25	ICM 25-A	ICFS 25	15.5	34.1	027L4103
ICF 20	4	14MC	1 ¼	32	Butt-weld DIN-EN 10220	ICFS 20	ICFF 20	ICM 20-C	ICFS 20	7.3	16.1	027L3109
ICF 25	4	14MB	1 ¼	32	Butt-weld DIN-EN 10220	ICFS 25	ICFF 25	ICM 25-B	ICFS 25	14.4	31.7	027L4112
ICF 25	4	14MA	1 ¼	32	Butt-weld DIN-EN 10220	ICFS 25	ICFF 25	ICM 25-A	ICFS 25	15.4	33.9	027L4107
ICF 25	4	14MA	1 ½	40	Butt-weld DIN-EN 10220	ICFS 25	ICFF 25	ICM 25-A	ICFS 25	15.3	33.7	027L4182
ICF 25	4	14MB	1 ½	40	Butt-weld DIN-EN 10220	ICFS 25	ICFF 25	ICM 25-B	ICFS 25	15.3	33.7	027L4117
ICF 15	4	14MA	½	15	Socket weld, ANSI (B 16.11)	ICFS 15 <sup>(1)</sup>	ICFF 15 <sup>(1)</sup>	ICM 20-A	ICFS 20	6.8	15	027L4531
ICF 15	4	14MB	½	15	Socket weld, ANSI (B 16.11)	ICFS 15 <sup>(1)</sup>	ICFF 15 <sup>(1)</sup>	ICM 20-B	ICFS 20	6.8	15	027L4583
ICF 15	4	14MB	¾	20	Socket weld, ANSI (B 16.11)	ICFS 15 <sup>(1)</sup>	ICFF 15 <sup>(1)</sup>	ICM 20-B	ICFS 20	6.8	15	027L4623
ICF 15	4	14MA	¾	20	Socket weld, ANSI (B 16.11)	ICFS 15 <sup>(1)</sup>	ICFF 15 <sup>(1)</sup>	ICM 20-A	ICFS 20	6.8	15	027L4616

## Valve station, type ICF 15, ICF 20, ICF 25, ICF 50 and ICF 65

Type	# of modules	Appl. #	Connection size		Connection type	Module location				Weight		Code number
			[in.]	[mm]		M1	M2	M3	M4	kg	lbs	
ICF 20	4	14MA	¾	20	Socket weld, ANSI (B 16.11)	ICFS 20	ICFF 20E	ICM 20-A	ICFS 20	7.5	16.5	027L3099
ICF 20	4	14MA	1	25	Socket weld, ANSI (B 16.11)	ICFS 20	ICFF 20E	ICM 20-A	ICFS 20	6.7	14.7	027L3101
ICF 20	4	14MB	1	25	Socket weld, ANSI (B 16.11)	ICFS 20	ICFF 20E	ICM 20-B	ICFS 20	6.7	14.7	027L3106
ICF 25	4	14MB	1	25	Socket weld, ANSI (B 16.11)	ICFS 25	ICFF 25	ICM 25-B	ICFS 25	14.4	31.7	027L4188
ICF 25	4	14MB	1 ¼	32	Socket weld, ANSI (B 16.11)	ICFS 25	ICFF 25E	ICM 25-B	ICFS 25	17.3	38.1	027L4114
ICF 25	4	14MB	1 ½	40	Socket weld, ANSI (B 16.11)	ICFS 25	ICFF 25E	ICM 25-B	ICFS 25	16.6	36.6	027L4118
ICF 20	4	14MC	1	25	Socket weld, ANSI (B 16.11)	ICFS 20	ICFF 20E	ICM 20-C	ICFS 20	6.7	14.7	027L3112
ICF 25	4	14MA	1	25	Socket weld, ANSI (B 16.11)	ICFS 25	ICFF 25E	ICM 25-A	ICFS 25	15.8	34.8	027L4104
ICF 20	4	14MC	1 ¼	32	Socket weld, ANSI (B 16.11)	ICFS 20	ICFF 20E	ICM 20-C	ICFS 20	7.4	16.3	027L3113
ICF 25	4	14MA	1 ¼	32	Socket weld, ANSI (B 16.11)	ICFS 25	ICFF 25E	ICM 25-A	ICFS 25	15.6	34.3	027L4109
ICF 25	4	14MA	1 ½	40	Socket weld, ANSI (B 16.11)	ICFS 25	ICFF 25E	ICM 25-A	ICFS 25	15.8	34.8	027L4140

<sup>(1)</sup> Fixed module

## Hot gas defrost

**Table 82: Application 9: Hot gas defrost**

Type	# of modules	Appl. #	Connection size		Connection type	Module location				Weight		Code number
			[in.]	[mm]		M1	M2	M3	M4	kg	lbs	
ICF 20	4	9	¾	20	Butt-weld ANSI (B 36.10)	ICFS 20	ICFF 20	ICFE 20	ICFS 20	7.2	15.8	027L3069
ICF 15	4	9H	¾	20	Butt-weld ANSI (B 36.10)	ICFS 15 <sup>(1)</sup>	ICFF 15 <sup>(1)</sup>	ICFE 20H	ICFS 20	7.2	15.4	027L4554
ICF 15	4	9	½	15	Butt-weld DIN-EN 10220	ICFS 15 <sup>(1)</sup>	ICFF 15 <sup>(1)</sup>	ICFE 20	ICFS 20	6.3	13.9	027L4543
ICF 15	4	9H	½	15	Butt-weld DIN-EN 10220	ICFS 15 <sup>(1)</sup>	ICFF 15 <sup>(1)</sup>	ICFE 20H	ICFS 20	7.2	15.4	027L4541
ICF 15	4	9	¾	20	Butt-weld DIN-EN 10220	ICFS 15 <sup>(1)</sup>	ICFF 15 <sup>(1)</sup>	ICFE 20	ICFS 20	6.3	13.9	027L4571
ICF 20	4	9	¾	20	Butt-weld DIN-EN 10220	ICFS 20	ICFF 20	ICFE 20	ICFS 20	6.7	14.7	027L3120
ICF 15	4	9H	¾	20	Butt-weld DIN-EN 10220	ICFS 15 <sup>(1)</sup>	ICFF 15 <sup>(1)</sup>	ICFE 20H	ICFS 20	7.2	15.4	027L4521
ICF 20	4	9	1	25	Butt-weld DIN-EN 10220	ICFS 20	ICFF 20	ICFE 20	ICFS 20	7.2	15.8	027L3067

## Valve station, type ICF 15, ICF 20, ICF 25, ICF 50 and ICF 65

Type	# of modules	Appl. #	Connection size		Connection type	Module location				Weight		Code number
			[in.]	[mm]		M1	M2	M3	M4	kg	lbs	
ICF 20	4	9H	1	25	Butt-weld DIN-EN 10220	ICFS 20	ICFF 20	ICFE 20H	ICFS 20	8.2	18	027L3333
ICF 25	4	9	1	25	Butt-weld DIN-EN 10220	ICFS 25	ICFF 25	ICFE 25	ICFS 25	15.8	34.8	027L4063
ICF 20	4	9	1 ¼	32	Butt-weld DIN-EN 10220	ICFS 20	ICFF 20	ICFE 20	ICFS 20	6.8	15	027L3068
ICF 20	4	9H	1 ¼	32	Butt-weld DIN-EN 10220	ICFS 20	ICFF 20	ICFE 20H	ICFS 20	7.6	16.7	027L3334
ICF 25	4	9	1 ¼	32	Butt-weld DIN-EN 10220	ICFS 25	ICFF 25	ICFE 25	ICFS 25	15.7	34.5	027L4067
ICF 25	4	9	1 ½	40	Butt-weld DIN-EN 10220	ICFS 25	ICFF 25	ICFE 25	ICFS 25	15.7	34.5	027L4072
ICF 15	4	9	½	15	Socket weld, ANSI (B 16.11)	ICFS 15 <sup>(1)</sup>	ICFF 15 <sup>(1)</sup>	ICFE 20	ICFS 20	6.3	13.9	027L4538
ICF 15	4	9H	½	15	Socket weld, ANSI (B 16.11)	ICFS 15 <sup>(1)</sup>	ICFF 15 <sup>(1)</sup>	ICFE 20H	ICFS 20	7.2	15.4	027L4527
ICF 15	4	9	¾	20	Socket weld, ANSI (B 16.11)	ICFS 15 <sup>(1)</sup>	ICFF 15 <sup>(1)</sup>	ICFE 20	ICFS 20	6.3	13.9	027L4618
ICF 15	4	9H	¾	20	Socket weld, ANSI (B 16.11)	ICFS 15 <sup>(1)</sup>	ICFF 15 <sup>(1)</sup>	ICFE 20H	ICFS 20	7.2	15.4	027L4612
ICF 20	4	9H	¾	20	Socket weld, ANSI (B 16.11)	ICFS 20	ICFF 20E	ICFE 20H	ICFS 20	8	17.6	027L3351
ICF 20	4	9	1	25	Socket weld, ANSI (B 16.11)	ICFS 20	ICFF 20E	ICFE 20	ICFS 20	7	15.4	027L3071
ICF 20	4	9H	1	25	Socket weld, ANSI (B 16.11)	ICFS 20	ICFF 20E	ICFE 20H	ICFS 20	8.1	17.8	027L3336
ICF 25	4	9	1	25	Socket weld, ANSI (B 16.11)	ICFS 25	ICFF 25E	ICFE 25	ICFS 25	16	35.2	027L4064
ICF 20	4	9	1 ¼	32	Socket weld, ANSI (B 16.11)	ICFS 20	ICFF 20E	ICFE 20	ICFS 20	7.4	16.3	027L3072
ICF 20	4	9H	1 ¼	32	Socket weld, ANSI (B 16.11)	ICFS 20	ICFF 20E	ICFE 20H	ICFS 20	7.9	17.4	027L3337
ICF 25	4	9	1 ¼	32	Socket weld, ANSI (B 16.11)	ICFS 25	ICFF 25E	ICFE 25	ICFS 25	16	35.2	027L4069
ICF 25	4	9	1 ½	40	Socket weld, ANSI (B 16.11)	ICFS 25	ICFF 25E	ICFE 25	ICFS 25	16.1	35.4	027L4073

<sup>(1)</sup> Fixed module



### Hot gas defrost (ICF 50 only)

**Table 83: Application 47: Hot gas defrost - On/Off 2-step solenoid (ICF 50 only)**

Type	# of modules	Appl. #	Connection size		Connection type	Module location				Weight		Code number	
			[in.]	[mm]		M1	M2	M3	M4	kg	lbs		
ICF 50	4	47	1 ½	40	Socket weld, ANSI (B 16.11)	S	SVA-S 50	FIA 50	ICSH 50-32	SVA-S 50	25.8	56.8	027L5070
ICF 50	4	47	1 ½	40	Socket weld, ANSI (B 16.11)	S	SVA-S 50	FIA 50	ICSH 50-40	SVA-S 50	25.8	56.8	027L5071
ICF 50	4	47	2	50	Socket weld, ANSI (B 16.11)	S	SVA-S 50	FIA 50	ICSH 50-40	SVA-S 50	25.8	56.8	027L5072
ICF 50	4	47	2	50	Socket weld, ANSI (B 16.11)	S	SVA-S 50	FIA 50	ICSH 50	SVA-S 50	25.8	56.8	027L5073

**Table 84: Application 48: Hot gas defrost - On/Off 2-step solenoid + manual Regulating (ICF 50 only)**

Type	# of modules	Appl. #	Connection size		Connection type	Module location				Weight		Code number	
			[in.]	[mm]		M1	M2	M3	M4	kg	lbs		
ICF 50	4	48	1 ½	40	Socket weld, ANSI (B 16.11)	S	SVA-S 50	FIA 50	ICSH 50-32	REG-SB 50	25.8	56.8	027L5074

### Solenoid multiple evaporators

**Table 85: Application 11: Solenoid - Multiple evaporators**

Type	# of modules	Appl. #	Connection size		Connection type	Module location				Weight		Code number
			[in.]	[mm]		M1	M2	M3	M4	kg	lbs	
ICF 20	4	11	¾	20	Butt-weld ANSI (B 36.10)	ICFS 20	ICFF 20	ICFE 20	ICFC 20	6.5	14.3	027L3085
ICF 15	4	11	½	15	Butt-weld DIN-EN 10220	ICFS 15 <sup>(1)</sup>	ICFF 15 <sup>(1)</sup>	ICFE 20	ICFC 20	6.5	14.3	027L4539
ICF 15	4	11	¾	20	Butt-weld DIN-EN 10220	ICFS 15 <sup>(1)</sup>	ICFF 15 <sup>(1)</sup>	ICFE 20	ICFC 20	6.5	14.3	027L4547
ICF 15	4	11H	¾	20	Butt-weld DIN-EN 10220	ICFS 15 <sup>(1)</sup>	ICFF 15 <sup>(1)</sup>	ICFE 20-H	ICFC 20	7.2	15.8	027L4546
ICF 20	4	11	¾	20	Butt-weld DIN-EN 10220	ICFS 20	ICFF 20	ICFE 20	ICFC 20	6.4	14.1	027L4580
ICF 20	4	11	1	25	Butt-weld DIN-EN 10220	ICFS 20	ICFF 20	ICFE 20	ICFC 20	6.4	14.1	027L3083
ICF 20	4	11H	1	25	Butt-weld DIN-EN 10220	ICFS 20	ICFF 20	ICFE 20H	ICFC 20	8	17.6	027L3345
ICF 20	4	11	1 ¼	32	Butt-weld DIN-EN 10220	ICFS 20	ICFF 20	ICFE 20	ICFC 20	6.5	14.3	027L3084
ICF 20	4	11H	1 ¼	32	Butt-weld DIN-EN 10220	ICFS 20	ICFF 20	ICFE 20H	ICFC 20	7.4	16.3	027L3346
ICF 25	4	11	1 ¼	32	Butt-weld DIN-EN 10220	ICFS 25	ICFF 25	ICFE 25	ICFC 25	14.9	32.8	027L4094
ICF 25	4	11	1 ½	40	Butt-weld DIN-EN 10220	ICFS 25	ICFF 25	ICFE 25	ICFC 25	13.7	30.1	027L4099
ICF 20	4	11	1	25	Socket weld, ANSI (B 16.11)	ICFS 20	ICFF 20E	ICFE 20	ICFC 20	6.9	15.2	027L3087

## Valve station, type ICF 15, ICF 20, ICF 25, ICF 50 and ICF 65

Type	# of modules	Appl. #	Connection size		Connection type	Module location				Weight		Code number
			[in.]	[mm]		M1	M2	M3	M4	kg	lbs	
ICF 20	4	11H	1	25	Socket weld, ANSI (B 16.11)	ICFS 20	ICFF 20E	ICFE 20H	ICFC 20	8	17.6	027L3348
ICF 20	4	11	1 ¼	32	Socket weld, ANSI (B 16.11)	ICFS 20	ICFF 20E	ICFE 20	ICFC 20	6.7	14.7	027L3088
ICF 20	4	11H	1 ¼	32	Socket weld, ANSI (B 16.11)	ICFS 20	ICFF 20E	ICFE 20H	ICFC 20	7.4	16.3	027L3349
ICF 25	4	11	1 ¼	32	Socket weld, ANSI (B 16.11)	ICFS 25	ICFF 25E	ICFE 25	ICFC 25	13	28.6	027L4096
ICF 25	4	11	1 ½	40	Socket weld, ANSI (B 16.11)	ICFS 25	ICFF 25E	ICFE 25	ICFC 25	14.3	31.5	027L4100

<sup>(1)</sup> Fixed module

**Table 86: Application 18: Solenoid - Multiple evaporators**

Type	# of modules	Appl. #	Connection size		Connection type	Module location				Weight		Code number
			[in.]	[mm]		M1	M2	M3	M4	kg	lbs	
ICF 15	4	18H	¾	20	Butt-weld ANSI (B 36.10)	ICFS 15 <sup>(1)</sup>	ICFF 15 <sup>(1)</sup>	ICFE 20-H	ICFN 20	7.2	15.8	027L4572
ICF 15	4	18H	½	15	Butt-weld DIN-EN 10220	ICFS 15 <sup>(1)</sup>	ICFF 15 <sup>(1)</sup>	ICFE 20-H	ICFN 20	7.2	15.8	027L4542
ICF 15	4	18H	¾	20	Butt-weld DIN-EN 10220	ICFS 15 <sup>(1)</sup>	ICFF 15 <sup>(1)</sup>	ICFE 20-H	ICFN 20	7.2	15.8	027L4550
ICF 20	4	18	1	25	Butt-weld DIN-EN 10220	ICFS 20	ICFF 20E	ICFE 20	ICFN 20	7.3	16	027L3438
ICF 25	4	18	1	25	Butt-weld DIN-EN 10220	ICFS 25	ICFF 25	ICFE 25	ICFN 25	15.8	34.8	027L4175
ICF 25	4	18	1 ¼	32	Butt-weld DIN-EN 10220	ICFS 25	ICFF 25	ICFE 25	ICFN 25	16.6	36.5	027L4164
ICF 25	4	18	1 ¼	32	Butt-weld DIN-EN 10220	ICFS 25	ICFF 25E	ICFE 25	ICFN 25	16.6	36.5	027L4575
ICF 25	4	18	1 ½	40	Butt-weld DIN-EN 10220	ICFS 25	ICFF 25	ICFE 25	ICFN 25	16.6	36.5	027L4165
ICF 25	4	18	1 ½	40	Butt-weld DIN-EN 10220	ICFS 25	ICFF 25E	ICFE 25	ICFN 25	16.6	36.6	027L4177
ICF 15	4	18	½	15	Socket weld, ANSI (B 16.11)	ICFS 15 <sup>(1)</sup>	ICFF 15 <sup>(1)</sup>	ICFE 20	ICFN 20	6.5	14.3	027L4558
ICF 15	4	18H	½	15	Socket weld, ANSI (B 16.11)	ICFS 15 <sup>(1)</sup>	ICFF 15 <sup>(1)</sup>	ICFE 20-H	ICFN 20	7.2	15.8	027L4557
ICF 15	4	18	¾	20	Socket weld, ANSI (B 16.11)	ICFS 15 <sup>(1)</sup>	ICFF 15 <sup>(1)</sup>	ICFE 20	ICFN 20	6.5	14.3	027L4621
ICF 15	4	18H	¾	20	Socket weld, ANSI (B 16.11)	ICFS 15 <sup>(1)</sup>	ICFF 15 <sup>(1)</sup>	ICFE 20-H	ICFN 20	7.2	15.8	027L4620
ICF 15	4	18	¾	20	Socket weld, ANSI (B 16.11)	ICFS 20	ICFF 20E	ICFE 20H	ICFN 20	8	17.6	027L3353
ICF 25	4	18	1	25	Socket weld, ANSI (B 16.11)	ICFS 25	ICFF 25E	ICFE 25	ICFN 25	16.9	37.2	027L4136

## Valve station, type ICF 15, ICF 20, ICF 25, ICF 50 and ICF 65

Type	# of modules	Appl. #	Connection size		Connection type	Module location				Weight		Code number
			[in.]	[mm]		M1	M2	M3	M4	kg	lbs	
ICF 20	4	18H	1	25	Socket weld, ANSI (B 16.11)	ICFS 20	ICFF 20E	ICFE 20H	ICFN 20	8	17.6	027L3354
ICF 20	4	18H	1 ¼	32	Socket weld, ANSI (B 16.11)	ICFS 20	ICFF 20E	ICFE 20H	ICFN 20	8	17.6	027L3355
ICF 25	4	18	1 ¼	32	Socket weld, ANSI (B 16.11)	ICFS 25	ICFF 25E	ICFE 25	ICFN 25	16	35.2	027L4137
ICF 25	4	18	1 ½	40	Socket weld, ANSI (B 16.11)	ICFS 25	ICFF 25E	ICFE 25	ICFN 25	16.2	35.6	027L4138

<sup>(1)</sup> Fixed module

## Liquid PWM

**Table 87: Application 13: Liquid injection & liquid feed PWM**

Type	# of modules	Appl. #	Connection size		Connection type	Module location				Weight		Code number
			[in.]	[mm]		M1	M2	M3	M4	kg	lbs	
ICF 15	4	13	¾	20	Butt-weld ANSI (B 36.10)	ICFS 15 <sup>(1)</sup>	ICFF 15 <sup>(1)</sup>	ICFA 20	ICFN 20	6.2	13.7	027L4555
ICF 15	4	13	¾	20	Butt-weld DIN-EN 10220	ICFS 15 <sup>(1)</sup>	ICFF 15 <sup>(1)</sup>	ICFA 20	ICFN 20	6.2	13.7	027L4523
ICF 20	4	13	¾	20	Butt-weld DIN-EN 10220	ICFS 20	ICFF 20	ICFA 20	ICFN 20	6.8	15	027L3092
ICF 15	4	13	½	15	Socket weld, ANSI (B 16.11)	ICFS 15 <sup>(1)</sup>	ICFF 15 <sup>(1)</sup>	ICFA 20	ICFN 20	6.2	13.7	027L4529
ICF 15	4	13	¾	20	Socket weld, ANSI (B 16.11)	ICFS 15 <sup>(1)</sup>	ICFF 15 <sup>(1)</sup>	ICFA 20	ICFN 20	6.2	13.7	027L4614
ICF 20	4	13	¾	20	Socket weld, ANSI (B 16.11)	ICFS 20	ICFF 20E	ICFA 20	ICFN 20	6.8	15	027L3094
ICF 15	4	13	7/8	22	Solder DIN-EN1254-1	ICFS 15 <sup>(1)</sup>	ICFF 15 <sup>(1)</sup>	ICFA20	ICFN20	6.2	13.7	027L4582

<sup>(1)</sup> Fixed module

## Return lines

**Table 88: Application 41: Return lines - ON/OFF**

Type	# of modules	Appl. #	Connection size		Connection type	Module location				Weight		Code number
			[in.]	[mm]		M1 <sup>(1)</sup>	M2	M3	M4	kg	lbs	
ICF 50	4	41	1 ½	40	Butt-weld DIN-EN 10220	SVA-S 50	ICFB 50	ICLX 50	SVA-S 50	25.5	56.1	027L5021
ICF 50	4	41	2	50	Butt-weld DIN-EN 10220	SVA-S 50	ICFB 50	ICLX 50	SVA-S 50	25.5	56.1	027L5023
ICF 50	4	41	1 ½	40	Socket weld, ANSI (B 16.11)	SVA-S 50	ICFB 50	ICLX 50	SVA-S 50	25.5	56.1	027L5022
ICF 50	4	41	2	50	Socket weld, ANSI (B 16.11)	SVA-S 50	ICFB 50	ICLX 50	SVA-S 50	25.5	56.1	027L5024
ICF 65	3	41	2 ½	65	Butt-weld ANSI (B 36.19)	SVA-S 65		ICLX 65	SVA-S 65	32.7	71.9	027L6522

## Valve station, type ICF 15, ICF 20, ICF 25, ICF 50 and ICF 65

Type	# of modules	Appl. #	Connection size		Connection type	Module location				Weight		Code number
			[in.]	[mm]		M1 <sup>(1)</sup>	M2	M3	M4	kg	lbs	
ICF 65	3	41	3	80	Butt-weld ANSI (B 36.19)	SVA-S 65		ICLX 65	SVA-S 65	32.7	71.9	027L6524
ICF 65	3	41	2 ½	65	Butt-weld DIN-EN 10220	SVA-S 65		ICLX 65	SVA-S 65	32.7	71.9	027L6521
ICF 65	3	41	3	80	Butt-weld DIN-EN 10220	SVA-S 65		ICLX 65	SVA-S 65	32.7	71.9	027L6523

**Table 89: Application 42: Return lines - Pressure (temperature) - Mechanical control**

Type	# of mod	Appl. #	Connection size		Connection type	Module location				Weight		Code number
			[in.]	[mm]		M1 <sup>(1)</sup>	M2	M3	M4	kg	lbs	
ICF 50	4	42S50	1 ½	40	Butt-weld DIN-EN 10220	SVA-S 50	ICFB 50	ICS 50	SVA-S 50	25.8	56.8	027L5001
ICF 50	4	42S32	1 ½	40	Butt-weld DIN-EN 10220	SVA-S 50	ICFB 50	ICS 50-32	SVA-S 50	25.8	56.8	027L5005
ICF 50	4	42S40	1 ½	40	Butt-weld DIN-EN 10220	SVA-S 50	ICFB 50	ICS 50-40	SVA-S 50	25.8	56.8	027L5009
ICF 50	4	42S50	2	50	Butt-weld DIN-EN 10220	SVA-S 50	ICFB 50	ICS 50	SVA-S 50	25.8	56.8	027L5003
ICF 50	4	42S32	2	50	Butt-weld DIN-EN 10220	SVA-S 50	ICFB 50	ICS 50-32	SVA-S 50	25.8	56.8	027L5007
ICF 50	4	42S40	2	50	Butt-weld DIN-EN 10220	SVA-S 50	ICFB 50	ICS 50-40	SVA-S 50	25.8	56.8	027L5011
ICF 50	4	42S50	1 ½	40	Socket weld. ANSI (B 16.11)	SVA-S 50	ICFB 50	ICS 50	SVA-S 50	25.8	56.8	027L5002
ICF 50	4	42S32	1 ½	40	Socket weld. ANSI (B 16.11)	SVA-S 50	ICFB 50	ICS 50-32	SVA-S 50	25.8	56.8	027L5006
ICF 50	4	42S50	2	50	Socket weld. ANSI (B 16.11)	SVA-S 50	ICFB 50	ICS 50	SVA-S 50	25.8	56.8	027L5004
ICF 50	4	42S32	2	50	Socket weld. ANSI (B 16.11)	SVA-S 50	ICFB 50	ICS 50-32	SVA-S 50	25.8	56.8	027L5008
ICF 50	4	42S40	2	50	Socket weld. ANSI (B 16.11)	SVA-S 50	ICFB 50	ICS 50-40	SVA-S 50	25.8	56.8	027L5012
ICF 65	3	42S65	2 ½	65	Butt-weld ANSI (B 36.19)	SVA-S 65		ICS 65	SVA-S 65	33.3	73.3	027L6502
ICF 65	3	42S40	2 ½	65	Butt-weld ANSI (B 36.19)	SVA-S 65		ICS 65-40	SVA-S 65	33.3	73.3	027L6506
ICF 65	3	42S80	2 ½	65	Butt-weld ANSI (B 36.19)	SVA-S 65		ICS 80	SVA-S 65	33.3	73.3	027L6510
ICF 65	3	42S65	3	80	Butt-weld ANSI (B 36.19)	SVA-S 65		ICS 65	SVA-S 65	33.3	73.3	027L6504
ICF 65	3	42S40	3	80	Butt-weld ANSI (B 36.19)	SVA-S 65		ICS 65-40	SVA-S 65	33.3	73.3	027L6508
ICF 65	3	42S80	3	80	Butt-weld ANSI (B 36.19)	SVA-S 65		ICS 80	SVA-S 65	33.3	73.3	027L6512
ICF 65	3	42S65	2 ½	65	Butt-weld DIN-EN 10220	SVA-S 65		ICS 65	SVA-S 65	33.3	73.3	027L6501
ICF 65	3	42S40	2 ½	65	Butt-weld DIN-EN 10220	SVA-S 65		ICS 65-40	SVA-S 65	33.3	73.3	027L6505
ICF 65	3	42S80	2 ½	65	Butt-weld DIN-EN 10220	SVA-S 65		ICS 80	SVA-S 65	33.3	73.3	027L6509
ICF 65	3	42S65	3	80	Butt-weld DIN-EN 10220	SVA-S 65		ICS 65	SVA-S 65	33.3	73.3	027L6503
ICF 65	3	42S40	3	80	Butt-weld DIN-EN 10220	SVA-S 65		ICS 65-40	SVA-S 65	33.3	73.3	027L6507
ICF 65	3	42S80	3	80	Butt-weld DIN-EN 10220	SVA-S 65		ICS 80	SVA-S 65	33.3	73.3	027L6511

Valve station, type ICF 15, ICF 20, ICF 25, ICF 50 and ICF 65

Table 90: Application 43: Return lines - Pressure (temperature) - Electronic control

Type	# of modules	Appl. #	Connection size		Connection type	Module location				Weight		Code number
			[in.]	[mm]		M1 <sup>(1)</sup>	M2	M3	M4	kg	lbs	
ICF 50	4	43MA	1 ½	40	Butt-weld DIN-EN 10220	SVA-S 50	ICFB 50	ICM 50 - A	SVA-S 50	24.8	54.6	027L5013
ICF 50	4	43MB	1 ½	40	Butt-weld DIN-EN 10220	SVA-S 50	ICFB 50	ICM 50 - B	SVA-S 50	24.8	54.6	027L5017
ICF 50	4	43MA	2	50	Butt-weld DIN-EN 10220	SVA-S 50	ICFB 50	ICM 50 - A	SVA-S 50	24.8	54.6	027L5015
ICF 50	4	43MB	2	50	Butt-weld DIN-EN 10220	SVA-S 50	ICFB 50	ICM 50 - B	SVA-S 50	24.8	54.6	027L5019
ICF 50	4	43MA	1 ½	40	Socket weld, ANSI (B 16.11)	SVA-S 50	ICFB 50	ICM 50 - A	SVA-S 50	24.8	54.6	027L5014
ICF 50	4	43MB	1 ½	40	Socket weld, ANSI (B 16.11)	SVA-S 50	ICFB 50	ICM 50 - B	SVA-S 50	24.8	54.6	027L5018
ICF 50	4	43MA	2	50	Socket weld, ANSI (B 16.11)	SVA-S 50	ICFB 50	ICM 50 - A	SVA-S 50	24.8	54.6	027L5016
ICF 50	4	43MB	2	50	Socket weld, ANSI (B 16.11)	SVA-S 50	ICFB 50	ICM 50 - B	SVA-S 50	24.8	54.6	027L5020
ICF 65	3	43MA	2 ½	65	Butt-weld ANSI (B 36.19)	SVA-S 65		ICM 65 - A	SVA-S 65	32.9	72.4	027L6514
ICF 65	3	43MB	2 ½	65	Butt-weld ANSI (B 36.19)	SVA-S 65		ICM 65 - B	SVA-S 65	32.9	72.4	027L6518
ICF 65	3	43MA	3	80	Butt-weld ANSI (B 36.19)	SVA-S 65		ICM 65 - A	SVA-S 65	32.9	72.4	027L6516
ICF 65	3	43MB	3	80	Butt-weld ANSI (B 36.19)	SVA-S 65		ICM 65 - B	SVA-S 65	32.9	72.4	027L6520
ICF 65	3	43MA	2 ½	65	Butt-weld DIN-EN 10220	SVA-S 65		ICM 65 - A	SVA-S 65	32.9	72.4	027L6513
ICF 65	3	43MB	2 ½	65	Butt-weld DIN-EN 10220	SVA-S 65		ICM 65 - B	SVA-S 65	32.9	72.4	027L6517
ICF 65	3	43MA	3	80	Butt-weld DIN-EN 10220	SVA-S 65		ICM 65 - A	SVA-S 65	32.9	72.4	027L6515
ICF 65	3	43MB	3	80	Butt-weld DIN-EN 10220	SVA-S 65		ICM 65 - B	SVA-S 65	32.9	72.4	027L6519

Table 91: Application 44: ON/OFF 2-step solenoid + Manuel Regulating

Type	# of modules	Appl. #	Connection size		Connection type	Module location				Weight		Code number
			[in.]	[mm]		M1 <sup>(1)</sup>	M2	M3	M4	kg	lbs	
ICF 50	4	44	1 ½	40	Butt-weld DIN-EN 10220	SVA-S 50	ICFB 50	ICLX 50	REG 50-B	25.5	56.1	027L5045
ICF 50	4	44	2	50	Butt-weld DIN-EN 10220	SVA-S 50	ICFB 50	ICLX 50	REG 50-B	25.5	56.1	027L5046
ICF 50	4	44	1 ½	40	Socket weld, ANSI (B 16.11)	SVA-S 50	ICFB 50	ICLX 50	REG 50-B	25.5	56.1	027L5047
ICF 50	4	44	2	50	Socket weld, ANSI (B 16.11)	SVA-S 50	ICFB 50	ICLX 50	REG 50-B	25.5	56.1	027L5048

Valve station, type ICF 15, ICF 20, ICF 25, ICF 50 and ICF 65

**Table 92: Application 45: Pressure (temperature) Mechanical control + Manuel Regulating**

Type	# of modules	Appl. #	Connection size		Connection type	Module location				Weight		Code number
			[in.]	[mm]		M1 <sup>(1)</sup>	M2	M3	M4	kg	lbs	
ICF 50	4	45S50	1 ½	40	Butt-weld DIN-EN 10220	SVA-S 50	ICFB 50	ICS 50	REG 50-B	25.8	56.8	027L5025
ICF 50	4	45S32	1 ½	40	Butt-weld DIN-EN 10220	SVA-S 50	ICFB 50	ICS 50-32	REG 50-B	25.8	56.8	027L5029
ICF 50	4	45S40	1 ½	40	Butt-weld DIN-EN 10220	SVA-S 50	ICFB 50	ICS 50-40	REG 50-B	25.8	56.8	027L5033
ICF 50	4	45S50	2	50	Butt-weld DIN-EN 10220	SVA-S 50	ICFB 50	ICS 50	REG 50-B	25.8	56.8	027L5027
ICF 50	4	45S32	2	50	Butt-weld DIN-EN 10220	SVA-S 50	ICFB 50	ICS 50-32	REG 50-B	25.8	56.8	027L5031
ICF 50	4	45S40	2	50	Butt-weld DIN-EN 10220	SVA-S 50	ICFB 50	ICS 50-40	REG 50-B	25.8	56.8	027L5035
ICF 50	4	45S50	1 ½	40	Socket weld, ANSI (B 16.11)	SVA-S 50	ICFB 50	ICS 50	REG 50-B	25.8	56.8	027L5026
ICF 50	4	45S32	1 ½	40	Socket weld, ANSI (B 16.11)	SVA-S 50	ICFB 50	ICS 50-32	REG 50-B	25.8	56.8	027L5030
ICF 50	4	45S40	1 ½	40	Socket weld, ANSI (B 16.11)	SVA-S 50	ICFB 50	ICS 50-40	REG 50-B	25.8	56.8	027L5034
ICF 50	4	45S50	2	50	Socket weld, ANSI (B 16.11)	SVA-S 50	ICFB 50	ICS 50	REG 50-B	25.8	56.8	027L5028
ICF 50	4	45S32	2	50	Socket weld, ANSI (B 16.11)	SVA-S 50	ICFB 50	ICS 50-32	REG 50-B	25.8	56.8	027L5032
ICF 50	4	45S40	2	50	Socket weld, ANSI (B 16.11)	SVA-S 50	ICFB 50	ICS 50-40	REG 50-B	25.8	56.8	027L5036
ICF 65	3	45S65	3	65	Butt-weld DIN-EN 10220	SVA-S 65		ICS 65	REG 65-B	33.3	73.3	027L6525
ICF 65	3	45S65	3	65	Butt-weld DIN-EN 10220	SVA-S 65		ICS 80	REG 65-B	33.3	73.3	027L6526

**Table 93: Application 46: Pressure (temperature) Electronic control + Manual Regulating**

Type	# of modules	Appl. #	Connection size		Connection type	Module location				Weight		Code number
			[in.]	[mm]		M1 <sup>(1)</sup>	M2	M3	M4	kg	lbs	
ICF 50	4	46MA	1 ½	40	Butt-weld DIN-EN 10220	SVA-S 50	ICFB 50	ICM 50-A	REG 50-B	24.8	54.6	027L5037
ICF 50	4	46MB	1 ½	40	Butt-weld DIN-EN 10220	SVA-S 50	ICFB 50	ICM 50-B	REG 50-B	24.8	54.6	027L5041
ICF 50	4	46MA	2	50	Butt-weld DIN-EN 10220	SVA-S 50	ICFB 50	ICM 50-A	REG 50-B	24.8	54.6	027L5039
ICF 50	4	46MB	2	50	Butt-weld DIN-EN 10220	SVA-S 50	ICFB 50	ICM 50-B	REG 50-B	24.8	54.6	027L5043
ICF 50	4	46MA	1 ½	40	Socket weld, ANSI (B 16.11)	SVA-S 50	ICFB 50	ICM 50-A	REG 50-B	24.8	54.6	027L5038

## Valve station, type ICF 15, ICF 20, ICF 25, ICF 50 and ICF 65

Type	# of modules	Appl. #	Connection size		Connection type	Module location				Weight		Code number
			[in.]	[mm]		M1 <sup>(1)</sup>	M2	M3	M4	kg	lbs	
ICF 50	4	46MB	1 ½	40	Socket weld, ANSI (B 16.11)	SVA-S 50	ICFB 50	ICM 50-B	REG 50-B	24.8	54.6	027L5042
ICF 50	4	46MA	2	50	Socket weld, ANSI (B 16.11)	SVA-S 50	ICFB 50	ICM 50-A	REG 50-B	24.8	54.6	027L5040
ICF 50	4	46MB	2	50	Socket weld, ANSI (B 16.11)	SVA-S 50	ICFB 50	ICM 50-B	REG 50-B	24.8	54.6	027L5044

<sup>(1)</sup> Fixed module

### **i** NOTE:

All ICS modules are 3-pilot versions. They are supplied with two blanking plugs (A) and one sealing plug (B) (see [Page 15](#)).

## Miscellaneous

**Table 94: Application 90: Miscellaneous**

Type	# of modules	Appl. #	Connection size		Connection type	Module location						Weight		Code number
			[in.]	[mm]		M1	M2	M3	M4	M5	M6	kg	lbs	
ICF 20	4	90	¾	20	Butt-weld ANSI (B 36.10)	ICFS 20	ICFF 20E	ICFE 20	ICFN 20			7.2	15.8	027L3371
ICF 20	6	90	1	25	Butt-weld ANSI (B 36.10)	ICFS 20	ICFF 20	ICFE 20	ICFC 20	ICFB 20	ICFB 20	10.2	22.5	027L3420
ICF 20	6	90	1	25	Butt-weld ANSI (B 36.10)	ICFS 20	ICFF 20	ICFE 20	ICFS 20	ICFB 20	ICFB 20	9.7	21.4	027L3421
ICF 20	4	90	¾	20	Butt-weld DIN-EN 10220	ICFR 20A	ICFF 20	ICFA 20	ICFN 20			6.4	14.1	027L3156
ICF 20	4	90	¾	20	Butt-weld DIN-EN 10220	ICFR 20A	ICFF 20	ICFE 20	ICFN 20			6.4	14.1	027L3155
ICF 20	4	90	¾	20	Butt-weld DIN-EN 10220	ICFS 20	ICFF 20	ICFE 20	ICFN 20			7.2	15.8	027L3379
ICF 20	4	90	¾	20	Butt-weld DIN-EN 10220	ICFS 20	ICFW 20-D	ICFE 20	ICFS 20			5.9	13	027L3385
ICF 20	4	90	¾	20	Butt-weld DIN-EN 10220	ICFS 20	ICFF 20	ICFB 20	ICFC 20			5.9	13	027L3141
ICF 20	4	99	¾	20	Butt-weld DIN-EN 10220	ICFS 20	ICFF 20	ICFE 20	ICFB 20			6.2	13.7	027L3122
ICF 20	4	99	¾	20	Butt-weld DIN-EN 10220	ICFS 20	ICFF 20	ICFE 20	ICFO 20			6.1	13.4	027L3359
ICF 20	4	99	¾	20	Butt-weld DIN-EN 10220	ICFS 20	ICFF 20	ICFE 20	ICFR 20A			6.7	14.8	027L3700
ICF 20	4	90	¾	20	Butt-weld DIN-EN 10220	ICFS 20	ICFF 20	ICFB 20	ICFN 20			6.7	14.8	027L3405
ICF 15	4	90	½	15	Butt-weld DIN-EN 10220	ICFS 15 <sup>(1)</sup>	ICFF 15 <sup>(1)</sup>	ICFB 20	ICFN 20			6.7	14.8	027L4581
ICF 15	4	90	¾	20	Butt-weld DIN-EN 10220	ICFS 15 <sup>(1)</sup>	ICFF 15 <sup>(1)</sup>	ICFR 20A	ICFN 20			7.2	15.8	027L4576
ICF 20	6	90	¾	20	Butt-weld DIN-EN 10220	ICFS 20	ICFF 20	ICFE 20	ICFO 20	ICFA 20	ICFS 20	9.4	20.7	027L3053

## Valve station, type ICF 15, ICF 20, ICF 25, ICF 50 and ICF 65

Type	# of modules	Appl. #	Connection size		Connection type	Module location						Weight		Code number
			[in.]	[mm]		M1	M2	M3	M4	M5	M6	kg	lbs	
ICF 20	6	90	3/4	20	Butt-weld DIN-EN 10220	ICFS 20	ICFF 20	ICFA 20	ICFC 20	ICFB 20	ICFS 20	9.9	21.8	027L3056
ICF 20	6	90	3/4	20	Butt-weld DIN-EN 10220	ICFS 20	ICFF 20	ICFE 20	ICFO 20	ICM 20-A	ICFN 20	9.7	21.3	027L3372
ICF 20	6	90	3/4	20	Butt-weld DIN-EN 10220	ICFS 20	ICFF 20	ICFE 20	ICFB 20	ICFR 20-A	ICFN 20	9.7	21.3	027L3133
ICF 20	6	90	3/4	20	Butt-weld DIN-EN 10220	ICFS 20	ICFF 20	ICFE 20	ICFC 20	ICFB 20	ICFR 20A	9.4	20.7	027L3144
ICF 20	6	90	3/4	20	Butt-weld DIN-EN 10220	ICFS 20	ICFF 20	ICFE 20	ICFC 20	ICM 20-C	ICFS 20	9.7	21.3	027L3152
ICF 20	6	90	3/4	20	Butt-weld DIN-EN 10220	ICFS 20	ICFF 20	ICFE 20	ICFO 20	ICFS 20	ICFC 20	9.8	21.6	027L3360
ICF 20	6	90	3/4	20	Butt-weld DIN-EN 10220	ICFB 20	ICFC 20	ICFE 20	ICFO 20	ICFS 20	ICFB 20	6.2	13.6	027L3121
ICF 20	6	90	3/4	20	Butt-weld DIN-EN 10220	ICFS 20	ICFF 20	ICFE 20H	ICFC 20	ICFB 20	ICFS 20	9.6	21.1	027L3387
ICF 20	6	90	3/4	20	Butt-weld DIN-EN 10220	ICFS 20	ICFF 20	ICFE 20	ICFC 20	ICFR 20A	ICFW 20D	9.1	20.1	027L3368
ICF 20	6	90	3/4	20	Butt-weld DIN-EN 10220	ICFS 20	ICFF 20	ICFE 20H	ICFC 20	ICFR 20A	ICFS 20	10.2	22.5	027L3386
ICF 20	6	90	3/4	20	Butt-weld DIN-EN 10220	ICFS 20	ICFF 20	ICFE 20	ICFC 20	ICM 20B	ICFS 20	9.7	21.4	027L3397
ICF 20	6	90	3/4	20	Butt-weld DIN-EN 10220	ICFS 20	ICFF 20	ICFE 20	ICFC 20	ICFB 20	ICFS 20	9.4	20.7	027L3424
ICF 20	6	90	3/4	20	Butt-weld DIN-EN 10220	ICFS 20	ICFF 20	ICFE 20	ICFO 20	ICM 20B	ICFN 20	9.6	21.1	027L3425
ICF 20	6	99	3/4	20	Butt-weld DIN-EN 10220	ICFS 20	ICFF 20	ICFE 20	ICFC 20	ICFB 20	ICFR 20A	9.4	20.7	027L3701
ICF 20	6	90	3/4	20	Butt-weld DIN-EN 10220	ICFS 20	ICFF 20E	ICFE 20	ICFN 20	ICFR 20B	ICFW 20D	9.1	20.1	027L3439
ICF 20	6	90	3/4	20	Butt-weld DIN-EN 10220	ICFS 20	ICFF 20	ICFE 20	ICFC 20	ICFW 20D	ICFS 20	9.1	20.1	027L3441
ICF 20	6	90	3/4	20	Butt-weld DIN-EN 10220	ICFS 20	ICFF 20	ICFE 20	ICFO 20	ICFB 20	ICFN 20	9.4	20.7	027L3446
ICF 20	6	90	3/4	20	Butt-weld DIN-EN 10220	ICFS 20	ICFF 20	ICFE 20	ICFC 20	ICFR 20B	ICFW 20D	9.1	20.1	027L3447
ICF 20	4	90	1	25	Butt-weld DIN-EN 10220	ICFS 20	ICFF 20	ICFE 20	ICFN 20			6.7	14.7	027L3134
ICF 20	4	90	1	25	Butt-weld DIN-EN 10220	ICFS 20	ICFF 20	ICFE 20	ICFB 20			5.9	13	027L3364
ICF 20	4	90	1	25	Butt-weld DIN-EN 10220	ICFS 20	ICFF 20	ICFE 20H	ICFN 20			7.2	15.8	027L3380
ICF 20	6	90	1	25	Butt-weld DIN-EN 10220	ICFS 20	ICFF 20	ICFE 20	ICFO 20	ICFA 20	ICFS 20	9.8	21.6	027L3361



## Valve station, type ICF 15, ICF 20, ICF 25, ICF 50 and ICF 65

Type	# of modules	Appl. #	Connection size		Connection type	Module location						Weight		Code number
			[in.]	[mm]		M1	M2	M3	M4	M5	M6	kg	lbs	
ICF 20	6	90	1	25	Butt-weld DIN-EN 10220	ICFS 20	ICFF 20	ICFE 20	ICFC 20	ICFR 20A	ICFB 20	9.1	20	027L3363
ICF 20	6	90	1	25	Butt-weld DIN-EN 10220	ICFS 20	ICFF 20	ICFE 20H	ICFC 20	ICFR 20B	ICFW 20D	12	26.4	027L3376
ICF 20	6	90	1	25	Butt-weld DIN-EN 10220	ICFS 20	ICFF 20E	ICFE 20H	ICFC 20	ICFR 20B	ICFW 20D	11.5	25.3	027L3375

<sup>1)</sup> Fixed module

**Table 95: Application 90: Miscellaneous**

Type	# of modules	Appl. #	Connection size		Connection type	Module location						Weight		Code number
			[in.]	[mm]		M1	M2	M3	M4	M5	M6	kg	lbs	
ICF 20	4	90		20	Butt-weld DIN-EN 10220	ICFB 20	ICFD 20C	ICFE 20	ICFB 20					027L3599
ICF 20	4	90		25	Butt-weld DIN-EN 10220	ICFB 20	ICFD 20C	ICFE 20	ICFB 20					027L3600
ICF 20	6	90	1	25	Butt-weld DIN-EN 10220	ICFS 20	ICFF 20	ICFE 20	ICFC 20	ICFB 20	ICFS 20	9.4	20.7	027L3123
ICF 25	6	90	1	25	Butt-weld DIN-EN 10220	ICFS 25	ICFF 25	ICFE 25	ICFC 25	ICFR 25B	ICFW 25D	23.6	51.9	027L4168
ICF 25	6	90	1	25	Butt-weld DIN-EN 10220	ICFS 25	ICFF 25	ICFE 25	ICFC 25	ICFS 25	ICFB 25	22	48.4	027L4151
ICF 20	6	90	1	25	Butt-weld DIN-EN 10220	ICFS 20	ICFF 20	ICFE 20	ICFC 20	ICFR 20A	ICFW 20D	9	19.8	027L3369
ICF 20	6	90	1	25	Butt-weld DIN-EN 10220	ICFS 20	ICFF 20	ICFE 20	ICFO 20	ICFA 20	ICFC 20	9.6	21.1	027L3396
ICF 20	6	90	1	25	Butt-weld DIN-EN 10220	ICFS 20	ICFF 20E	ICFE 20H	ICFC 20	ICFR 20A	ICFB 20	9.7	21.4	027L3423
ICF 20	6	90	1	25	Butt-weld DIN-EN 10220	ICFS 20	ICFF 20	ICFE 20	ICFO 20	ICM 20B	ICFN 20	9.6	21.1	027L3426
ICF 25	6	90	1	25	Butt-weld DIN-EN 10220	ICFS 25	ICFF 25E	ICFE 25	ICFC 25	ICFR 25B	ICFB 25	23.6	52	027L4176
ICF 25	6	90	1	25	Butt-weld DIN-EN 10220	ICFS 25	ICFF 25E	ICFE 25	ICFC 25	ICFR 25B	ICFF 25	23.8	52.4	027L4577
ICF 25	6	90	1	25	Butt-weld DIN-EN 10220	ICFS 25	ICFF 25E	ICFE 25	ICFN 25	ICFR 25B	ICFW 25D	22.7	49.9	027L4186
ICF 25	6	90	1 ¼	32	Butt-weld DIN-EN 10220	ICFS 25	ICFF 25	ICFE 25	ICFC 25	ICFR 25B	ICFB 25	21.7	47.7	027L4143
ICF 25	6	90	1 ¼	32	Butt-weld DIN-EN 10220	ICFS 25	ICFF 25E	ICFE 25	ICFC 25	ICFR 25B	ICFW 25D	22.7	49.9	027L4160
ICF 25	6	90	1 ¼	32	Butt-weld DIN-EN 10220	ICFS 25	ICFF 25	ICFE 25	ICFC 25	ICFR 25B	ICFW 25D	21.9	48.2	027L4161
ICF 25	6	90	1 ¼	32	Socket weld, ANSI (B 16.11)	ICFS 25	ICFF 25E	ICFE 25	ICFC 25	ICFB 25	ICFS 25	21.9	48.2	027L4162
ICF 25	6	90	1 ¼	32	Butt-weld DIN-EN 10220	ICFS 25	ICFF 25-E	ICFE 25	ICFC 25	ICFR 25B	ICFB 25	22.7	49.9	027L4178

## Valve station, type ICF 15, ICF 20, ICF 25, ICF 50 and ICF 65

Type	# of modules	Appl. #	Connection size		Connection type	Module location						Weight		Code number
			[in.]	[mm]		M1	M2	M3	M4	M5	M6	kg	lbs	
ICF 25	6	90	1 ½	40	Butt-weld DIN-EN 10220	ICFS 25	ICFF 25	ICFE 25	ICFC 25	ICFR 25A	ICFW 25D	23.6	51.9	027L4157
ICF 25	6	90	1 ½	40	Butt-weld DIN-EN 10220	ICFS 25	ICFF 25E	ICFE 25	ICFC 25	ICFR 25B	ICFW 25D	23.6	51.9	027L4166
ICF 25	6	90	1 ½	40	Butt-weld DIN-EN 10220	ICFS 25	ICFF 25	ICFE 25	ICFC 25	ICFR 25B	ICFW 25D	21.7	47.7	027L4167
ICF 25	4	90	1 ½	40	Butt-weld DIN-EN 10220	ICFS 25	ICFF 25	ICM 25A	ICFB 25	14.9	32.8			027L4185
ICF 25	4	90	1 ½	40	Butt-weld DIN-EN 10220	ICFS 25	ICFF 25	ICFE 25	ICFR 25A			16.1	35.4	027L4192
ICF 20	4	90	¾	20	Socket weld, ANSI (B 16.11)	ICFS 20	ICFF 20E	ICM 20- A33	ICFB 20			7.2	15.8	027L3362
ICF 20	4	90	1	25	Socket weld, ANSI (B 16.11)	ICFR 20A	ICFF 20E	ICFE 20	ICFN 20			7.2	15.8	027L4179
ICF 20	4	90	1	25	Socket weld, ANSI (B 16.11)	ICFR 20B	ICFF 20E	ICFE 20H	ICFN 20			7.9	17.4	027L4578
ICF 20	4	90	1	25	Socket weld, ANSI (B 16.11)	ICFB 20	ICFF 20	ICFE 20	ICFN 20			7	15.4	027L3357
ICF 25	4	90	1	25	Socket weld, ANSI (B 16.11)	ICFB 25	ICFF 25E	ICFE 25	ICFN 25			14.1	31	027L4149
ICF 25	4	90	1	25	Socket weld, ANSI (B 16.11)	ICFS 25	ICFF 25E	ICFB 25	ICFR 25A			16.1	35.5	027L4180
ICF 25	4	90	1 ½	40	Socket weld, ANSI (B 16.11)	ICFS 25	ICFF 25E	ICFB 25	ICFR 25A			16.1	35.5	027L4181
ICF 20	4	90	¾		Socket weld, ANSI (B 16.11)	ICFB 20	ICFD 20C	ICFE 20	ICFB 20					027L3605
ICF 20	6	90	¾	20	Socket weld, ANSI (B 16.11)	ICFS 20	ICFF 20E	ICFE 20	ICFO 20	ICFA 20	ICFS 20	9.3	20.5	027L3055
ICF 20	6	90	¾	20	Socket weld, ANSI (B 16.11)	ICFS 20	ICFF 20E	ICFA 20	ICFC 20	ICFB 20	ICFS 20	9.9	21.8	027L3058
ICF 20	6	90	¾	20	Socket weld, ANSI (B 16.11)	ICFS 20	ICFF 20E	ICFE 20	ICFO 20	ICFB 20	ICFN 20	9.4	20.7	027L3150
ICF 20	6	90	¾	20	Socket weld, ANSI (B 16.11)	ICFS 20	ICFF 20E	ICFE 20H	ICFC 20	ICFW 20S	ICFS 20	10.4	22.9	027L4153
ICF 20	4	90	1		Socket weld, ANSI (B 16.11)	ICFB 20	ICFD 20C	ICFE 20	ICFB 20					027L3606
ICF 20	6	90	1	25	Socket weld, ANSI (B 16.11)	ICFS 20	ICFF 20E	ICFE 20H	ICFC 20	ICFW 20S	ICFS 20	11.5	25.3	027L3377
ICF 25	6	90	1	25	Socket weld, ANSI (B 16.11)	ICFS 25	ICFF 25E	ICFE 25	ICFC 25	ICFB 25	ICFS 25	23.1	50.8	027L4156
ICF 25	6	90	1	25	Socket weld, ANSI (B 16.11)	ICFS 25	ICFF 25E	ICFE 25	ICFC 25	ICFW 25S	ICFS 25	25.1	55.2	027L4158
ICF 20	6	90	1 ¼	32	Socket weld, ANSI (B 16.11)	ICFS 20	ICFF 20E	ICFE 20H	ICFC 20	ICFB 20	ICFS 20	10.5	23.1	027L3378
ICF 20	6	90	1 ¼	32	Socket weld, ANSI (B 16.11)	ICFS 20	ICFF 20E	ICFE 20H	ICFC 20	ICFW 20S	ICFS 20	10.5	23.1	027L4152

## Valve station, type ICF 15, ICF 20, ICF 25, ICF 50 and ICF 65

Type	# of modules	Appl. #	Connection size		Connection type	Module location						Weight		Code number
			[in.]	[mm]		M1	M2	M3	M4	M5	M6	kg	lbs	
ICF 25	6	90	1 1/4	32	Socket weld, ANSI (B 16.11)	ICFS 25	ICFF 25E	ICFE 25	ICFC 25	ICFW 25S	ICFS 25	25.1	55.2	027L4154
ICF 25	6	90	1 1/2	40	Socket weld, ANSI (B 16.11)	ICFS 25	ICFF 25E	ICFE 25	ICFC 25	ICFW 25S	ICFS 25	25.1	55.2	027L4159
ICF 20	4	90	3/4	20	Butt-weld DIN-EN 10220	ICFB 20	ICFD 20	ICFE 20	ICFB 20			12.4	27.3	027L3483
ICF 20	4	90	1	25	Butt-weld DIN-EN 10220	ICFB 20	ICFD 20	ICFE 20	ICFB 20			12.4	27.3	027L3484
ICF 20	4	90	1 1/4	32	Butt-weld DIN-EN 10220	ICFB 20	ICFD 20	ICFE 20	ICFB 20			12.4	27.3	027L3485
ICF 20	4	90	3/4	20	Butt-weld DIN-EN 10220	ICFS 20	ICFD 20	ICFE 20	ICFN 20			12.1	26.7	027L3711
ICF 20	6	90	3/4	20	Socket weld, ANSI (B 16.11)	ICFS 20	ICFB 20	ICFE 20	ICFD 20	ICFB 20	ICFS 20	15	33.1	027L3463
ICF 20	6	90	1	25	Socket weld, ANSI (B 16.11)	ICFS 20	ICFB 20	ICFE 20	ICFD 20	ICFB 20	ICFS 20	15	33.1	027L3464
ICF 20	6	90	1 1/4	32	Socket weld, ANSI (B 16.11)	ICFS 20	ICFB 20	ICFE 20	ICFD 20	ICFB 20	ICFS 20	15	33.1	027L3465

### NOTE:

For special applications that cannot be covered by our predefined ICF code numbers please consult Coolselector<sup>®2</sup> or your local Danfoss Sales company. [Coolselector<sup>®2</sup>](#)

Prior to designing „non standard“ configurations there are some basic restrictions to the location of the function modules that must be followed (see [Page 75](#)).

## Defrost drain line

**Table 96: Application 101D1P1 (Ammonia): Liquid drain M2, loaded check valve without solenoid - 1 shut-off**

Type	# of modules	Appl. #	Connection size		Connection type	Module location				Weight		Code number
			[in.]	[mm]		M1	M2	M3	M4	kg	lbs	
ICF 20	4	101	3/4	20	Socket weld, ANSI (B 16.11)	ICFS 20	ICFD 20	ICFB 20	ICFC 20P1	12.6	27.7	027L3628
ICF 20	4	101	1	25	Socket weld, ANSI (B 16.11)	ICFS 20	ICFD 20	ICFB 20	ICFC 20P2	12.6	27.7	027L3629
ICF 20	4	101	1 1/4	32	Socket weld, ANSI (B 16.11)	ICFS 20	ICFD 20	ICFB 20	ICFC 20P3	12.6	27.7	027L3630

**Table 97: Application 102D1 (Ammonia): Liquid drain M2 with solenoid - 2 shut-off**

Type	# of modules	Appl. #	Connection size		Connection type	Module location				Weight		Code number
			[in.]	[mm]		M1	M2	M3	M4	kg	lbs	
ICF 20	4	102	3/4	20	Butt-weld DIN-EN 10220	ICFS 20	ICFD 20	ICFE 20	ICFS 20	12.7	28	027L3489
ICF 20	4	102	1	25	Butt-weld DIN-EN 10220	ICFS 20	ICFD 20	ICFE 20	ICFS 20	12.7	28	027L3490
ICF 20	4	102	1 1/4	32	Butt-weld DIN-EN 10220	ICFS 20	ICFD 20	ICFE 20	ICFS 20	12.7	28	027L3491
ICF 20	4	102	3/4	20	Socket weld, ANSI (B 16.11)	ICFS 20	ICFD 20	ICFE 20	ICFS 20	13.2	29.1	027L3480
ICF 20	4	102	1	25	Socket weld, ANSI (B 16.11)	ICFS 20	ICFD 20	ICFE 20	ICFS 20	13.1	29.1	027L3481
ICF 20	4	102	1 1/4	32	Socket weld, ANSI (B 16.11)	ICFS 20	ICFD 20	ICFE 20	ICFS 20	12.5	27.6	027L3482

**Table 98: Application 102D2 (CO<sub>2</sub>): Liquid drain M2 with solenoid - 2 shut-off**

Type	# of modules	Appl. #	Connection size		Connection type	Module location				Code number
			[in.]	[mm]		M1	M2	M3	M4	
ICF 20	4	102	¾	20	Butt-weld DIN-EN 10220	ICFS 20	ICFD 20C	ICFE 20	ICFS 20	027L3601
ICF 20	4	102	1	25	Butt-weld DIN-EN 10220	ICFS 20	ICFD 20C	ICFE 20	ICFS 20	027L3602
ICF 20	4	102	1 ¼	32	Butt-weld DIN-EN 10220	ICFS 20	ICFD 20C	ICFE 20	ICFS 20	027L3612
ICF 20	4	102	¾	20	Socket weld, ANSI (B 16.11)	ICFS 20	ICFD 20C	ICFE 20	ICFS 20	027L3607
ICF 20	4	102	1	25	Socket weld, ANSI (B 16.11)	ICFS 20	ICFD 20C	ICFE 20	ICFS 20	027L3608

**Table 99: Application 103D1 (Ammonia): Liquid drain M4 with solenoid - 1 shut-off**

Type	# of modules	Appl. #	Connection size		Connection type	Module location				Weight		Code number
			[in.]	[mm]		M1	M2	M3	M4	kg	lbs	
ICF 20	4	103	¾	20	Socket weld, ANSI (B 16.11)	ICFS 20	ICFB 15	ICFE 20	ICFD 20	12.6	27.8	027L3460
ICF 20	4	103	1	25	Socket weld, ANSI (B 16.11)	ICFS 20	ICFB 20	ICFE 20	ICFD 20	12.5	27.8	027L3461
ICF 20	4	103	1 ¼	32	Socket weld, ANSI (B 16.11)	ICFS 20	ICFB 20E	ICFE 20	ICFD 20	11.9	26.2	027L3462

**Table 100: Application 104D1 (Ammonia): Liquid drain M4 with strainer and solenoid - 1 shut-off**

Type	# of modules	Appl. #	Connection size		Connection type	Module location				Weight		Code number
			[in.]	[mm]		M1	M2	M3	M4	kg	lbs	
ICF 15	4	104	¾	20	Butt-weld DIN-EN 10220	ICFS 15 <sup>(1)</sup>	ICFF 15 <sup>(1)</sup>	ICFE 20	ICFD 20	13.6	30	027L4589
ICF 20	4	104	1	25	Butt-weld DIN-EN 10220	ICFS 20	ICFF 20	ICFE 20	ICFD 20	12.1	26.7	027L3597
ICF 20	4	104	1 ¼	32	Butt-weld DIN-EN 10220	ICFS 20	ICFF 20E	ICFE 20	ICFD 20	12.6	27.7	027L3170

<sup>(1)</sup> Fixed Module

**Table 101: Application 104D2 (CO<sub>2</sub>): Liquid drain M4 with strainer and solenoid - 1 shut-off**

Type	# of modules	Appl. #	Connection size		Connection type	Module location				Code number
			[in.]	[mm]		M1	M2	M3	M4	
ICF 15	4	104	¾	20	Butt-weld DIN-EN 10220	ICFS 15 <sup>(1)</sup>	ICFF 15 <sup>(1)</sup>	ICFE 20	ICFD 20C	027L3611

<sup>(1)</sup> Fixed Module

**Table 102: Application 105D1 (Ammonia): Liquid drain M2 with solenoid - 1 shut-off**

Type	# of modules	Appl. #	Connection size		Connection type	Module location				Weight		Code number
			[in.]	[mm]		M1	M2	M3	M4	kg	lbs	
ICF 20	4	105	¾	20	Butt-weld DIN-EN 10220	ICFS 20	ICFD 20	ICFE 20	ICFB 20	12.1	26.7	027L3486
ICF 20	4	105	1	25	Butt-weld DIN-EN 10220	ICFS 20	ICFD 20	ICFE 20	ICFB 20	12.1	26.7	027L3487
ICF 20	4	105	1 ¼	32	Butt-weld DIN-EN 10220	ICFS 20	ICFD 20	ICFE 20	ICFB 20	12.1	26.7	027L3488

**Table 103: Application 105D2 (CO<sub>2</sub>): Liquid drain M2 with solenoid - 1 shut-off**

Type	# of modules	Appl. #	Connection size		Connection type	Module location				Code number
			[in.]	[mm]		M1	M2	M3	M4	
ICF 20	4	105	¾	20	Butt-weld DIN-EN 10220	ICFS 20	ICFD 20C	ICFE 20	ICFB 20	027L3603
ICF 20	4	105	1	25	Butt-weld DIN-EN 10220	ICFS 20	ICFD 20C	ICFE 20	ICFB 20	027L3604

**Table 104: Application 106D1 (Ammonia): Liquid drain M2 with solenoid and manual opener - 1 shut off**

Type	# of modules	Appl. #	Connection size		Connection type	Module location				Weight		Code number
			[in.]	[mm]		M1	M2	M3	M4	kg	lbs	
ICF 20	4	106	¾	20	Socket weld, ANSI (B 16.11)	ICFS 20	ICFD 20	ICFE 20	ICFO 20	12.9	28.0	027L3551
ICF 20	4	106	1	25	Socket weld, ANSI (B 16.11)	ICFS 20	ICFD 20	ICFE 20	ICFO 20	12.9	28.4	027L3496
ICF 20	4	106	1 ¼	32	Socket weld, ANSI (B 16.11)	ICFS 20	ICFD 20	ICFE 20	ICFO 20	12.9	28.4	027L3497

## Valve station, type ICF 15, ICF 20, ICF 25, ICF 50 and ICF 65

**Table 105: Application 107D1 (Ammonia): Liquid drain M2 with solenoid and manual opener - 2 shut off**

Type	# of modules	Appl. #	Connection size		Connection type	Module location						Weight		Code number
			[in.]	[mm]		M1	M2	M3	M4	M5	M6	kg	lbs	
ICF 20	6	107	¾	20	Socket weld, ANSI (B 16.11)	ICFS 20	ICFD 20	ICFE 20	ICFO 20	ICFB 20	ICFS 20	15.7	34.5	027L3498
ICF 20	6	107	1	25	Socket weld, ANSI (B 16.11)	ICFS 20	ICFD 20	ICFE 20	ICFO 20	ICFB 20	ICFS 20	15.7	34.5	027L3499
ICF 20	6	107	1 ¼	32	Socket weld, ANSI (B 16.11)	ICFS 20	ICFD 20	ICFE 20	ICFO 20	ICFB 20	ICFS 20	15.7	34.5	027L3550

**Table 106: Application 108D1 (Ammonia): Liquid drain M2 without solenoid - 2 shut off**

Type	# of modules	Appl. #	Connection size		Connection type	Module location				Weight		Code number
			[in.]	[mm]		M1	M2	M3	M4	kg	lbs	
ICF 20	4	108	¾	20	Socket weld, ANSI (B 16.11)	ICFS 20	ICFD 20	ICFB 20	ICFS 20	11.9	26.2	027L3558
ICF 20	4	108	1	25	Socket weld, ANSI (B 16.11)	ICFS 20	ICFD 20	ICFB 20	ICFS 20	11.9	26.2	027L3559
ICF 20	4	108	1 ¼	32	Socket weld, ANSI (B 16.11)	ICFS 20	ICFD 20	ICFB 20	ICFS 20	11.9	26.2	027L3560

**Table 107: Application 109D2 (CO<sub>2</sub>): Liquid drain M2 with solenoid and stop/check - 1 shut off**

Type	# of modules	Appl. #	Connection size		Connection type	Module location				Code number
			[in.]	[mm]		M1	M2	M3	M4	
ICF 20	4	109	¾	20	Butt-weld DIN-EN 10220	ICFS 20	ICFD 20C	ICFE 20	ICFN 20	027L3609
ICF 20	4	109	1	25	Butt-weld DIN-EN 10220	ICFS 20	ICFD 20C	ICFE 20	ICFN 20	027L3610

**Table 108: Application 110D1P1 (Ammonia): Liquid drain M2, loaded check valve without solenoid - 2 shut-off**

Type	# of modules	Appl. #	Connection size		Connection type	Module location						Weight		Code number
			[in.]	[mm]		M1	M2	M3	M4	M5	M6	kg	lbs	
ICF 20	6	110	¾	20	Socket weld, ANSI (B 16.11)	ICFS 20	ICFD 20	ICFB 20	ICFC 20P1	ICFB 20	ICFS 20	12.6	27.7	027L3625
ICF 20	6	110	1	25	Socket weld, ANSI (B 16.11)	ICFS 20	ICFD 20	ICFB 20	ICFC 20P1	ICFB 20	ICFS 20	12.6	27.7	027L3626
ICF 20	6	110	1 ¼	32	Socket weld, ANSI (B 16.11)	ICFS 20	ICFD 20	ICFB 20	ICFC 20P1	ICFB 20	ICFS 20	12.6	27.7	027L3627

## Accessories

**Table 109: Stop valve type SNV-ST**

Description	Code no.
G½ in. (Qty. 1)	148B3778
NPT-FPT 3/8 in. (Qty. 1)	148B3747

### NOTE:

Other SNV types see literature: AI244986497087.

For complete list of Spare parts and accessories for ICF 15 to 65 (including SS versions) please refer to [AI242886444256](#)

**Table 110: ICAD 600A/ICAD 1200A**

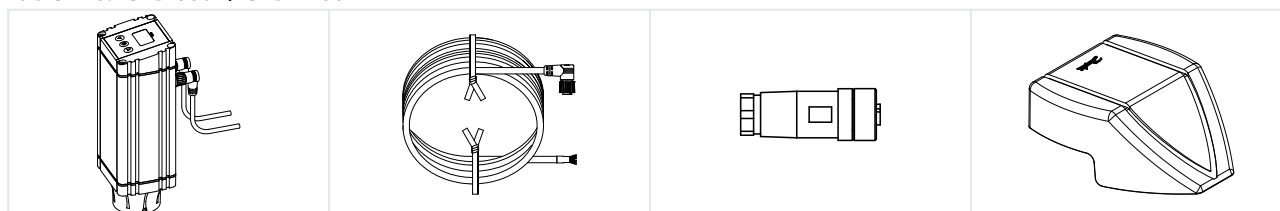

**Table 111: ICAD 600A/ICAD 1200A**

Description	Code no.
ICAD 600A for ICF 15 to ICF 25	With 1.5 m. cables 027H9075
	Without cables 027H9120
ICAD 1200A for ICF 50 and ICF 65	With 1.5 m. cables 027H9077
	Without cables 027H9122

## Valve station, type ICF 15, ICF 20, ICF 25, ICF 50 and ICF 65

Description	Code no.
Cable	Cable set 10 m. 027H0427
	Cable set 15 m. 027H0435
Connector	Connector set female 027H0430
Protection cap	Protection cap for ICAD 027H0431

**NOTE:**

ICAD details see literature: AI236186442940

**Table 112: Coils**

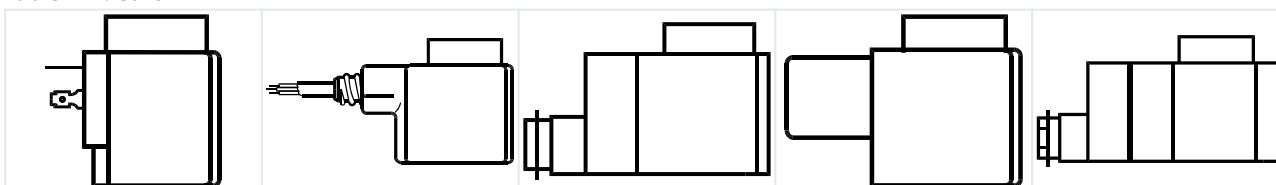

**Table 113: Coils**

Valve type	Voltage	Frequency	Code no.			Appendix no.	Power consumption
	V	Hz	With 1 m 3-core cable IP 67	With terminal box IP 67	With DIN plugs		
<b>Alternating current AC</b>							
ICFE ICS/ICLX (MOPD < 21 Bar)	12	50		<b>018F6706</b>		15	Holding: 10 W 21 VA Inrush: 44 VA
	24	50	<b>018F6257</b>	<b>018F6707</b>	<b>018F7358</b>	16	
	220 – 230	50	<b>018F6251</b>	<b>018F6701</b>	<b>018F7351</b>	31	
	115	60	<b>018F6260</b>	<b>018F6710</b>		20	
<b>Direct current DC</b>							
ICFE/ICFA ICS/ICLX (MOPD < 21 Bar)	12			<b>018F6856</b>		1	20 W
	24			<b>018F6857</b>		2	
<b>Alternating current AC</b>							
ICFE ICS/ICLX (MOPD < 21 Bar)	24	50		<b>018F6807</b>		16	Holding: 12 W 26 VA Inrush: 55 VA
	110	50		<b>018F6811</b>		22	
	220-230	50		<b>018F6801</b>		31	

**NOTE:**

For other coil types please refer to the technical leaflets for **EVRA, AKVA, ICS** or **ICLX** valves.

### Possible module locations

Module locations are indicated by M1, M2, M3, M4, M5 and M6.

With respect to refrigerant flow, M1 is closest to inlet.

**Table 114: ICF 15 with four modules**

Function Module Type		Can be installed in these locations			
ICFS	Shut-off valve module	(ICFS 15) <sup>(1)</sup>	(ICFS 15) <sup>(1)</sup>	( <sup>(2)</sup> )	M4
ICFR	Manual regulating valve module	(ICFS 15) <sup>(1)</sup>	(ICFS 15) <sup>(1)</sup>	( <sup>(2)</sup> )	M4
ICFF	Strainer module	(ICFS 15) <sup>(1)</sup>	(ICFS 15) <sup>(1)</sup>	( <sup>(2)</sup> )	( <sup>(2)</sup> )
ICFE	Solenoid valve module	(ICFS 15) <sup>(1)</sup>	(ICFS 15) <sup>(1)</sup>	M3	( <sup>(2)</sup> )
ICFC	Check valve module	(ICFS 15) <sup>(1)</sup>	(ICFS 15) <sup>(1)</sup>	( <sup>(2)</sup> )	M4
ICFN	Stop & check valve module	(ICFS 15) <sup>(1)</sup>	(ICFS 15) <sup>(1)</sup>	( <sup>(2)</sup> )	M4
ICM	Motor operated valve module	(ICFS 15) <sup>(1)</sup>	(ICFS 15) <sup>(1)</sup>	M3	( <sup>(2)</sup> )
ICFB	Blind top cover	(ICFS 15) <sup>(1)</sup>	(ICFS 15) <sup>(1)</sup>	M3	M4
ICFA	Electronic expansion valve module (for ICF 20 only)	(ICFS 15) <sup>(1)</sup>	(ICFS 15) <sup>(1)</sup>	M3	( <sup>(2)</sup> )
ICFO	Manual opening module	(ICFS 15) <sup>(1)</sup>	(ICFS 15) <sup>(1)</sup>	( <sup>(2)</sup> )	M4
ICFW	Welding module	(ICFS 15) <sup>(1)</sup>	(ICFS 15) <sup>(1)</sup>	M3	M4
ICFD	Drain module (for ICF 15 and 20 only)	(ICFS 15) <sup>(1)</sup>	(ICFS 15) <sup>(1)</sup>	( <sup>(2)</sup> )	M4

## Valve station, type ICF 15, ICF 20, ICF 25, ICF 50 and ICF 65

**Table 115: ICF 20 with two modules**

Function Module Type		Port	
ICFE/ICFA	Solenoid valve module	M1	(2)
ICFE20H	Solenoid valve module (Not in combination with ICFO)	M1	(2)
ICFO	Manual opening module	(2)	M2
ICFB	Blank top cover	M1	M2
ICFW	Welding module	M1	M2
ICFC	Check valve module	(2)	M2
ICFC 20P1	Check valve module	(2)	M2
ICFN 20	Stop & check valve module	(2)	M2
ICFR	Manual regulating valve module	M1	M2
ICM	Motor valve module	M1	(2)
ICFD 20	Defrost module	(2)	M2
ICFS	Shut-off valve module	M1	M2
ICFF	Strainer module	(2)	M2
ICM	Motor operated valve module	M1	(2)

**Table 116: ICF 20 and ICF 25 with four modules**

Function Module Type		Can be installed in these locations			
ICFS	Shut-off valve module	M1	M2	M3	M4
ICFR	Manual regulating valve module	M1	M2	M3	M4
ICFF	Strainer module	(2)	M2	(2)	M4
ICFE	Solenoid valve module	(2)	(2)	M3	(2)
ICFC	Check valve module	(2)	(2)	(2)	M4
ICFN	Stop & check valve module	(2)	(2)	(2)	M4
ICM	Motor operated valve module	M1	(2)	M3	(2)
ICFB	Blind top cover	M1	M2	M3	M4
ICFA	Electronic expansion valve module (for ICF 20 only)	M1	(2)	M3	(2)
ICFE20H	Solenoid valve module (for ICF 20 only)	M1	(2)	M3	(2)
ICFO	Manual opening module	(2)	(2)	(2)	M4
ICFW	Welding module	M1	M2	M3	M4
ICFD	Drain module (for ICF 15 and 20 only)	(2)	M2	(2)	M4

**Table 117: ICF 20 and ICF 25 with six modules**

Function Module Type		Can be installed in these locations					
ICFS	Shut-off valve module	M1	M2	M3	M4	M5	M6
ICFR	Manual regulating valve module	M1	M2	M3	M4	M5	M6
ICFF	Strainer module	(2)	M2	(2)	M4	(2)	M6
ICFE	Solenoid valve module	(2)	(2)	M3	(2)	(2)	(2)
ICFC	Check valve module	(2)	(2)	(2)	M4	(2)	M6
ICFN	Stop & check valve module	(2)	(2)	(2)	M4	(2)	M6
ICM	Motor operated valve module	M1	(2)	M3	(2)	M5	(2)
ICFB	Blind top cover	M1	M2	M3	M4	M5	M6
ICFA	Electronic expansion valve module (for ICF 20 only)	M1	(2)	M3	(2)	M5	(2)
ICFE20H	Solenoid valve module (for ICF 20 only)	M1	(2)	M3	(2)	M5	(2)
ICFO	Manual opening module	(2)	(2)	(2)	M4	(2)	(2)
ICFW	Welding module	M1	M2	M3	M4	M5	M6
ICFD	Drain module (for ICF 15 and 20 only)	(2)	M2	(2)	M4	(2)	M6

**Table 118: ICF 50 with four modules**

Function Module Type		Can be installed in these locations			
SVA-S	Shut-off valve module	(SVA-S 50) <sup>(1)</sup>	(2)	(2)	M4
ICFB	Blind top cover	(SVA-S 50) <sup>(1)</sup>	M2	(2)	(2)
FIA	Strainer module	(SVA-S 50) <sup>(1)</sup>	M2	(2)	(2)
ICS	Pilot-operated valve module	(SVA-S 50) <sup>(1)</sup>	(2)	M3	(2)
ICM	Motor operated valve module	(SVA-S 50) <sup>(1)</sup>	(2)	M3	(2)
ICLX	2-step solenoid valve module	(SVA-S 50) <sup>(1)</sup>	(2)	M3	(2)
REG-SB	Manual regulating valve module	(SVA-S 50) <sup>(1)</sup>	(2)	(2)	M4

**Table 119: ICF 65 with three modules**

Function Module Type		Can be installed in these locations			
SVA-S	Shut-off valve module	(SVA-S 65) <sup>(1)</sup>	(2)	(2)	M4
ICFB	Blind top cover	(SVA-S 65) <sup>(1)</sup>	(2)	(2)	(2)
FIA	Strainer module	(SVA-S 65) <sup>(1)</sup>	(2)	(2)	(2)
ICS	Pilot-operated valve module	(SVA-S 65) <sup>(1)</sup>	(2)	M3	(2)
ICM	Motor operated valve module	(SVA-S 65) <sup>(1)</sup>	(2)	M3	(2)
ICLX	2-step solenoid valve module	(SVA-S 65) <sup>(1)</sup>	(2)	M3	(2)
REG-SB	Manual regulating valve module	(SVA-S 65) <sup>(1)</sup>	(2)	(2)	M4

<sup>(1)</sup> Module is fixed

<sup>(2)</sup> location not possible



## Certificates, declarations, and approvals

The list contains all certificates, declarations, and approvals for this product type. Individual code number may have some or all of these approvals, and certain local approvals may not appear on the list.

Some approvals may change over time. You can check the most current status at danfoss.com or contact your local Danfoss representative if you have any questions.

The ICF concept is designed to fulfil global refrigeration requirements. For specific approval information, please contact Danfoss.

**Table 120: Compliance**

ICF valve station		
Nominal bore	DN ≤ 25 (1 in.)	DN 32-65 (1 ¼ - 2 ½")
Classified for	Fluid group I	
Category	Article 4, paragraph 3	II

**Table 121: Conformity Approvals**

	UL approved
---	-------------

**Table 122: Approvals**

File name	Document type	Document topic	Approval authority
EAC RU Д-ДК.БЛ08.В.03759	EAC Declaration	EMC	EAC - Eurasian Customs Union
EAC RU Д-ДК.РА01.В.72054_20	EAC Declaration	PED	EAC - Eurasian Customs Union
RMRS 19.10325.266	Marine - Safety Certificate	-	RMRS - Russian Maritime Register o
Danfoss EU 033F0685.AK	EU Declaration	EMC/PED	Danfoss
Danfoss MD 033F0474.AC	Manufacturer's Declaration	ATEX	Danfoss
TSSA CRN.0C19908.5123467890YTN	-	CRN	TSSA - Technical Standards & Safety Authority
TÜV 0045-202-1204/Z-00354-19-D-002(03)	Pressure - Safety Certificate	PED	TÜV

## Online support

Danfoss offers a wide range of support along with our products, including digital product information, software, mobile apps, and expert guidance. See the possibilities below.

### The Danfoss Product Store



The Danfoss Product Store is your one-stop shop for everything product related—no matter where you are in the world or what area of the cooling industry you work in. Get quick access to essential information like product specs, code numbers, technical documentation, certifications, accessories, and more.

Start browsing at [store.danfoss.com](https://store.danfoss.com).

### Find technical documentation



Find the technical documentation you need to get your project up and running. Get direct access to our official collection of data sheets, certificates and declarations, manuals and guides, 3D models and drawings, case stories, brochures, and much more.

Start searching now at [www.danfoss.com/en/service-and-support/documentation](https://www.danfoss.com/en/service-and-support/documentation).

### Danfoss Learning



Danfoss Learning is a free online learning platform. It features courses and materials specifically designed to help engineers, installers, service technicians, and wholesalers better understand the products, applications, industry topics, and trends that will help you do your job better.

Create your Danfoss Learning account for free at [www.danfoss.com/en/service-and-support/learning](https://www.danfoss.com/en/service-and-support/learning).

### Get local information and support



Local Danfoss websites are the main sources for help and information about our company and products. Find product availability, get the latest regional news, or connect with a nearby expert—all in your own language.

Find your local Danfoss website here: [www.danfoss.com/en/choose-region](https://www.danfoss.com/en/choose-region).

### Spare Parts



Get access to the Danfoss spare parts and service kit catalog right from your smartphone. The app contains a wide range of components for air conditioning and refrigeration applications, such as valves, strainers, pressure switches, and sensors.

Download the Spare Parts app for free at [www.danfoss.com/en/service-and-support/downloads](https://www.danfoss.com/en/service-and-support/downloads).

### Coolselector®2 - find the best components for you HVAC/R system



Coolselector®2 makes it easy for engineers, consultants, and designers to find and order the best components for refrigeration and air conditioning systems. Run calculations based on your operating conditions and then choose the best setup for your system design.

Download Coolselector®2 for free at [coolselector.danfoss.com](https://coolselector.danfoss.com).

Any information, including, but not limited to information on selection of product, its application or use, product design, weight, dimensions, capacity or any other technical data in product manuals, catalogues descriptions, advertisements, etc. and whether made available in writing, orally, electronically, online or via download, shall be considered informative, and is only binding if and to the extent, explicit reference is made in a quotation or order confirmation. Danfoss cannot accept any responsibility for possible errors in catalogues, brochures, videos and other material. Danfoss reserves the right to alter its products without notice. This also applies to products ordered but not delivered provided that such alterations can be made without changes to form, fit or function of the product. All trademarks in this material are property of Danfoss A/S or Danfoss group companies. Danfoss and the Danfoss logo are trademarks of Danfoss A/S. All rights reserved.